

HERZ STRÖMAX 4017M

Fixed Orifice Commissioning Valve

Data sheet for 4017 0x, Issue 0223

☑ Dimensions

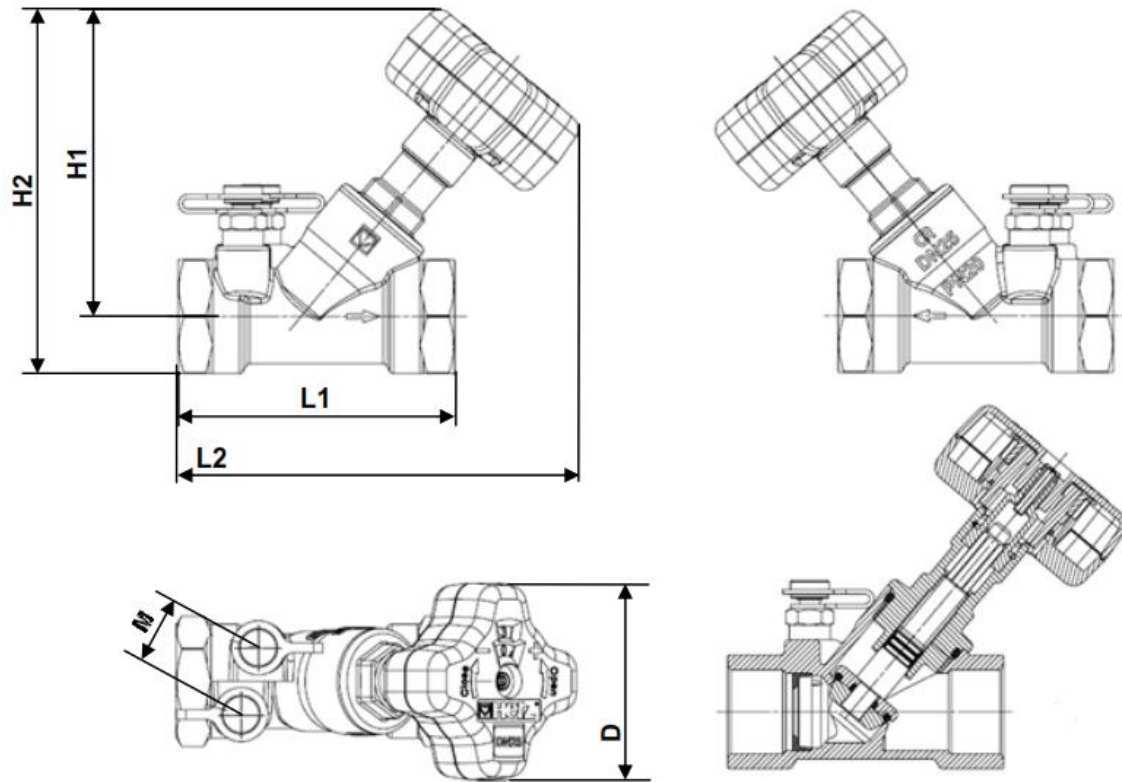

Order Nr.	DN	L1 [mm]	L2 [mm]	H1 [mm]	H2 [mm]	M [mm]	D [mm]	Kv Valve	Kvs Orifice
1 4017 11	15 LF	83	129	96	109	25	70	0.46	0.48
1 4017 21	15 MF	83	129	96	109	25	70	0.88	0.97
1 4017 01	15	83	129	96	109	25	70	2.00	1.95
1 4017 02	20	91	135	99	115	25	70	3.60	3.95
1 4017 03	25	110	146	109	130	25	70	6.50	7.90
1 4017 04	32	122	159	117	142	25	70	13.30	15.75
1 4017 05	40	135	178	136	163	25	70	18.50	21.50
1 4017 06	50	164	197	140	175	25	70	33.00	46.70

☑ Material and construction

Body:	DZR brass CW602N
Stem & disk:	DZR brass CW602N
Fixed orifice:	DZR brass CW602N
Seals:	EPDM
Test points:	DZR brass CW602N / EPDM

☑ Operating data

Max. operating pressure:	20 bar at 20°C
Min. operating temperature:	-20°C
Max. operating temperature:	130°C at 10 bar

Manufactured to BS7350

Medium:

Heating water quality according to ÖNORM H5195 or VDI-Standard 2035. The use of ethylene or propylene glycol in a mixing ratio 25- 50% is allowed. Please refer to manufacturers documentation when using ethylene glycol products for frost and corrosion protection. HERZ FODRV for heating and chilled water is not suitable for use with aggressive medium (such as: acids, alkalis, combustible and explosive gases) because it can destroy sealing components.

Pursuant to Article 33 of the REACH Regulation (EC No. 1907/2006), we are obliged to point out that the material lead is listed on the SVHC list and that all brass components manufactured in our products exceed 0.1% (w / w) lead (CAS: 7439-92-1 / EINECS: 231-100-4). Since lead is a component part of an alloy, actual exposure is not possible and therefore no additional information on safe use is necessary.

☑ Valve Application

The valve is designed to measure and regulate flowrate to aid the balancing and commissioning of a system water flowrates. The valve has an integral fixed orifice for measuring the differential pressure, to ascertain the flowrate by calculation or with reference to the valve flowcharts. The differential pressure is measured through two test points mounted on either side of the fixed orifice.

☑ Valve Installation

The valve can be installed in any orientation observing the flow direction arrow on the body.

CIBSE Commissioning code W: 2010 states that Fixed orifice double regulating valves must always be installed with a minimum of 5 pipe diameters of straight pipe, without intrusion, upstream of the orifice plate. Downstream of the valve a minimum of 2 pipe diameters of straight pipe are required.

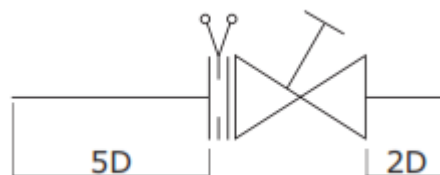

☑ Valve setting

The hand wheel position is indicated in the digital display readout on the top of the hand wheel, the valve set position can be locked easily by means of a concealed memory stop. The valve can be isolated and returned to the preset position at any time. The pre-setting is obscured by the hand wheel and protected against unauthorised operation.

1. Set to the desired step observing the digital display on the hand wheel.
2. Remove the hand wheel locking screw, do not remove the hand wheel from the valve.
3. Screw the pre-setting spindle, which is now accessible, in up to the stop.
4. Screw in the hand wheel locking screw again.
5. Mark the step set at the pre-setting marker and attach the marker to the valve (this step is not essential for the function of the valve but is recommended).

☑ Accessories

Presetting Marker

The pre-setting marker (1 6517 05) is fastened as a tag above the valve or pipe. The setting of the respective valve is marked by cutting or breaking off the teeth at the figures for full and partial turns. This permits checking and/or restoration of the original pre-setting made on the occasion of the system set-up after servicing without having to rely on documentation.

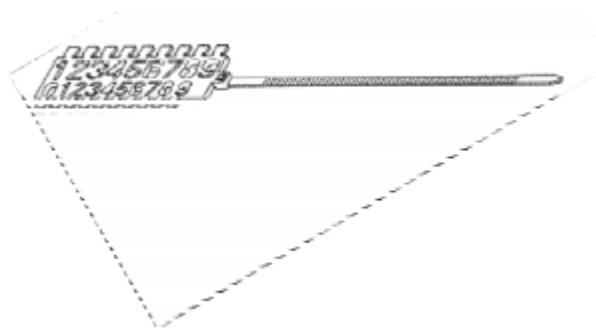

☑ Disposal instruction

The disposal of HERZ Pressfit FODRVs must not endanger the health or the environment. National legal regulations for proper disposal of the HERZ Pressfit FODRVs have to be followed.

HERZ standard diagram	Commissioning Valve
Order Nr.: 1 4017 11	Dim. DN 15 LF

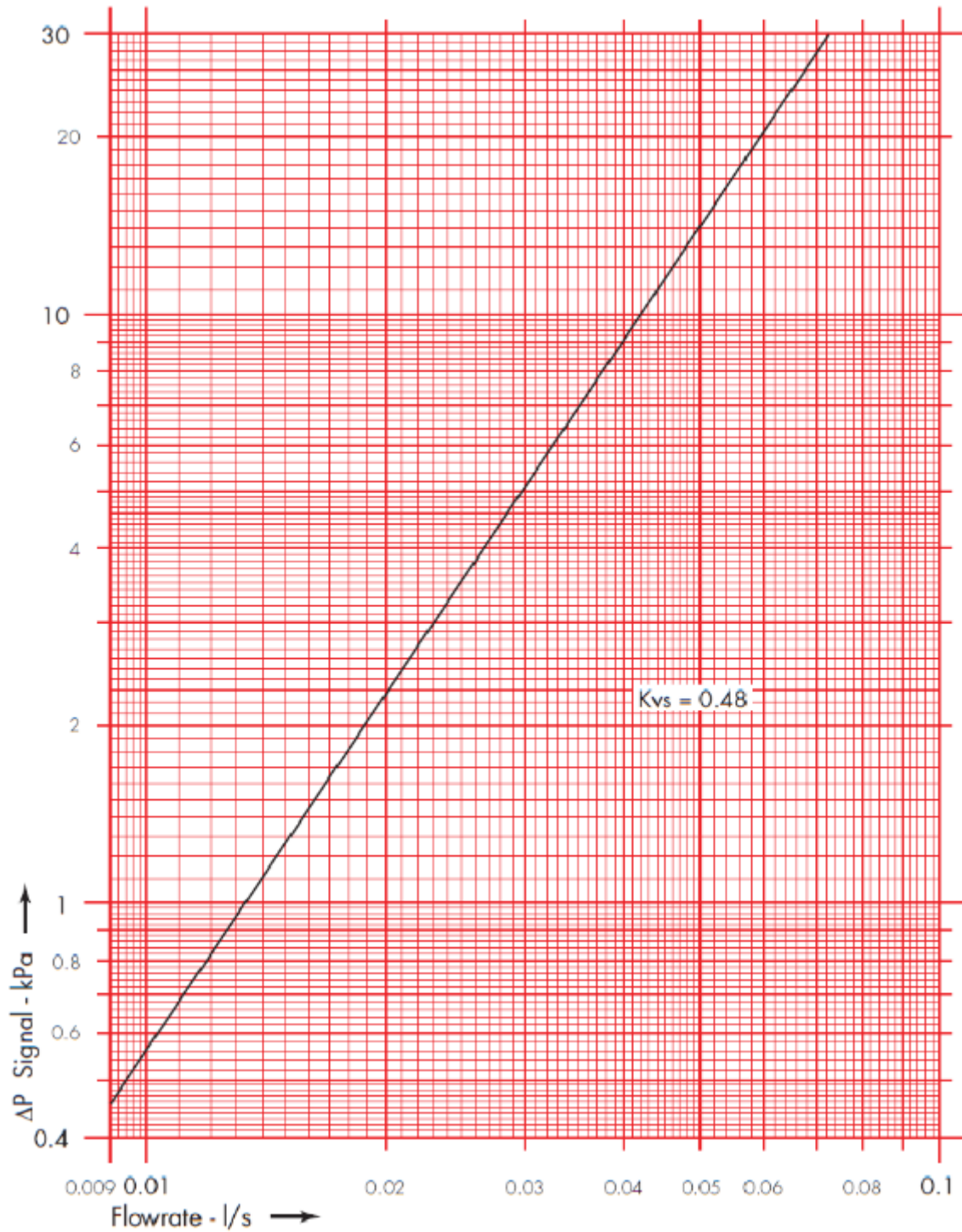

Herz reserve the right to make design modifications

HERZ standard diagram	Commissioning Valve
Order Nr.: 1 4017 11	Dim. DN 15 LF

Position	1	1.5	2	2.5	3	3.5	4
Kv	0.07	0.14	0.22	0.29	0.35	0.41	0.46

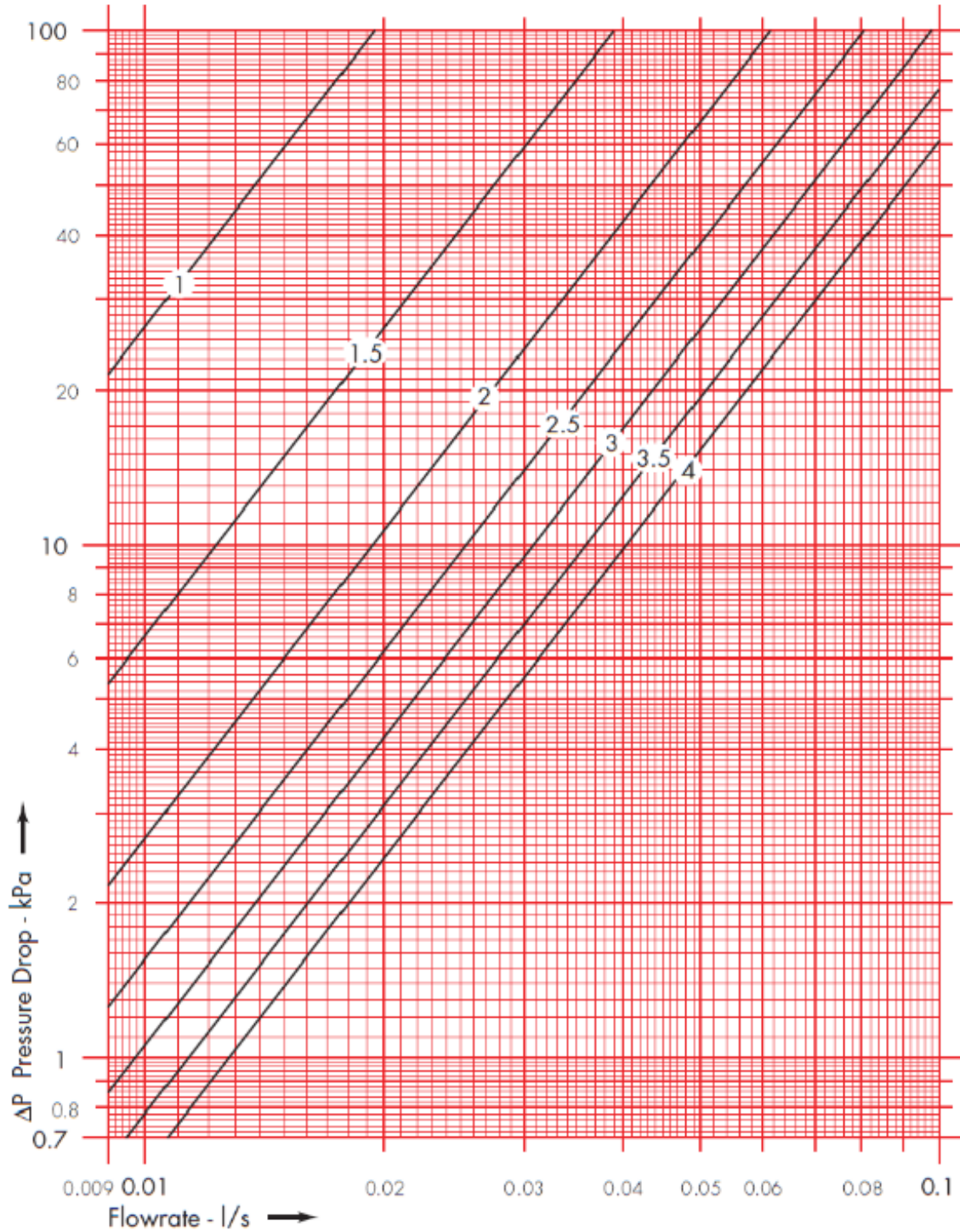

Herz reserve the right to make design modifications

HERZ standard diagram	Commissioning Valve
Order Nr.: 1 4017 21	Dim. DN 15 MF

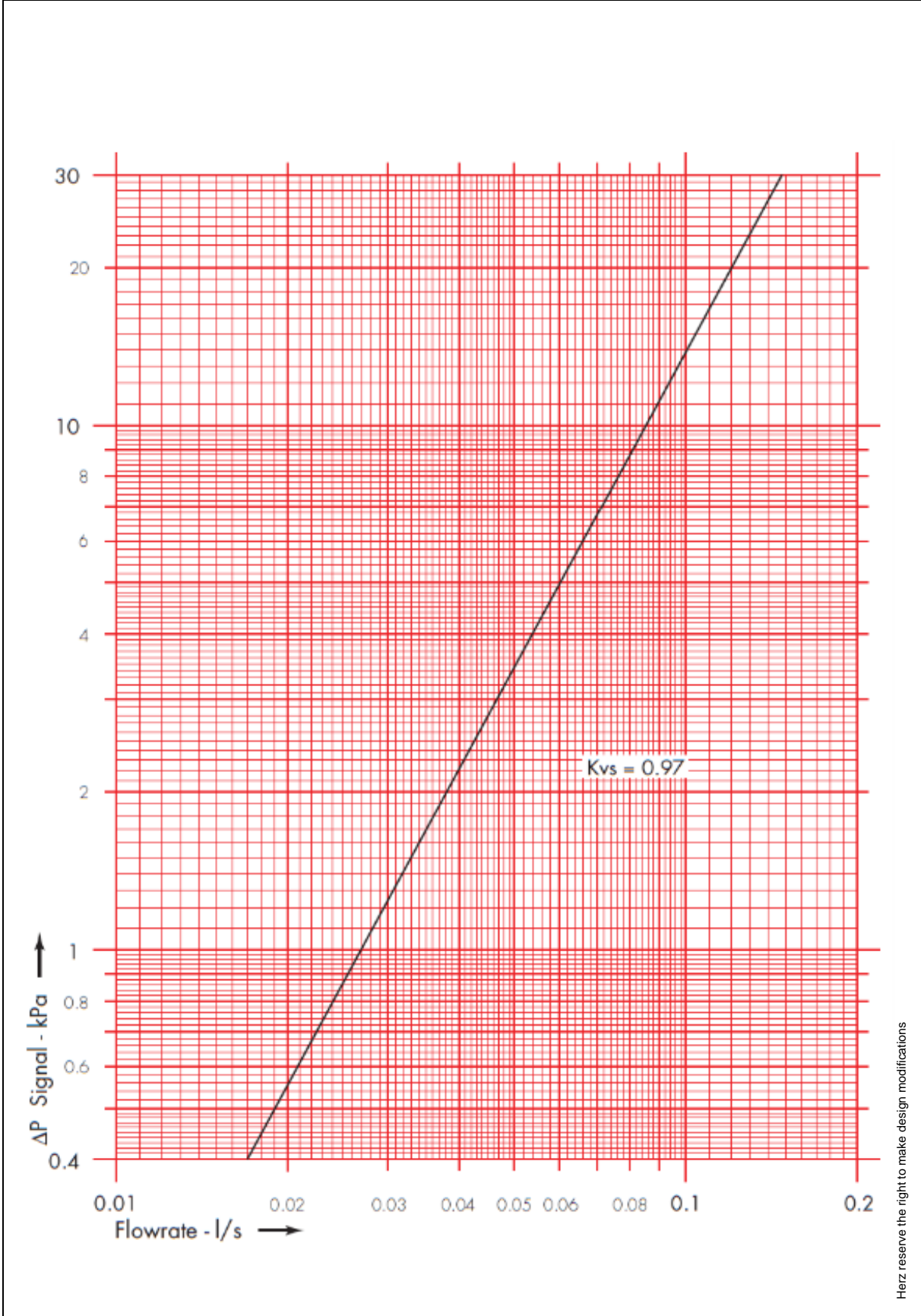

Herz reserve the right to make design modifications

HERZ standard diagram	Commissioning Valve
Order Nr.: 1 4017 21	Dim. DN 15 MF

Position	1	1.5	2	2.5	3	3.5	4
Kv	0.30	0.42	0.53	0.66	0.78	0.86	0.88

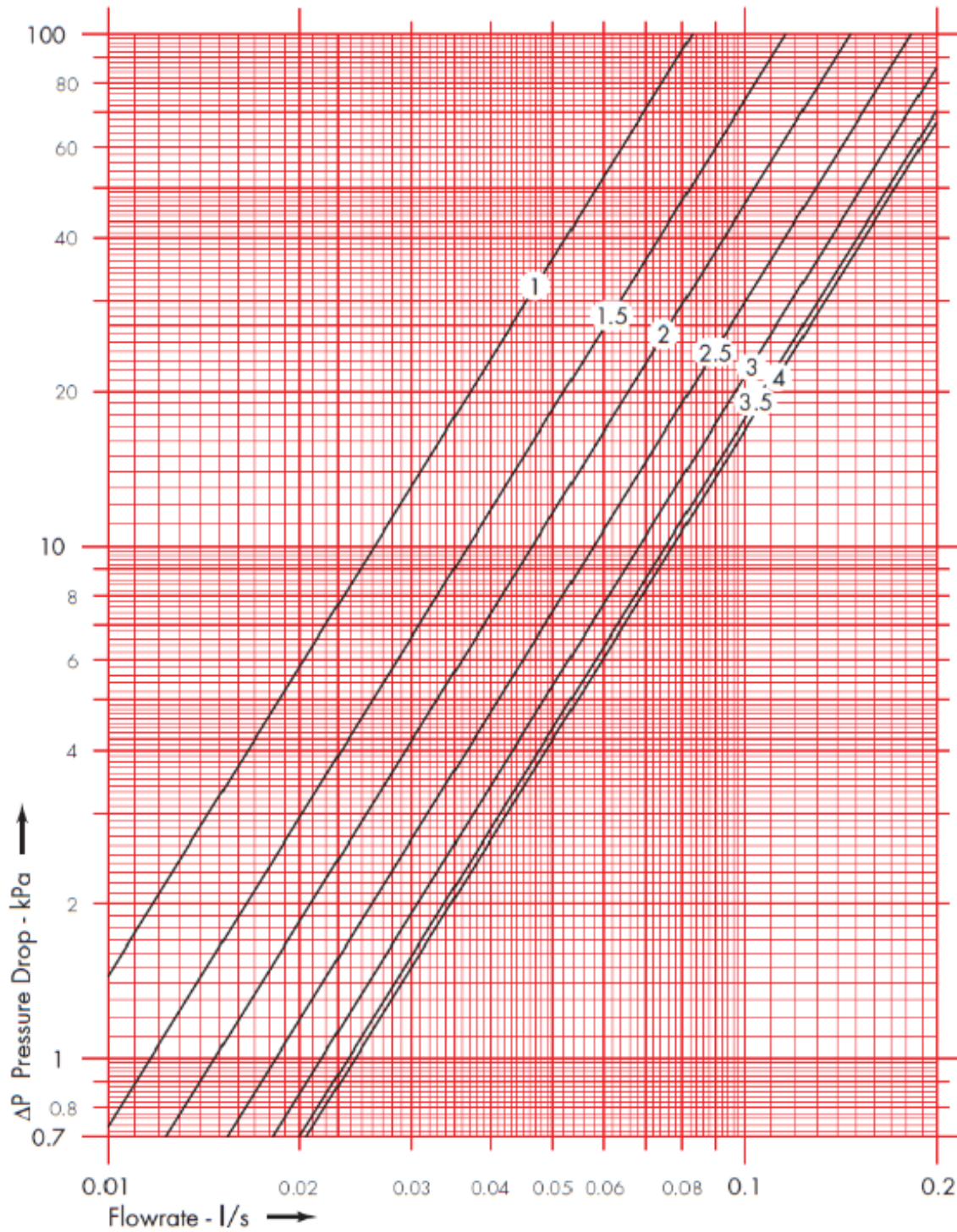

Herz reserve the right to make design modifications

HERZ standard diagram	Commissioning Valve
Order Nr.: 1 4017 01	Dim. DN 15

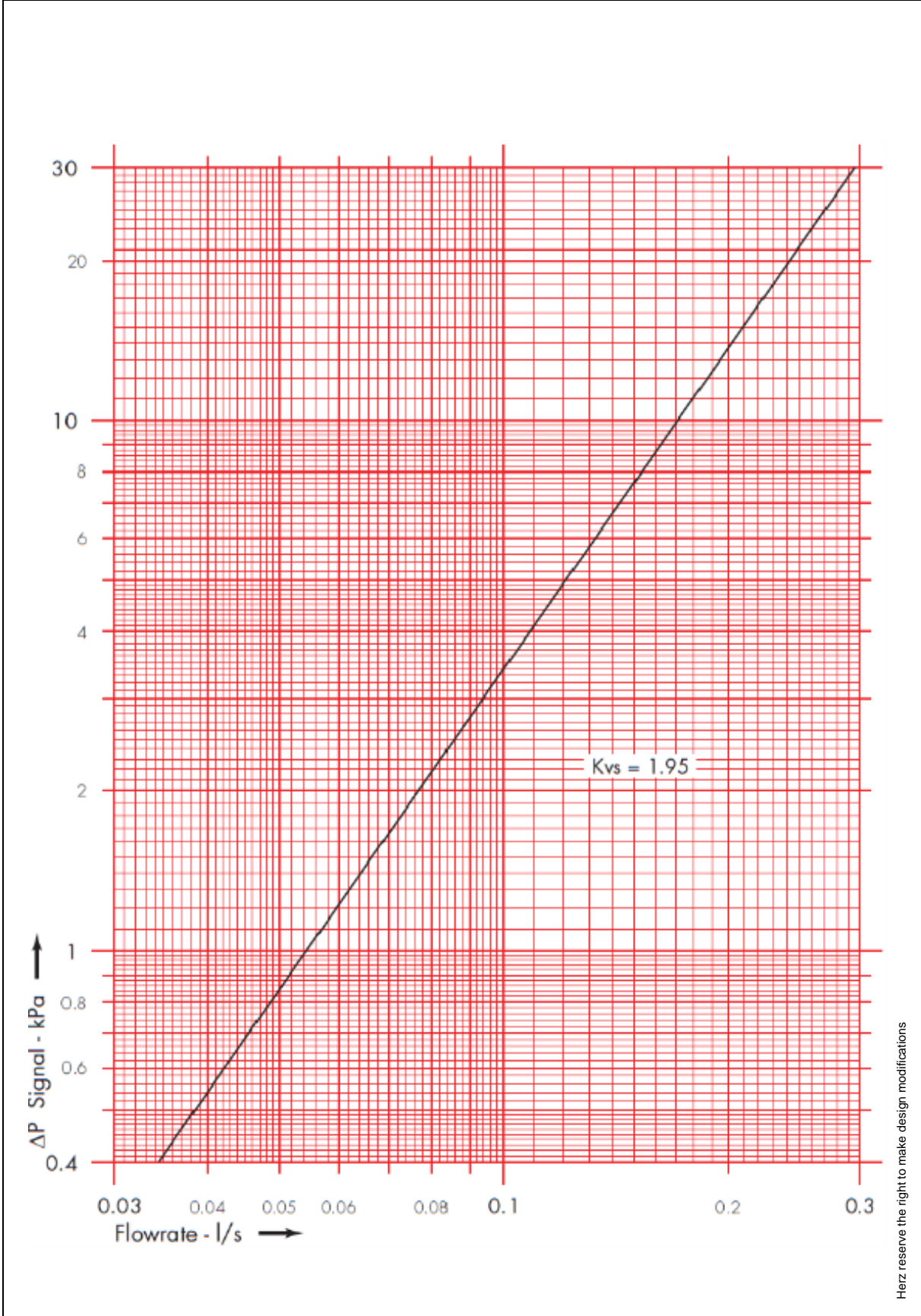

HERZ standard diagram	Commissioning Valve
Order Nr.: 1 4017 01	Dim. DN 15

Position	1	1.5	2	2.5	3	3.5	4
Kv	0.60	0.81	1.0	1.2	1.42	1.8	2.0

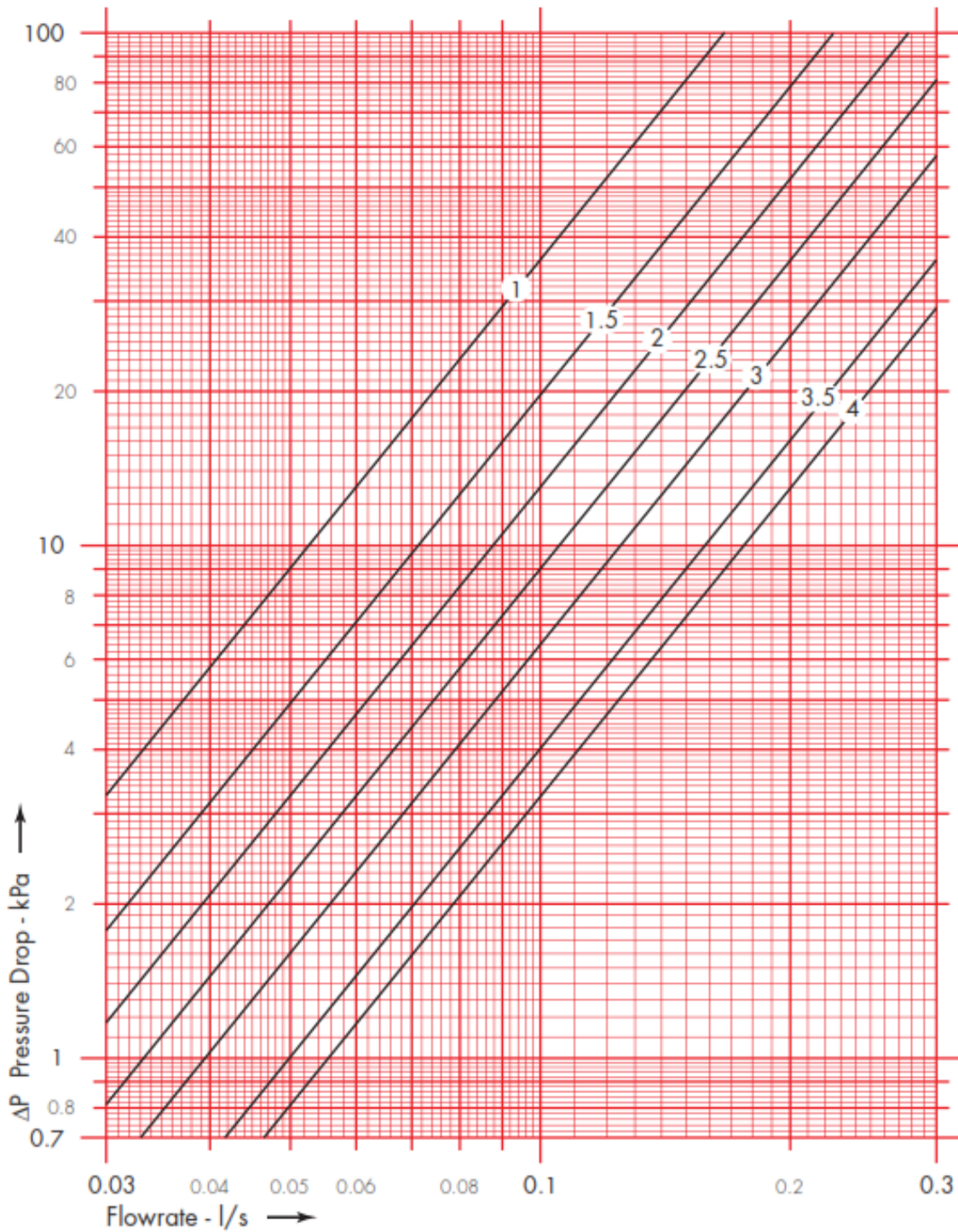

Herz reserve the right to make design modifications

HERZ standard diagram	Commissioning Valve
Order Nr.: 1 4017 02	Dim. DN 20

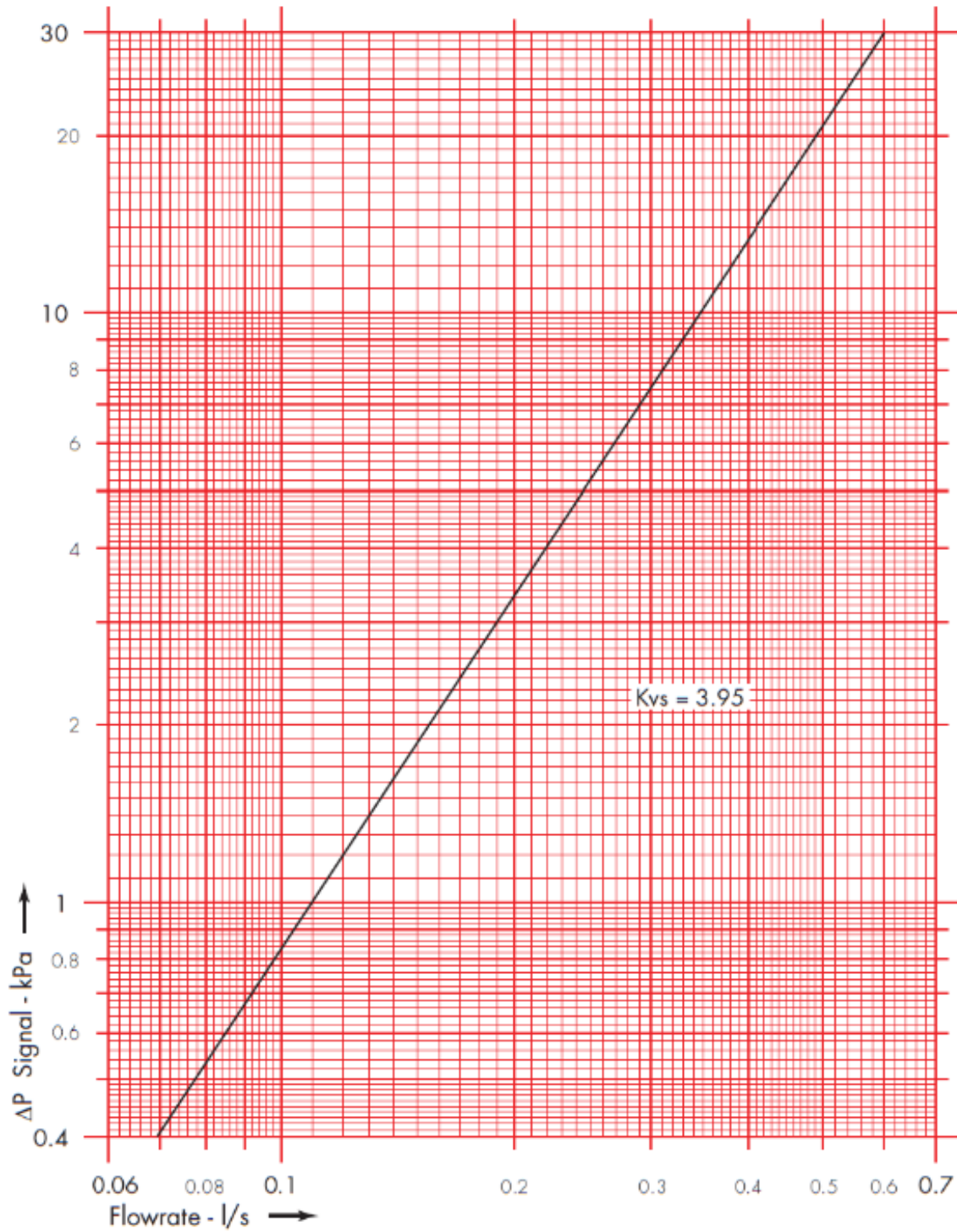

Herz reserve the right to make design modifications

HERZ standard diagram	Commissioning Valve
Order Nr.: 1 4017 02	Dim. DN 20

Position	1	1.5	2	2.5	3	3.5	4
Kv	0.63	1.2	1.7	2.25	2.8	3.25	3.6

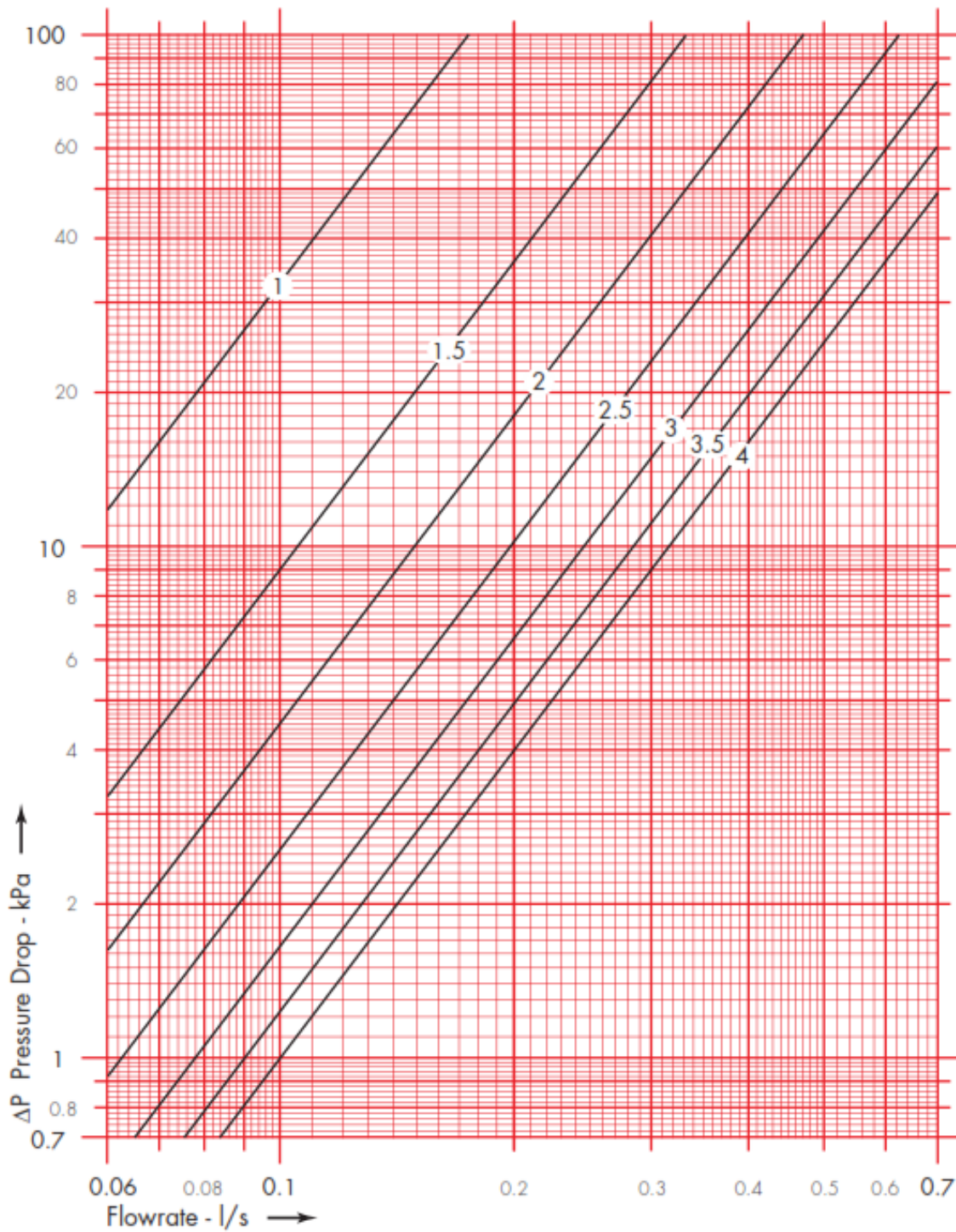

Herz reserve the right to make design modifications

HERZ standard diagram	Commissioning Valve
Order Nr.: 1 4017 03	Dim. DN 25

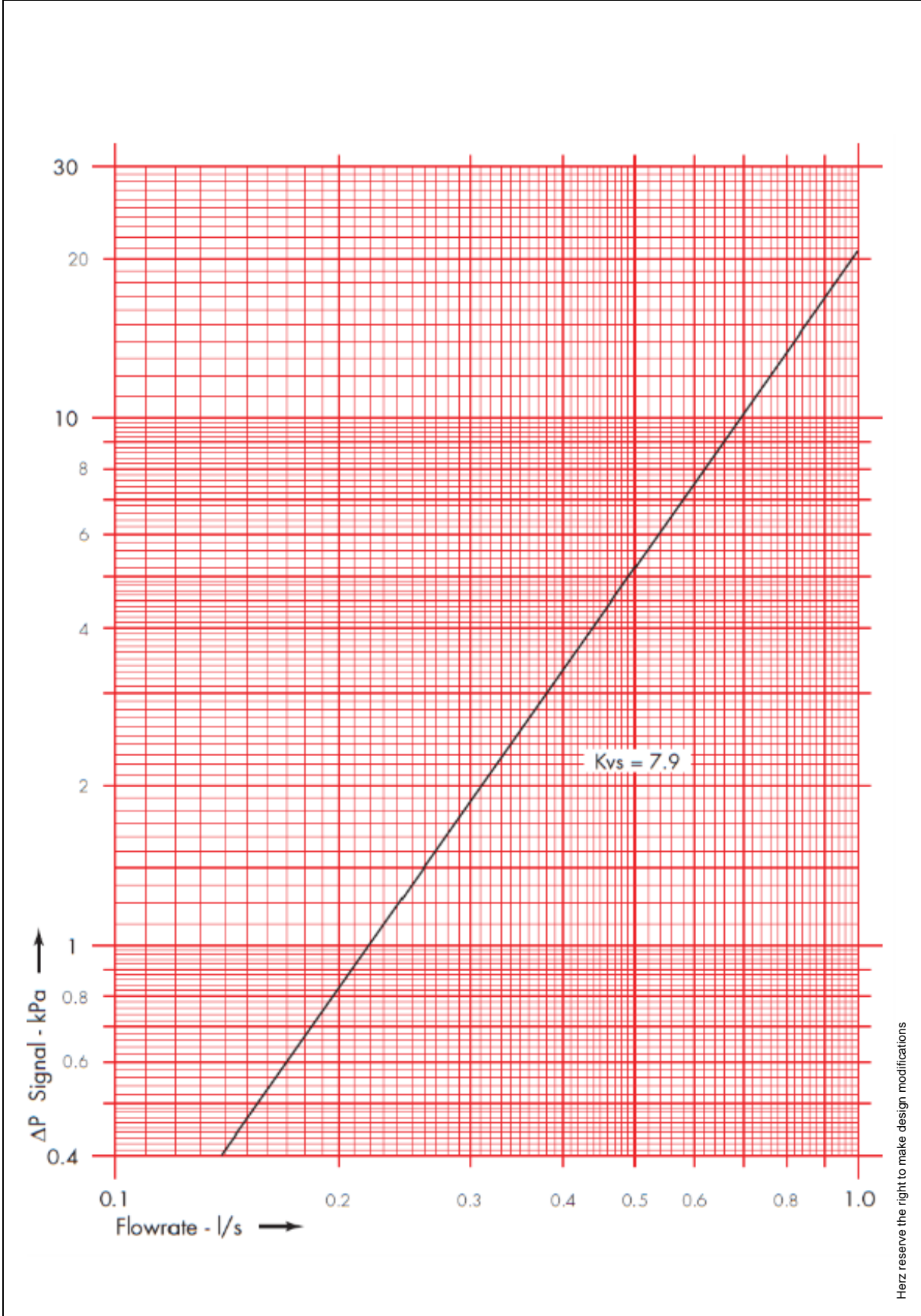

HERZ standard diagram	Commissioning Valve
Order Nr.: 1 4017 03	Dim. DN 25

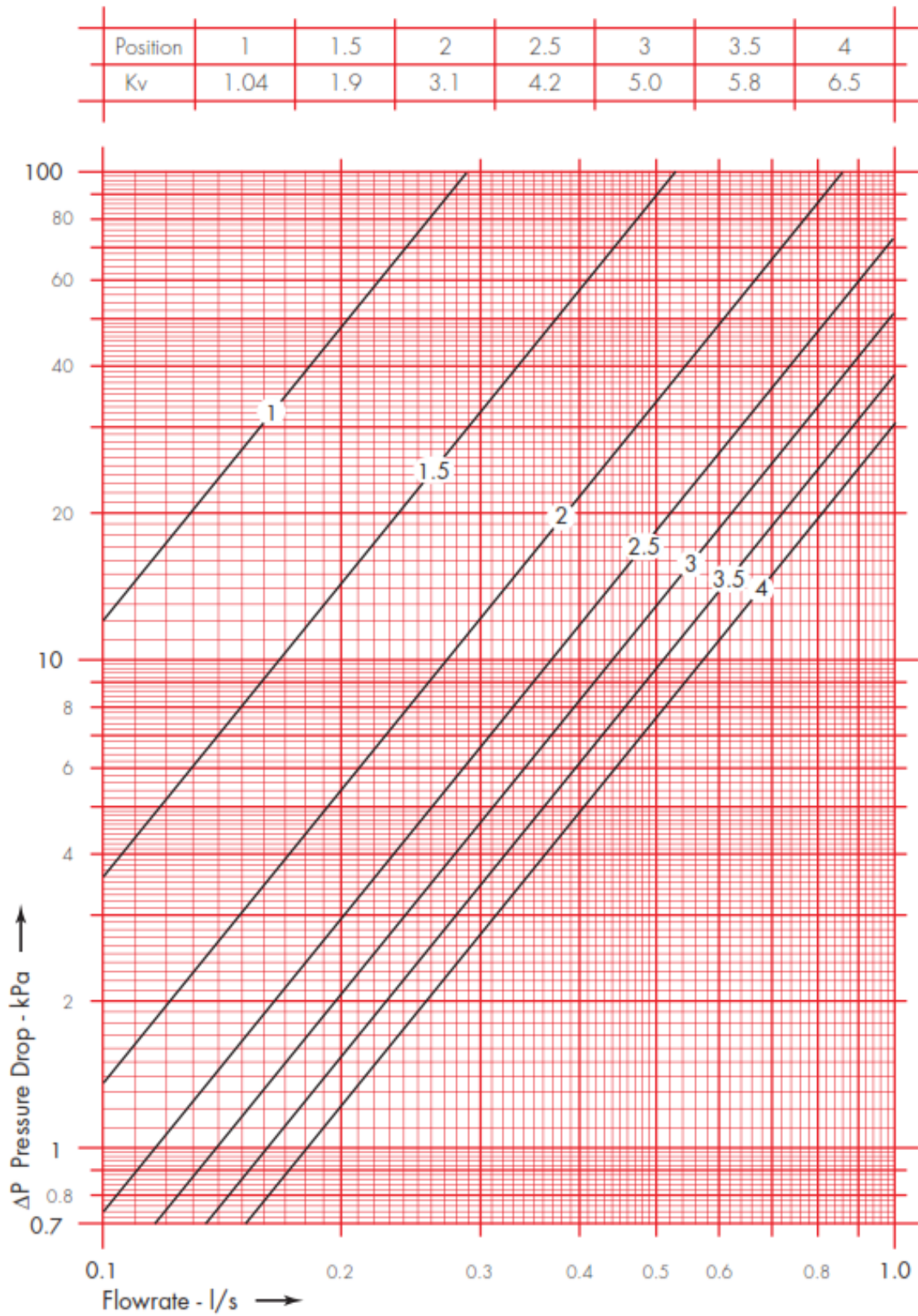

HERZ feuchte und feuchte Räume, feuchte Räume

HERZ standard diagram	Commissioning Valve
Order Nr.: 1 4017 04	Dim. DN 32

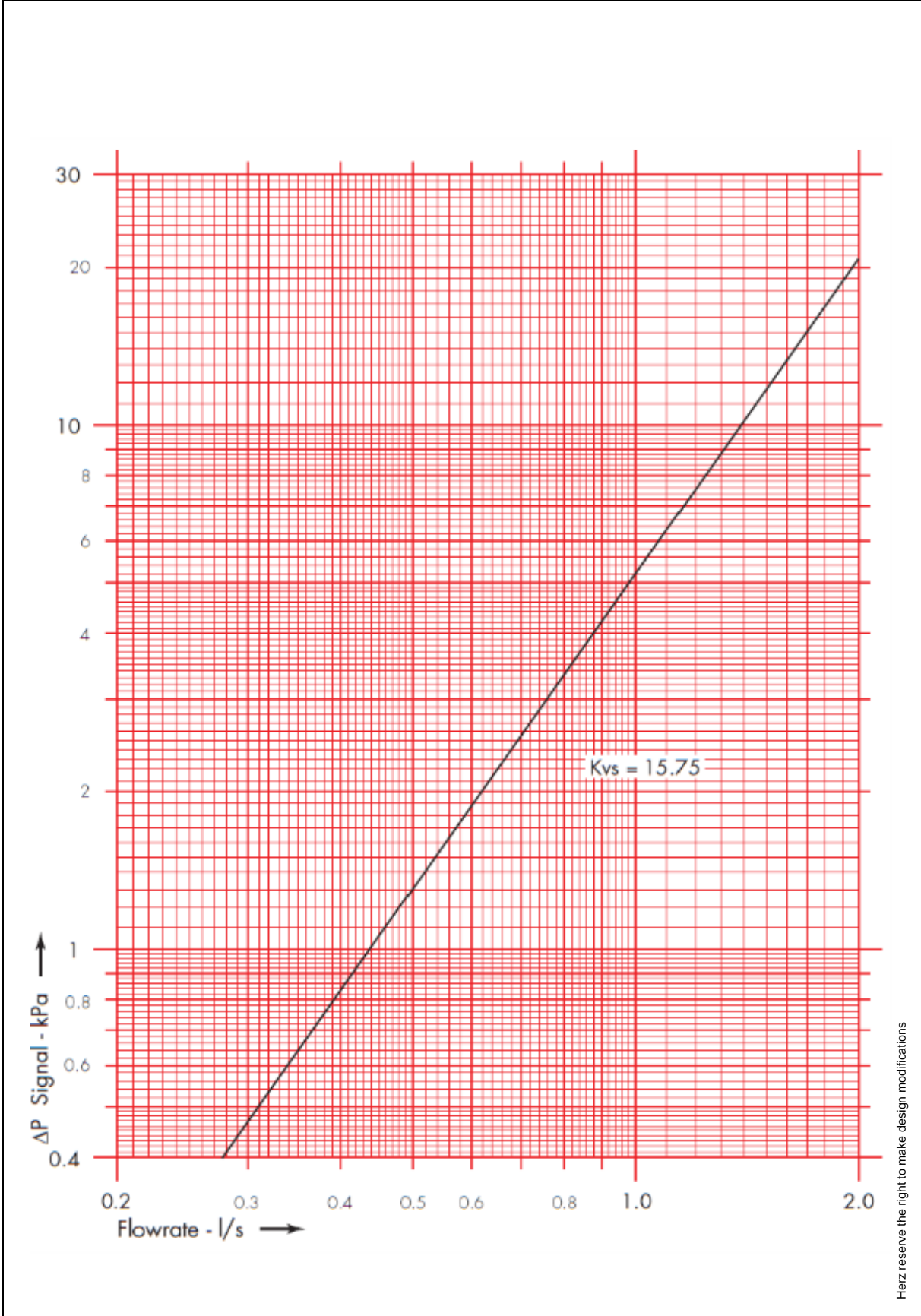

Herz reserve the right to make design modifications

HERZ standard diagram	Commissioning Valve
Order Nr.: 1 4017 04	Dim. DN 32

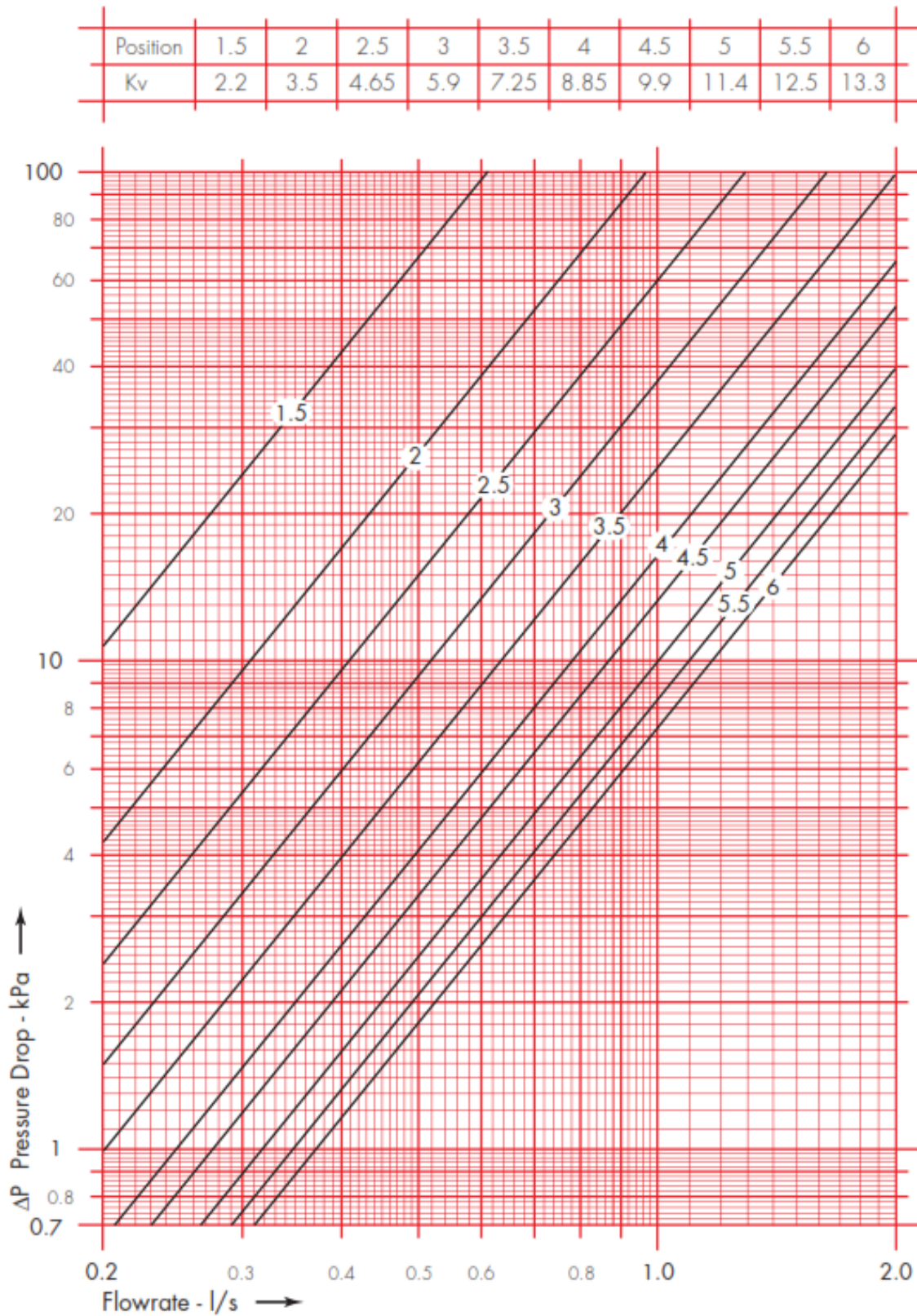

HERZ Techn. Zeichnung

HERZ standard diagram	Commissioning Valve
Order Nr.: 1 4017 05	Dim. DN 40

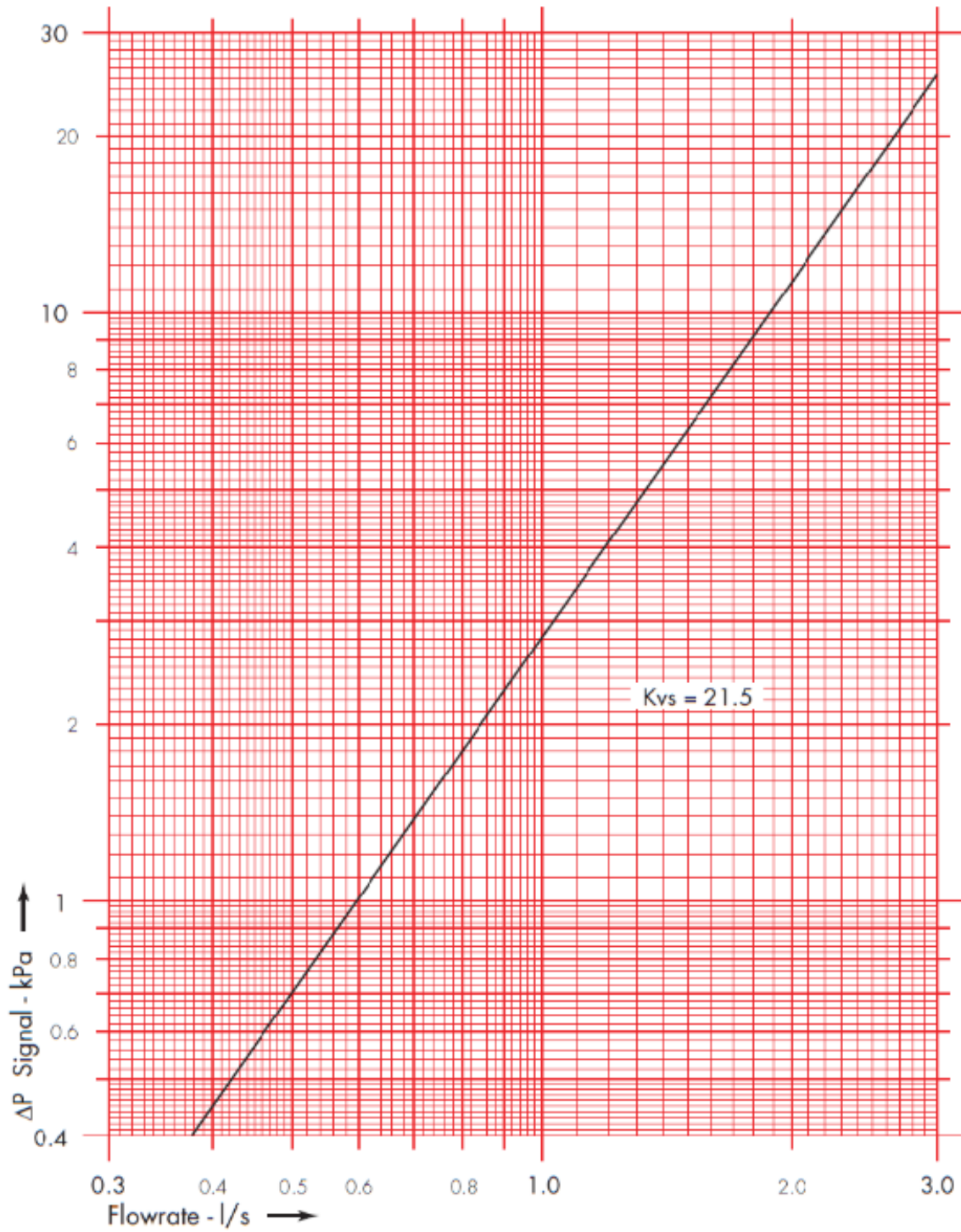

Herz reserve the right to make design modifications

HERZ standard diagram	Commissioning Valve
Order Nr.: 1 4017 05	Dim. DN 40

Position	1.5	2	2.5	3	3.5	4	4.5	5	5.5	6
Kv	4.8	6.3	7.9	9.5	11.2	13.0	14.7	16.3	17.4	18.5

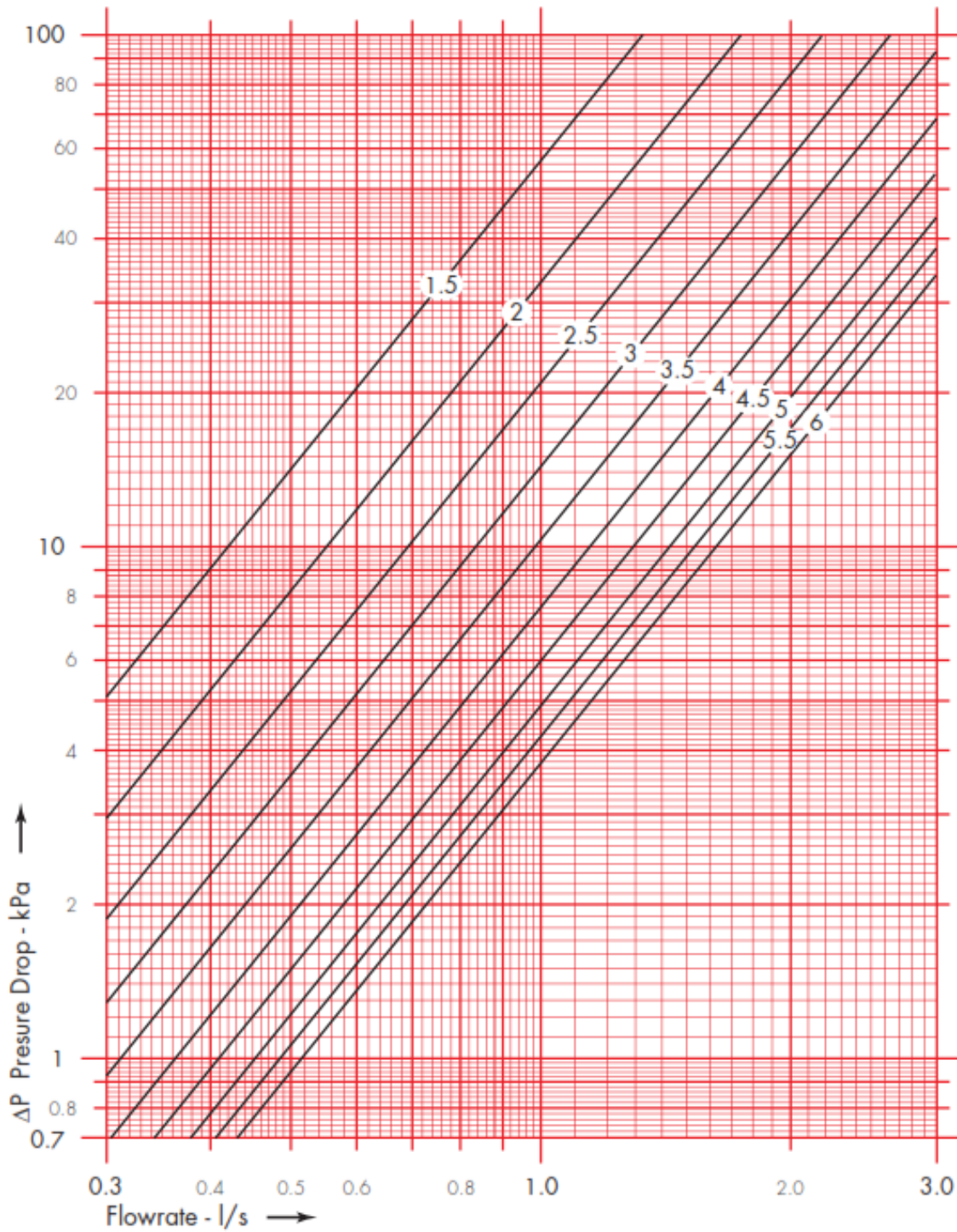

Herz, Industrie- und Ingentechnik GmbH, Memmingen

HERZ standard diagram	Commissioning Valve
Order Nr.: 1 4017 06	Dim. DN 50

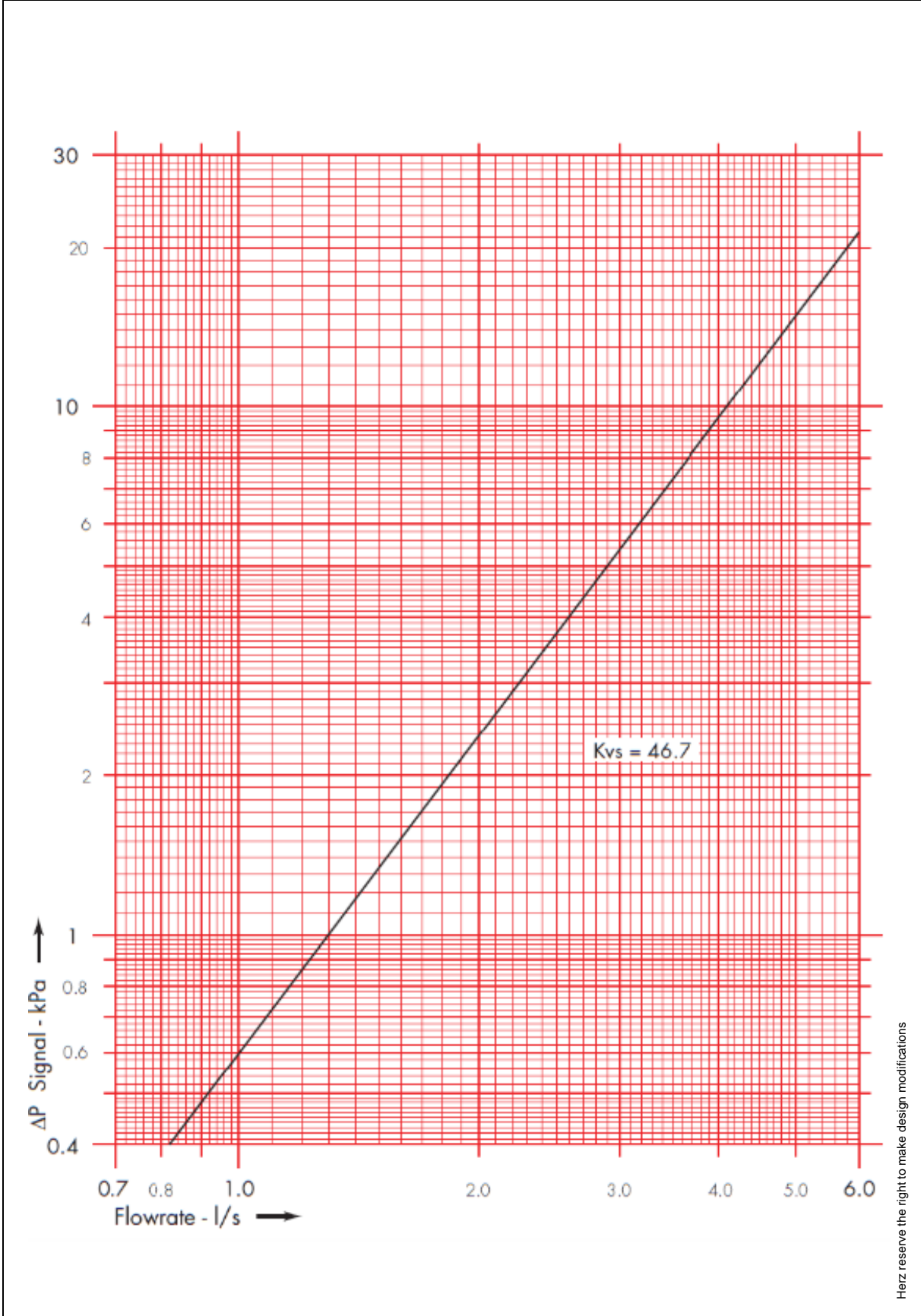

HERZ standard diagram	Commissioning Valve
Order Nr.: 1 4017 06	Dim. DN 50

Position	2	3	4	5	6	7	8
Kv	8.7	13.0	18.0	22.5	26.7	30.3	33.0

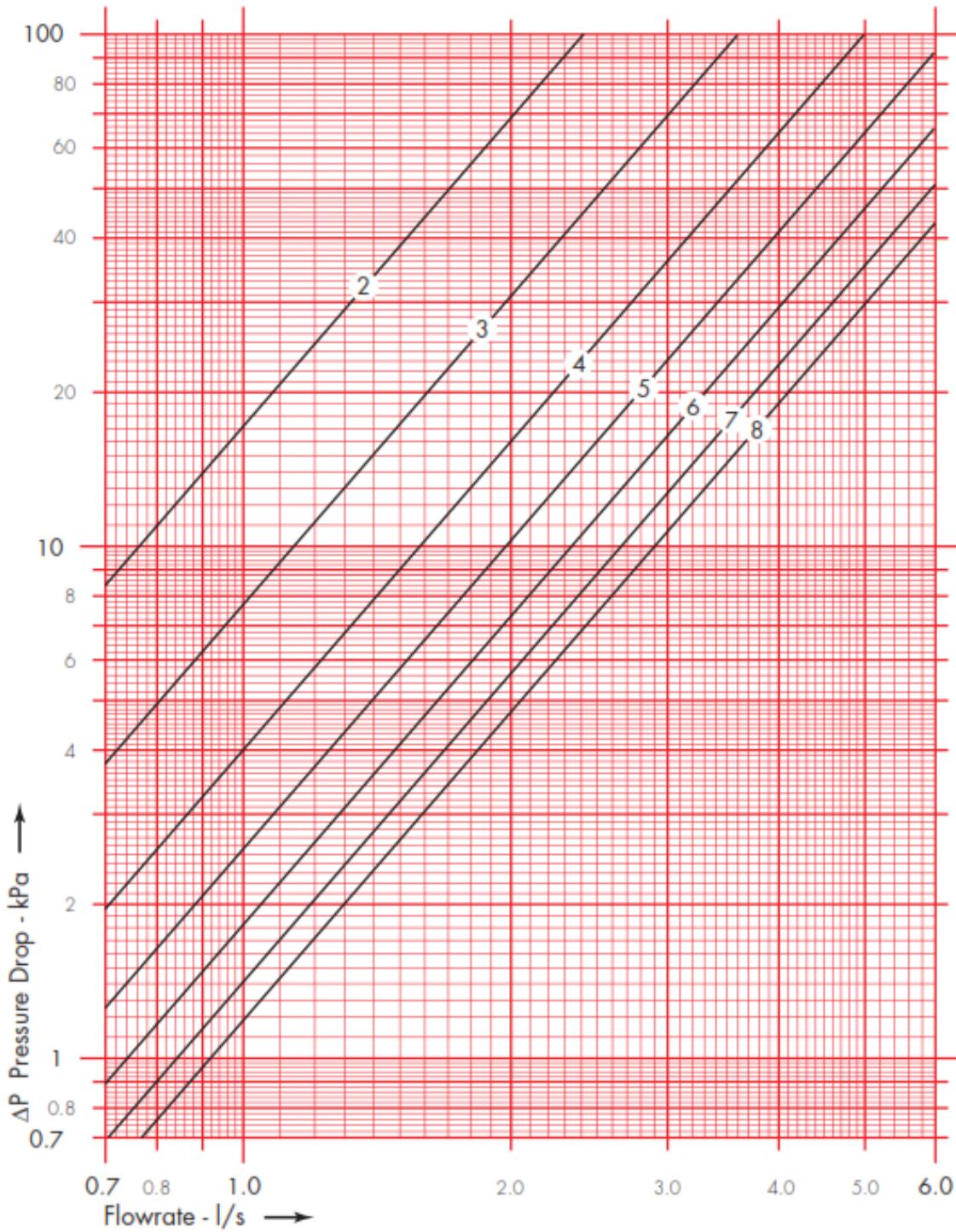

Herz reserve the right to make design modifications

