

USER MANUAL

HERZ Valves UK

Progress House, Moorfield Point
Moorfield Road, Slyfield Industrial Estate
Guildford, Surrey GU1 1RU
Tel.: 01483 502211, Fax: 01483 502025
E-Mail: sales@herzvalves.com

HERZ Armaturen GmbH

Richard-Strauss-Str. 22, A - 1230 Vienna
Tel.: +43 (0)1 616 26 31-0, Fax: +43 (0)1 616 26 31-27
E-Mail: office@herz.eu

www.herz.eu

Introduction

The HERZ HIU Manchester is a wall mounted unit for providing hot water. In contrast to a hot water boiler which heats and then stores the water before it is being used, the unit operates only when hot water is required.

Due to inner system division incorporating two heat exchangers, domestic hot water and heating is supplied completely separately. The HERZ HIU Manchester ensures constant temperature and flow of hot water, no matter how much or how often water is drawn from a tap.

Advantages of the HERZ HIU:

- enables individual room heating and supply of domestic hot water
- System separation with two heat exchangers
- the continuous-flow heating enables a permanent supply when domestic hot water is required
- the HERZ HIU can be customized to the individual requirements of the consumer
- minimal space required
- needs no domestic hot water boiler
- the constant water temperature in the heat exchanger reduces the danger of legionella- and lime formation
- low return temperature
- minimal heat losses in the system
- easy to install
- optimal heating comfort

1. Function

In the stand-by mode the heating water flows from the primary circuit (district heating main) via a bypass which is kept at operating temperature with a return temperature limiter. If hot water is drawn from a tap by a domestic user connected to the system, the control valve for the cold and heating water is opened by the difference in pressure. Cold water flows through the heat exchanger, is heated up and promptly available as hot water at the domestic hot water tap. The temperature of the domestic hot water is controlled by a thermostat. Using an immersion sensor, this thermostat controls the temperature of the hot water that exits the heat exchanger, which in turn regulates the pressure and temperature controller. If there is no demand from the hot water taps, the primary heating water flows in to the second heat exchanger and is used for the heating circuit

An integrated circulation pump is installed in the heating flow, to

ensure constant circulation in the heating circuit and an expansion vessel holds the pressure constant in the system. A Pressure Relief safety valve is installed into the return, It opens automatically if the pressure in the system is too high. A zone valve with an actuating drive is installed into the return of the HIU to shut off the heating circuit, when not required.

A thermostatic bypass valve fitted with a return temperature limiter is installed into the return of the HIU Manchester to regulate the return temperature. Strainers with a fine-mesh screen of 0.5 mm are fitted in the primary heating flow and secondary heating return to catch impurities.

2. General notes on installation

1. For installation please refer to the drawings and manual included in the packaging.
2. When choosing where to mount the HERZ HIU, the weight of the unit itself as well as the weight of the water must be taken into account.
3. If the HERZ HIU is built in or installed in confined spaces, intermediate ceilings, etc., the front of the unit must be freely accessible for repair and maintenance purposes.
4. Before mounting the HERZ HIU, check that the wall is vertical.
5. Depending on the type of wall where the unit is mounted, the appropriate wall anchors and screws must be used.

3. Safety notes

1. The unit must be installed and connected by professional plumbing and heating engineers only.
2. Only use original HERZ spare parts to replace faulty parts or heating components.
3. Check all connections for leakages prior to starting up the heating system.
4. All screws must be checked and tightened after the unit has been installed.
5. The user must not make any technical changes to the heating system. Otherwise HERZ will not assume liability for any resulting damage.
6. The HERZ HIU must only be installed in rooms and locations that meet the legal requirements.

4. Equipment

Important components of the HERZ HIU Manchester

PT-controller

As the central control valve in the HERZ HIU the HERZ PT-controller ensures the provision of hot water and constant temperatures. Reacting to the difference in pressure the valve opens or shuts the heating water and the cold water inlet to the exchanger. Simultaneously, the temperature of the hot water is controlled by a thermostat. The PT-controller closes so that maximum power is used for the domestic hot water processing.



Return Temperature Limiter

Used for controlling the return temperature in the HERZ HIU between 25-60°C.

Limitation and locking of the set value range can be achieved by means of stop pins, which need to be ordered separately.



Return Temperature Limiter

Used for controlling the return temperature in the HERZ HIU between 25-60°C.

Limitation and locking of the set value range can be achieved by means of stop pins, which need to be ordered separately.



Actuating drive

Electro thermal actuating drive for heating regulation valves, installation in combination with an electrical room thermostat for twopoint- regulation in heating and cooling systems.



Thermostatic valve

Thermostatic valve, straight model, valve body made of brass, nickel-plated, steel spindle made of stainless steel, seals made of EPDM. Thread for Thermostatic head M 28 x 1,5.



Pressure Relief safety valve

Housing made of forged brass, EPDM Diaphragm, cap seals and plastic.

Temperature range is from 0 °C to +110 °C.

Pressure up to 2,5 bar.



Thermostatic bypass valve

HERZ thermostatic valve, nickel coated brass, with screw cap. In the HERZ HIU Manchester, this valve is installed in a bypass.



Automatic Air Vent

Forged brass version, with EPDM seal, PN 10, G thread, for heating systems. For all nonaggressive fluids such as water, oil, air, steam, fuel and lubricating oil. Working temperature 0 C to +110 C.



Circulating pump

Wilo-EAS-15/4-3P;



Premounting unit

Supplied as first fix mounting rail, complete with ball valves for isolating heating, cold- and hot water circuits, connection to the ball valves is possible from the wall, or underneath. The HIU can be connected at a later date by using the connections and fittings included. The HERZ premounting unit needs to be ordered separately.



5. Operating data

For providing hot water:

With fitted flow rate limiter: 15 [l/min]

Inlet pressure: 2,8 [bar]

| | |
|----------------------------------------------|-----|
| Amount of water drawn in l/min | 15 |
| Temperature of cold water in °C | 10 |
| Pressure drop in kPa | 25 |
| Flow rate in l/h | 880 |
| Hot water temperature in °C | 50 |
| Heating capacity of the heat exchanger in kW | 10 |

6. Dimensions of the HIU

| Dimensions of the HERZ HIU | |
|---------------------------------------------------|-------------------|
| <i>Dimension of the connections, inlet/outlet</i> | |
| Supply flow district heating plant | G 3/4 male thread |
| Return flow district heating plant | G 3/4 male thread |
| Cold water inlet/-outlet | G 3/4 male thread |
| Hot water outlet | G 3/4 male thread |
| Heating flow | G 3/4 male thread |
| Heating return | G 3/4 male thread |

Distribution of the connections:

1. Flow district heating plant
2. Return district heating plant
3. Cold water supply
4. Cold water outlet
5. Hot water outlet
6. Heating flow
7. Heating return

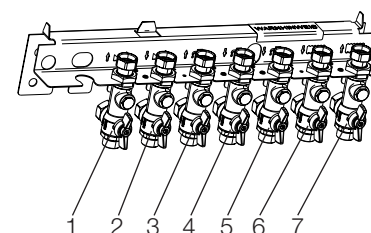

7. Construction

Due to its compact design the HERZ- HIU can be surface or flush mounted, so the HERZ HIU can be installed in any convenient position (e.g.: instead of a classic hot water tank).

The HERZ-HIU can be delivered in two versions, as a surface mounted or flush mounted version. In both cases the substation is mounted on a metal steel plate and either fitted in the inwall unit or surface mounted and fitted with the cover. The pre mounting unit needs to be ordered separately and can be fitted at first fix stage, the HIU can be installed at a later stage.

Either the heating circuit or the domestic hot water can be isolated by closing the ball valves, so in a case of malfunction the problems can be solved independently from each other.

All elements of the HERZ- HIU are mounted with detachable connections so they can be changed or maintained.

8. Function schematic HIU Manchester

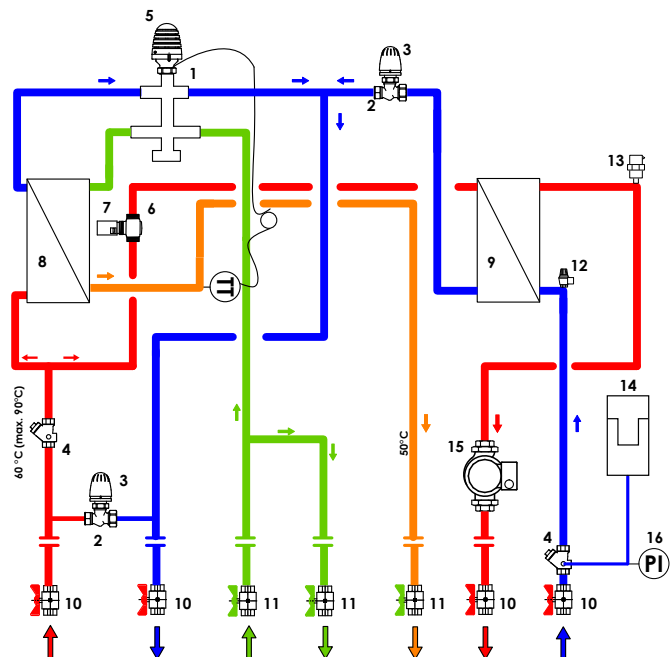

| | |
|----|------------------------------------------|
| 1 | HERZ- PT - controller |
| 2 | HERZ- thermostatic bypass valve |
| 3 | HERZ- return temperature limiter |
| 4 | HERZ- strainer |
| 5 | HERZ- thermostatic head with hydrosensor |
| 6 | HERZ- thermostatic valve |
| 7 | HERZ- actuating drive |
| 8 | Heat exchanger |
| 9 | Heat exchanger |
| 10 | HERZ- ball valve |
| 11 | HERZ- ball valve for drinking water |
| 12 | HERZ- Safety valve for heating |
| 13 | HERZ- Automatic air vent |
| 14 | Expansion vessel |
| 15 | Circulating pump |
| 16 | Pressure gauge |

System description:

The system comprises of a DHW heat exchanger (8) and a space heating heat exchanger (9). A Pressure Temperature control valve (1) controls the operation and temperature of the DHW system and a zone valve (6&7) controls the operation of the space heating from a temperature controller wired into the HIU.

The HERZ pressure and temperature controller (1) is built in as the central unit in the HERZ HIU Manchester, which ensures the provision of hot water and constant temperatures. Reacting to the difference in pressure the valve opens or shuts the heating water and the cold water inlet to the exchanger, and simultaneously the temperature of the hot water is controlled by a thermostat. Furthermore the integrated circulating pump (15) ensures a constant circulation of the heating water. An expansion vessel (14), in the HIU, holds the pressure in the system on a constant level and a pressure relief safety valve (12) is also fitted.

9. Connecting to the district heating main

The HIU is connected parallel to the district heating main. If possible, the unit should be installed before the first end user.

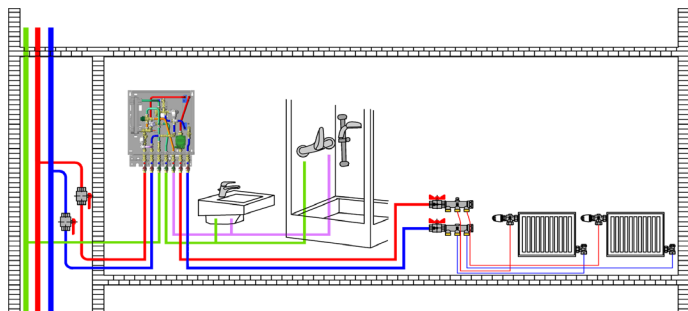

10. Operating conditions

Besides the national rules and regulations, the industrial standards as well as the connection conditions of the local water supplier need to be met and, furthermore, installation and operating instructions need to be followed.

The room where the HIU will be installed should be frost-free and the place of installation has to be chosen in such a way that the unit is easily accessible for maintenance and repair work. The incoming water temperature should range between a minimum of 60 °C and a maximum of 80 °C. A primary static pressure of 10 bar and a primary differential pressure of 0.5 bar are fine. Furthermore, in case of system failure, all connecting pipes must be able to withstand a maximum temperature of 95 °C.

11. Starting-up

The HERZ HIU is easy to operate and user-friendly. All you have to do is open up the ball valves in the following order so as to avoid water hammer:

1. Open heating water inlet slowly (red ball valve).
2. Open cold water inlet slowly (green ball valve).
3. Open heating water return slowly (red ball valve).
4. Open hot and cold water outlet slowly (green ball valve).

12. Temperature setting

The HERZ HIU Manchester is set to a default temperature of max. 55 °C. The settings of the thermostat cannot be changed to ensure the optimal tap water temperature at all times.

13. Initial start-up

In accordance with the Austrian ÖNORM H5195-1 standard, before initially starting up the HERZ HIU, make sure to use only clean pipe materials that comply with standards (i.e., all pipe work must be free from forging scale, rust, burrs and impurities). The same holds true for fittings and units (boilers, radiators, convectors, expansion vessels, etc.). The Austrian ÖNORM H5195 standard further provides for clean and professional workmanship (without welding beads, sealing or solder residues, burrs, bore chips and others) and cleaning of all components prior to their installation.

Strainers should be fitted because deposits in the pipes can damage the controller and impurities can enter the drinking water system.

To prevent corrosion in the heating system, the Austrian ÖNORM H5195-1 standard requires the following measures:

When installing and operating the heating system, make sure that as little air as possible enters the closed heating circuit.

Before initially starting up the heating plant, flush it through twice (so that the entire water contained in the system is replaced twice). Then fill with clear, filtered water (filtered with a ≤ 25 µm pore size filter) of the required quality standard. When first starting up the heating system, it must be kept running at normal operating conditions for 24 hours so that the heating water is evenly mixed with the inhibitor. Old heating systems must be treated with a chemical cleanser and then flushed with water

before refilling them.

Do not partially or entirely drain the heating system, leaving it without anti-corrosion treatment for a prolonged period of time; otherwise the system will be more susceptible to corrosion.

To avoid damage by frost at low temperatures, the heating system must be protected in compliance with the Austrian ÖNORM H5195-2 standard as follows:

In general, anti-freeze and water can be mixed to any percentage. However, heating systems with circulation pumps should be filled two thirds with water, then the anti-freeze added and only then should the system be topped up with water. The anti-freeze will be thoroughly mixed with the water once the system is put into operation and the fluids start circulating.

Gravity-fed heating systems, however, must be filled with a combined anti-freeze and thermal fluid.

If anti-freeze needs to be put into a heating system that has so far been unprotected, the following must be observed:

1. Ensure that the anti-freeze is suitable for the sealing materials.
2. The system should be power flushed.
3. After having added the anti-freeze, the system must be double checked for leaks.

In order to be able to do this, HERZ recommends using the HERZ multifunction ball valves on the inlet and return pipes (order no.: 1 2414 xx and order no.: 1 2415 xx, respectively).

14. Shutting down, emptying

Shutting down the HERZ HIU for a prolonged period of time or dismantling it for whatever reason is done by shutting all ball valves.

In rooms exposed to temperatures below freezing the HERZ HIU must be drained down prior to the start of the cold season if the unit is to be shut down for several days. To drain the HIU, place a vessel with a capacity of 4 to 8 litres underneath the unit and drain the hot water from the ball valves till the HERZ- HIU is completely empty.

If temperatures are liable to drop below freezing point, be aware that not only the water in the HERZ HIU and the hot water pipes may freeze but also the water in the cold water inlet pipes leading to the fittings and to the unit itself. Therefore it is best to drain all water pipes and pipe fittings up to the frost-proof part of the domestic heating system.

15. Servicing and maintenance

Owing to its outstanding design, the HERZ HIU requires comparably little maintenance work. However, in hard water areas lime-scale can build up in the system. Depending on the hardness of the water, your system should be de-scaled by a professional every one to two years. In case scale in the system has damaged the valves, these should be replaced immediately to ensure smooth operation of your heating system.

Do not clean the unit with scouring or harsh cleaning products. Wipe it down with a damp cloth which has been rinsed in water with a few drops of mild detergent.









Heat exchanger



| Parameters | Recommended limits for the tap water quality on the secondary side |
|--------------------------|-----------------------------------------------------------------------------------------------------------------------------------------------------------------------------------|
| Temperature | Depends on the composition of the water, but under 60°C, to reduce the risk of stress corrosion of the stainless steel and pitting corrosion in the copper through the hot water. |
| PH-value | 7-9 |
| Alkalinity | 60 mg/L < [HCO ₃ ⁻] < 300 mg/L |
| Conductivity | < 500 µS/cm |
| Hardness | [Ca ²⁺ ,Mg ²⁺]/[HCO ₃ ⁻] > 0,5 |
| Chloride | 1000 mg/L at 25 °C 300 mg/L at 50 °C 100 mg/L at 80 °C 0 mg/L at T > 100 °C |
| Sulphate | [SO ₄ ²⁻] < 100 mg/L and [HOC ₃ ⁻]/[SO ₄ ²⁻] > 1 |
| Nitrate | [NO ₃ ⁻] < 100 mg/L |
| Free chlorine < 0,5 mg/L | |

Note:





The given reference values of the heat exchanger producer are considered with regard to the required water quality.

16. Spare parts

| Article | |
|----------------------------|---------------------------------------------------------------------------------------|
| PT- controller |  |
| Thermostat |  |
| Return temperature limiter |  |
| Thermostatic bypass valve |  |
| Thermostatic zone valve |  |
| Safety valve for heating |  |
| Automatic air vent |  |
| Circulating pump |  |
| Actuator |  |

| | |
|------------------------------|-----------------------------------------------------------------------------------|
| Heat exchanger DHW |  |
| Heat exchanger Space heating |  |

17. Accessory

| | |
|---------------------------------------------------------------------------------------------------------------------------------------------------------------------------------------------------------------------------------------------------------------------------------------------------------------------------------------------------------------------------------------------------------------------|------------------------------------------------------------------------------------|
| Premounting unit |  |
| HERZ- Inwall unit Inwall unit made of zinc coated steel, with mounting frame. - Front frame and door white powder coated (RAL 9003), door with lock |  |
| Electronic Room Temperature Controller 1 change-over contact Set value range 10-30 °C Switching difference ± 0.2 K fixed |  |
| Room Temperature Controller For individual time and temperature programmable adjustment. Digital timer with program on a weekly and yearly basis, automatic switching between summer and winter time. <ul style="list-style-type: none"> • Set value range 8-38 °C • Switching difference as 2-point controller 0.4-8 K • Metering precision 0.3 K at a temperature of 20 °C |  |

18. Troubleshooting, malfunctioning

Problem: The hot water temperature is too high

Solution: The HERZ PT controller must be checked and, if necessary, replaced by a qualified and approved plumbing and heating engineer.

Problem: The hot water temperature is too low

Solution: The heat exchanger must be checked and, if necessary, replaced by a qualified and approved plumbing and heating engineer. Check with your district heating provider whether there is a failure in their system. Check that the red ball valves are turned on. The thermostat controller must be checked and, if necessary, replaced by a qualified and approved plumbing and heating engineer. The whole system must be checked by a qualified and approved plumbing and heating engineer for scale buildup.

19. Recycling and disposal

The HIU as well as the packaging are mainly made of recyclable raw material.

Substation

The HIU and accessories should be disposed of sensibly and properly and not in household waste.

Packaging

- The disposal of the packaging is the responsibility of the installer.

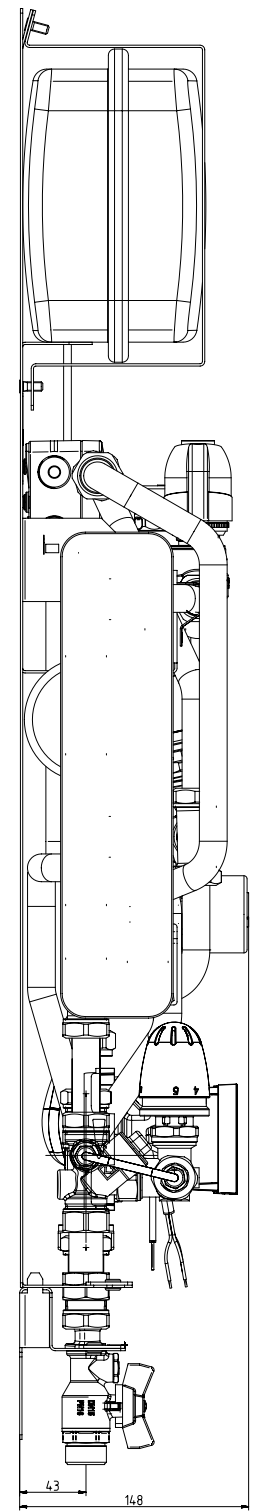
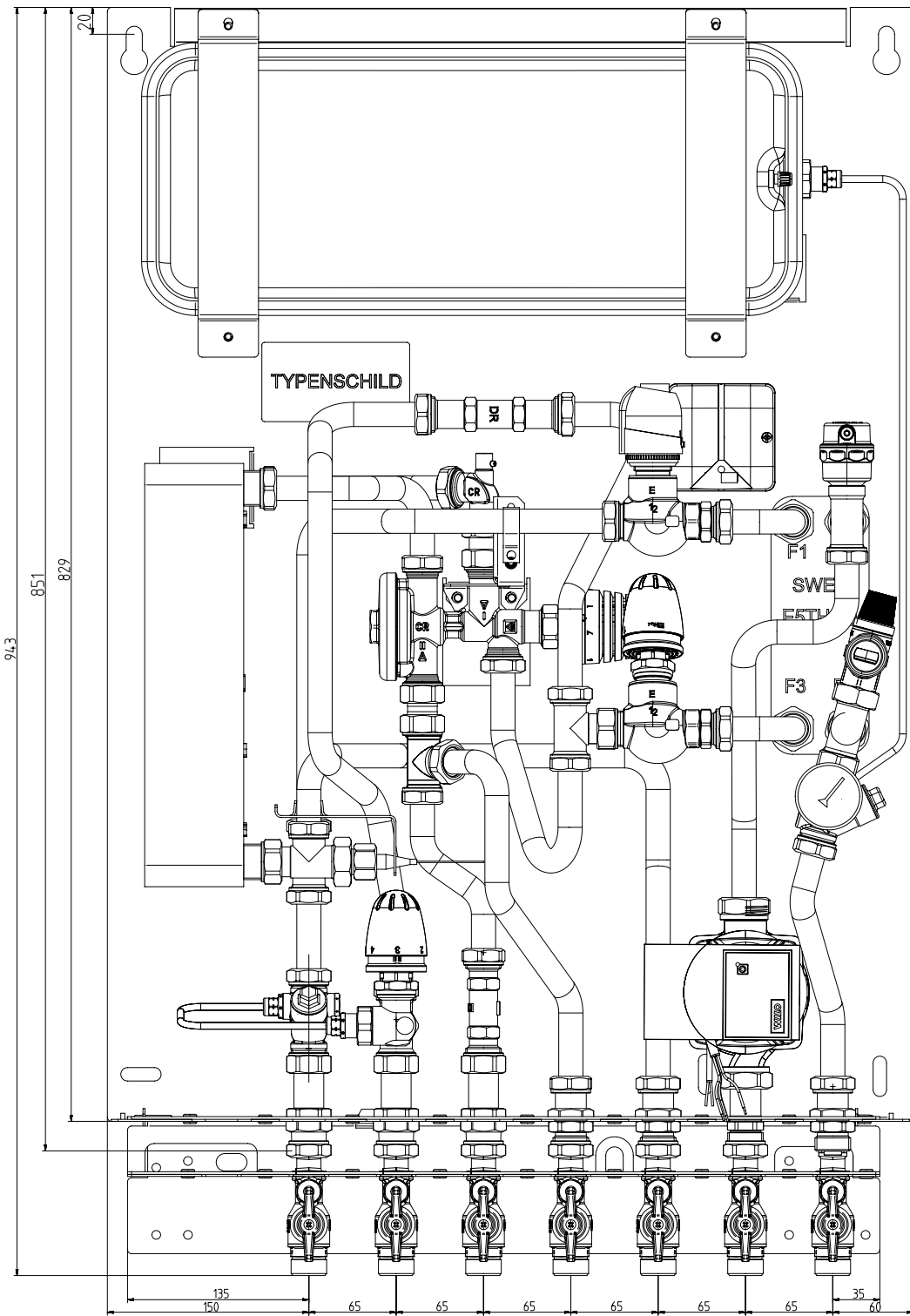

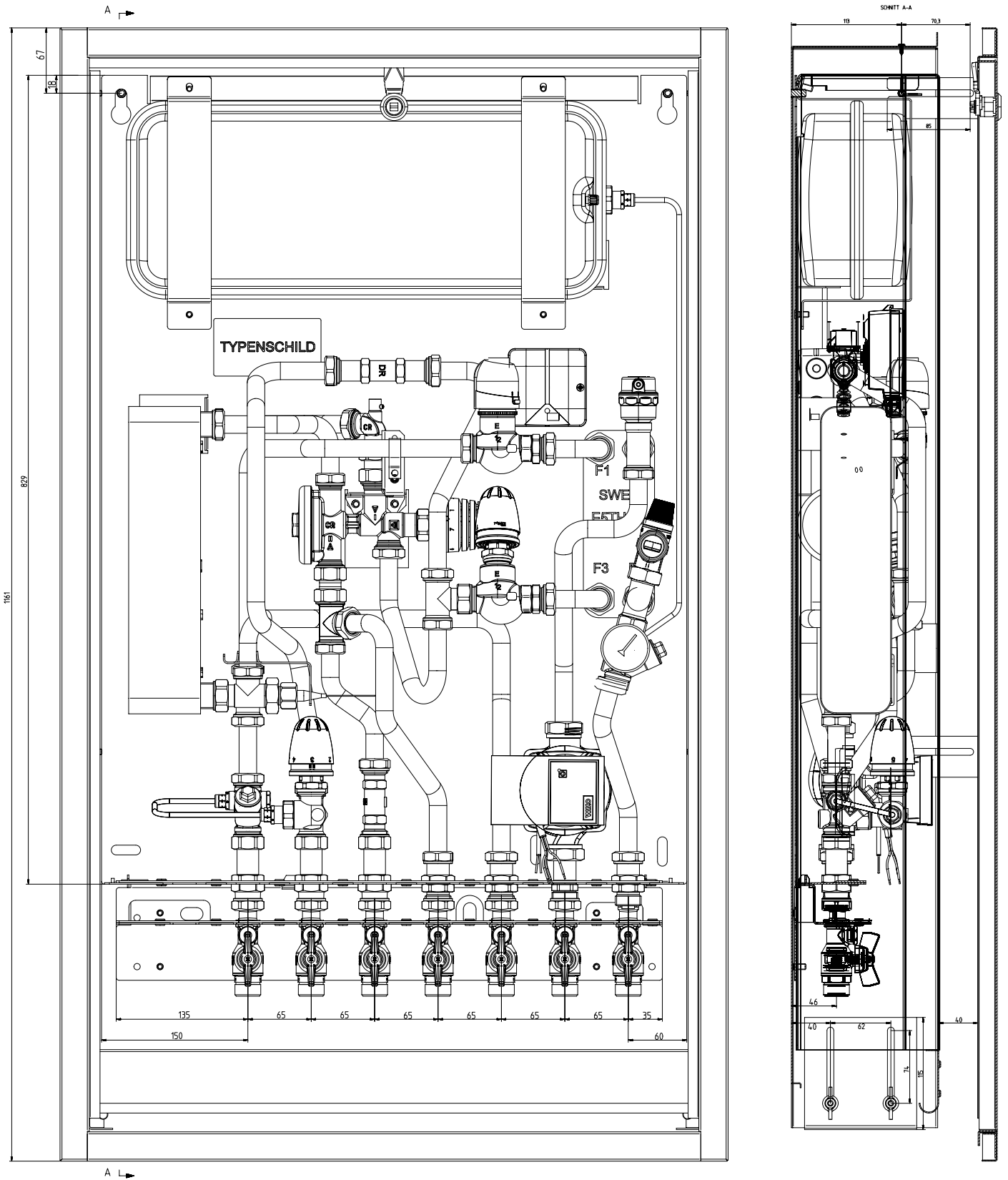

Please note: all diagrams are indicative in nature and do not claim to be complete. All specifications and statements within this brochure are according to information available at the time of printing and meant for informational purpose only. Herze Armaturen reserves the right to modify and change products as well as its technical specifications and/or its functioning according to technological progress and requirements. It is understood that all images of Herze products are symbolic representations and therefore may visually differ from the actual product. Colours may differ due to printing technology used. In case of any further questions don't hesitate to contact your closest HERZE Branch-office. BA_WUS-49_0313_3