

HERZ® CF Light Instruction manual

FOR INSTALLER

COMPACTFLOOR Light

3 E533 23-32

3 E533 33-42

3 F533 73-82

ISSUE 0921

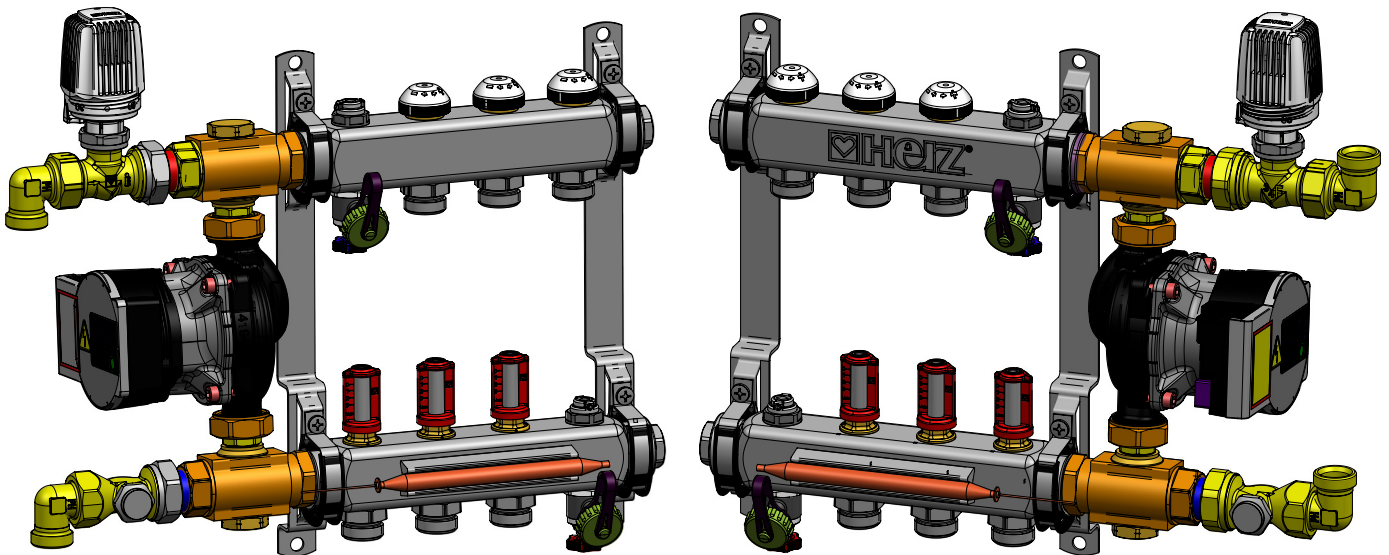

INSTALLATION AND INSTRUCTION MANUAL

HERZ Armaturen GmbH
Richard-Strauss-Str. 22, 1230 Vienna
Tel.: +43 (0)1 616 26 31-0
Fax: +43 (0)1 616 26 31-227
E-Mail: office@herz.eu

www.herz.eu

☑ Introduction

The COMPACTFLOOR Light is a control station ready for connection, including a high efficiency circulation pump for connecting 3 to 12 heating circuits of a panel heating system. Distribution manifolds made of brass for the supply and return guarantee the flushing of the panel heating circuits, as well as drainage and venting of the system. The supply distributor is equipped with control inserts and flow indicators and the return distributor is equipped with upper thermostatic inserts. The fixed value control is implemented mechanically by a thermostatic head with a contact sensor and the thermostatic valve. An HERZ-RL-5 return valve with pre-setting is installed in the return.

Advantages of the COMPACTFLOOR Light:

- Enables the individual heating of rooms
- Individually adjustable depending on user behaviour and temperature requirements
- Minimal space required and fast assembling
- Low return temperature
- Simple operation of the system
- Optimum thermal comfort

☑ Safety information

- Assembly and installation must be performed exclusively by licensed and specially trained fitters.
- Damaged COMPACTFLOOR Light parts and components must be replaced with original or alternative suitable and technically equivalent spare parts.
- Prior to starting the system up, check all connection points for leak-tightness.
- Following installation, check that all screws are mechanically secure.
- It is prohibited to technically modify the system. The user must not implement technical changes to the device because no liability will be accepted for any resultant damage to the system.

☑ Function

The hot water entering the supply is regulated to the target temperature by the thermostat with a contact sensor. The target temperature can be adjusted between 20 °C and 50 °C (for dimensioning see PIPEFIX-leaflet) by using the hand wheel. Upon reaching the target temperature setting, the thermostatic valve closes and return water is added via the bypass line until the target temperature setting is undercut at the thermostatic head with contact sensor. Once the water temperature drops below set point the thermostatic valve opens again. Depending on the version, it is possible to connect 3 to 12 underfloor heating circuits. The supply distribution manifold is equipped with flowmeters for presetting the desired quantity of water per heating circuit. Thermostatic inserts, equipped with thermal actuators, are installed in the return distribution manifold for an individual room temperature control. A high efficiency circulation pump is installed for hot water circulation on the secondary side.

☑ Functional schematic

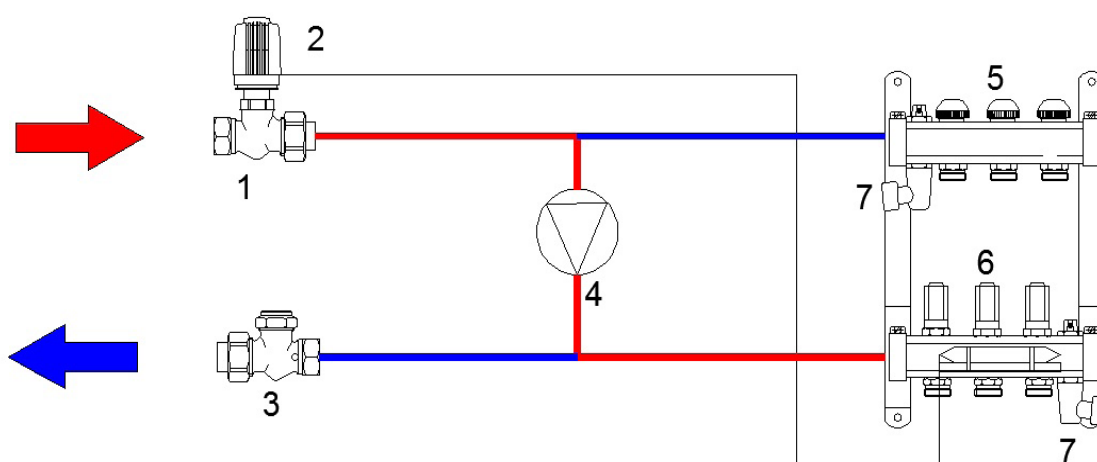

- | | | | |
|---|--|---|--------------------------|
| 1 | Thermostatic valve TS-90 | 5 | Thermostatic inserts |
| 2 | Thermostatic head with remote contact sensor | 6 | Control inserts |
| 3 | Return valve RL-5 | 7 | Fill and drain connector |
| 4 | High efficiency circulating pump | | |

☑ Return valve RL-5 und TS 90

The return valve HERZ RL-5 installed in the return is set to the total quantity of water for all heating circuits according to the diagram (see page 7).

Presetting RL-5:

- Unscrew cap.
- Use the multi-purpose wrench to close the valve (turn to the right, max. torque 6 Nm).
- Using the Herz key 1 6639 01 or a screwdriver, turn the presetting screw (3 mm) to the right until it reaches the mechanical stop. From this position, adjust by turning to the left to the desired presetting stage according to the standard diagram, whereby one revolution equals one presetting stage
- Using the multi-purpose wrench, open the valve until it reaches the mechanical stop (turn to the left).
- Unscrew the cap with seal (tightening torque or moment 5 – 10 Nm).



Attention: The HERZ-RL-5 valve is supplied from the factory with the valve and presetting fully open. The presetting

spindle must not be turned further to the left from this position. The screw head must not protrude out of the main spindle!

The thermostatic valve HERZ TS-90 (see diagram page 8) is equipped with a thermostatic head with contact sensor and serves as a zone and temperature control valve. The target temperature can be read off and adjusted directly at the hand wheel.

☑ Installation instruction

- During assembly, observe the dimensioned sketches and information signs provided with the device. Observe the assembly instructions.
- When selecting the assembly side take into consideration the weight of the COMPACTFLOOR, including the weight of the water in the system.
- During assembly ensure that the mounting wall is straight, to ensure that the the COMPACTFLOOR is secured correctly.
- If parts are retrofitted to the COMPACTFLOOR or it is installed in small rooms, it is essential to ensure that the front of the device remains freely accessible for repairs. Ensure sufficiently large ventilation openings, in order that the maximum permissible temperature for electrical parts is not exceeded.
- It is necessary to select wall plugs and screws appropriate for the mounting surface.

☑ Technical data

- max. operational temperature 110 °C in supply line
- min. operational temperature -25 °C with frost protection agent glycol to a maximum of 50 Vol.- %
- max. operational pressure 10 bar
- max. heat load ca. 8 kW (see pre-setting diagram on page 7)
- min. differential pressure 30 kPa in supply line

☑ Operating conditions

The room in which the system is operated should be frost-free and assembly should take place at a location that is freely accessible for the required maintenance and repairs. 10 bar static and 0.5 bar differential pressure are permitted on the primary side. Furthermore, it is necessary to note that the connection pipes must be capable of withstanding constant operation at a maximum temperature of 110 °C in the event of a defect.

☑ First commissioning

Prior to first commissioning of the COMPACTFLOOR Light, according to ÖNORM H5195-1 it is necessary to note that clean and standard-compliant pipe materials (without scale, rust and inner burrs, as well as contamination), fittings and devices (boiler, radiators, convector heaters, expansion vessels, etc.) must be used. Furthermore, ÖNORM H5195 also requires clean and professional production (without welding beads, sealing material residues or soldering aids, burrs, metal shavings and similar), as well as the cleaning of all heating system parts prior to their installation. Otherwise damage to the controller may arise due to the deposits in the pipes.

The set-up and operation of the heating system must take place such that air entering the closed heating system is prevented insofar as possible. When commissioning the heating system for the first time, flush the secondary side through with a quantity at least 2 times the volume of the system. Afterwards, fill the heating system with clear, filtered water (pore size < 25 µm) with water quality in accordance with ÖNORM H 5195. Avoid partially or completely emptying the heating system for extended periods of time without treating it, because this may result in intensified corrosion processes in the system. In order that sufficient frost protection of the system is guaranteed with low temperatures, the hot water quality must comply with ÖNORM H5195 and the requisite antifreeze must be added.

Although antifreeze is miscible with water at any ratio, systems with pumps should initially be filled with roughly two thirds of the required quantity of water. The antifreeze should then be added to the system with water. Through mixing is achieved by starting up the circuit. However, gravity systems should be filled with prepared, frost-protected heat mediums. If it is necessary to add antifreeze to heating systems that have not previously been protected against frost then observe the following points:

- It is necessary to ensure that the sealing materials are suitable for this.
- The systems should be carefully flushed through.
- After adding antifreeze it is necessary to watch for any leaks even more carefully.

☑ **COMPACTFLOOR Light models**

- **COMPACTFLOOR Light with high efficiency circulating pump, connection from the bottom left**

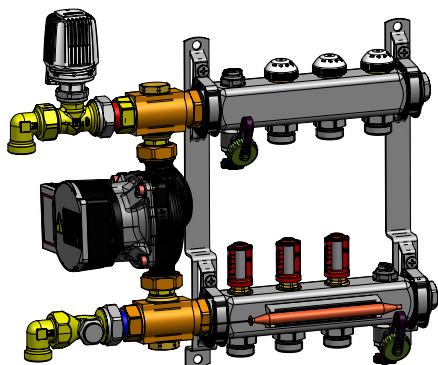

COMPACTFLOOR Light models with high efficiency circulating pump	
3-outlet	3 E533 23
4-outlet	3 E533 24
5-outlet	3 E533 25
6-outlet	3 E533 26
7-outlet	3 E533 27
8-outlet	3 E533 28
9-outlet	3 E533 29
10-outlet	3 E533 30
11-outlet	3 E533 31
12-outlet	3 E533 32

- **COMPACTFLOOR Light with high efficiency circulating pump, connection from the top right**

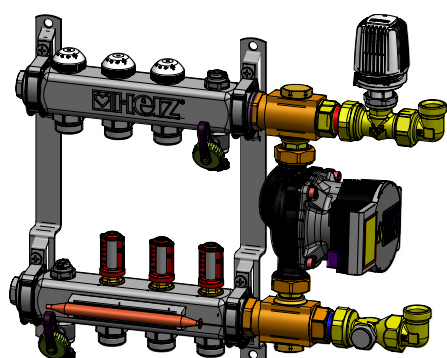

COMPACTFLOOR Light models with high efficiency circulating pump	
3-outlet	3 E533 33
4-outlet	3 E533 34
5-outlet	3 E533 35
6-outlet	3 E533 36
7-outlet	3 E533 37
8-outlet	3 E533 38
9-outlet	3 E533 39
10-outlet	3 E533 40
11-outlet	3 E533 41
12-outlet	3 E533 42

- **COMPACTFLOOR Light without pump, connection from left**

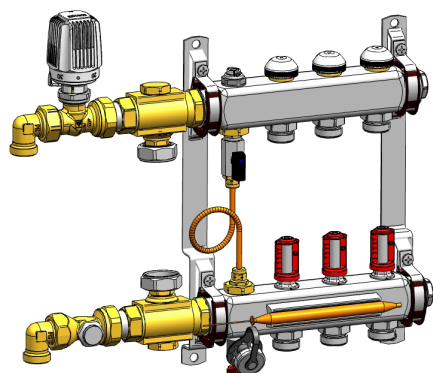

COMPACTFLOOR Light models without pump	
3-outlet	3 F533 73
4-outlet	3 F533 74
5-outlet	3 F533 75
6-outlet	3 F533 76
7-outlet	3 F533 77
8-outlet	3 F533 78
9-outlet	3 F533 79
10-outlet	3 F533 80
11-outlet	3 F533 81
12-outlet	3 F533 82

NOTE: when using high efficiency circulating pump the bypass has to be closed

- **COMPACTFLOOR Light without pump, connection from right**

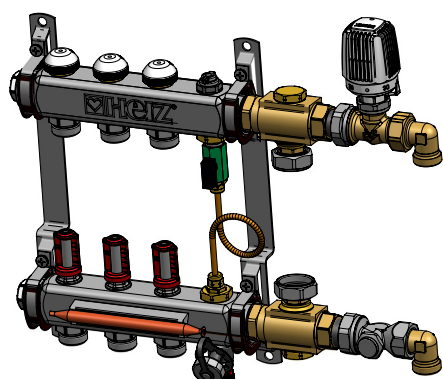

COMPACTFLOOR Light models without pump	
3-outlet	3 F533 83
4-outlet	3 F533 84
5-outlet	3 F533 85
6-outlet	3 F533 86
7-outlet	3 F533 87
8-outlet	3 F533 88
9-outlet	3 F533 89
10-outlet	3 F533 90
11-outlet	3 F533 81
12-outlet	3 F533 82

NOTE: when using high efficiency circulating pump the bypass has to be closed

☑ Dimensions COMPACTFLOOR Light

3 F533 23-32

3 F533 33-42

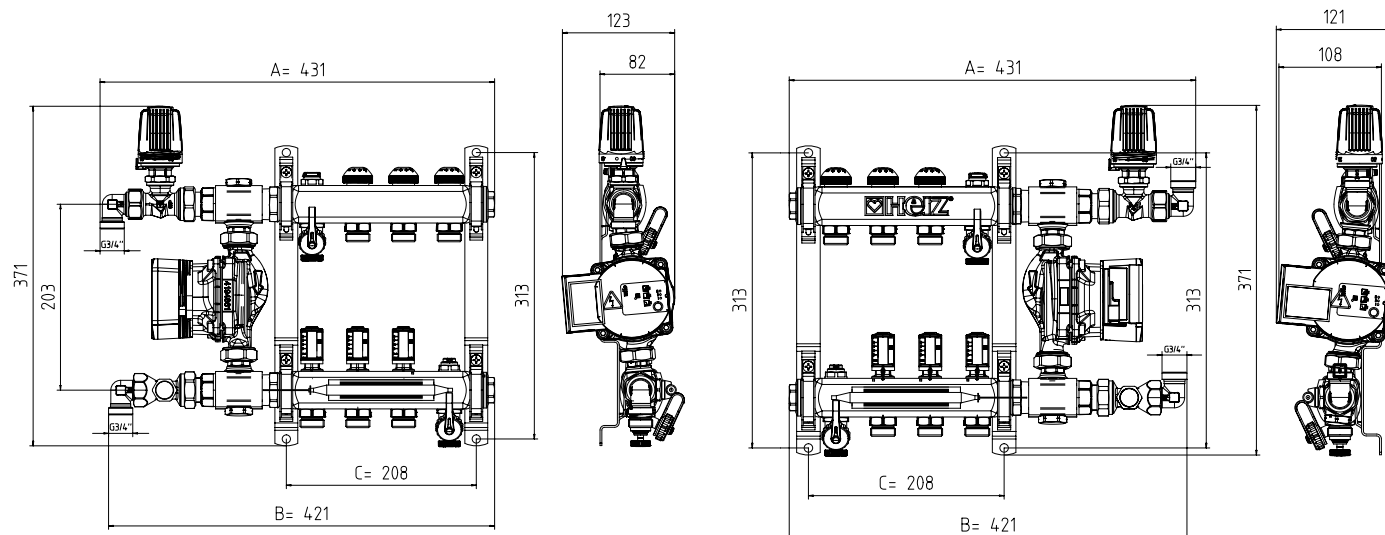

Dimensions COMPACTFLOOR Light

	3E53323	3E53324	3E53325	3 E533 26	3 E533 27	3 E533 28	3 E533 29	3 E533 30	3 E533 31	3 E533 32
	3E53333	3E53334	3E53335	3 E533 36	3 E533 37	3 E533 38	3 E533 39	3 E533 40	3 E533 41	3 E533 42
	3-outlet	4-outlet	5-outlet	6-outlet	7-outlet	8-outlet	9-outlet	10-outlet	11-outlet	12-outlet
A [mm]	417	467	517	567	617	667	717	767	817	867
B [mm]	405	455	505	555	605	655	705	755	805	855
C [mm]	190	240	290	340	390	440	490	540	590	640

Due to the small dimensions and compact design it is possible to flush-mount the COMPACTFLOOR and therefore install it either in the stairwell or in the apartment. Flush box has to be ordered separately.

☑ Dimensions COMPACTFLOOR Light flush box

The dimensions vary depending on the number of heating circuits (see table below).

Flush box	Width B [mm]	Height [mm]	Depth [mm]	Inner width C [mm]	Order number
3-7 outlet	750	720 - 805	150 - 190	684	1 8570 50
8-10 outlet	900	720 - 805	150 - 190	834	1 8570 51
11-12 outlet	1050	720 - 805	150 - 190	984	1 8570 52

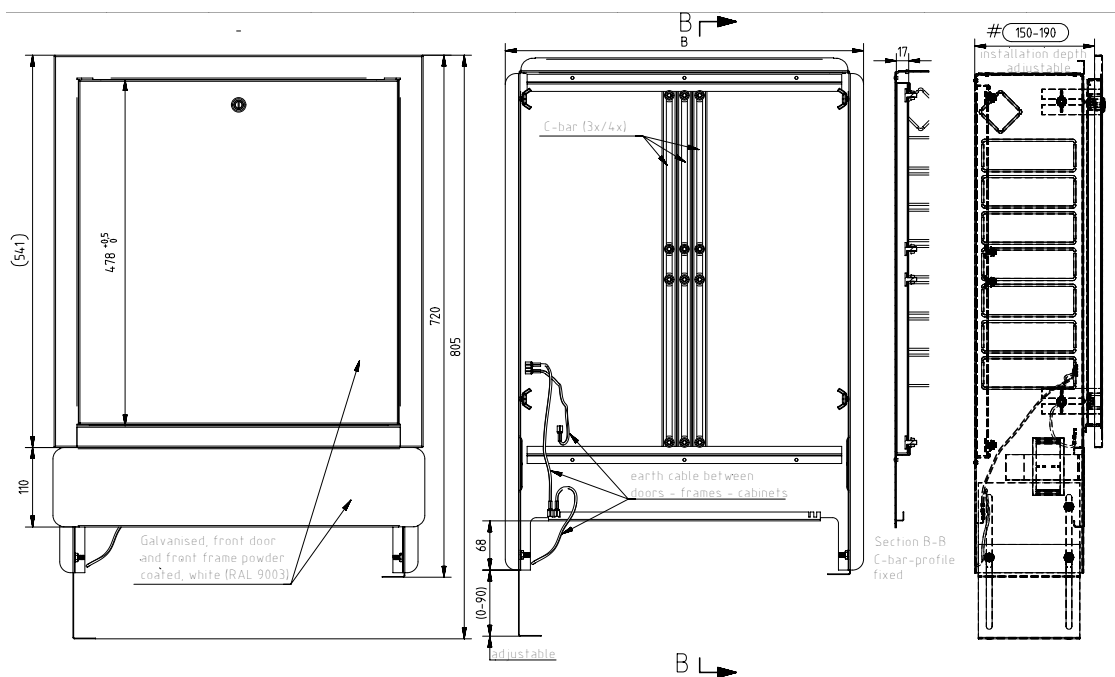

HERZ Standard Diagram

RL-5, DN 20 straight model

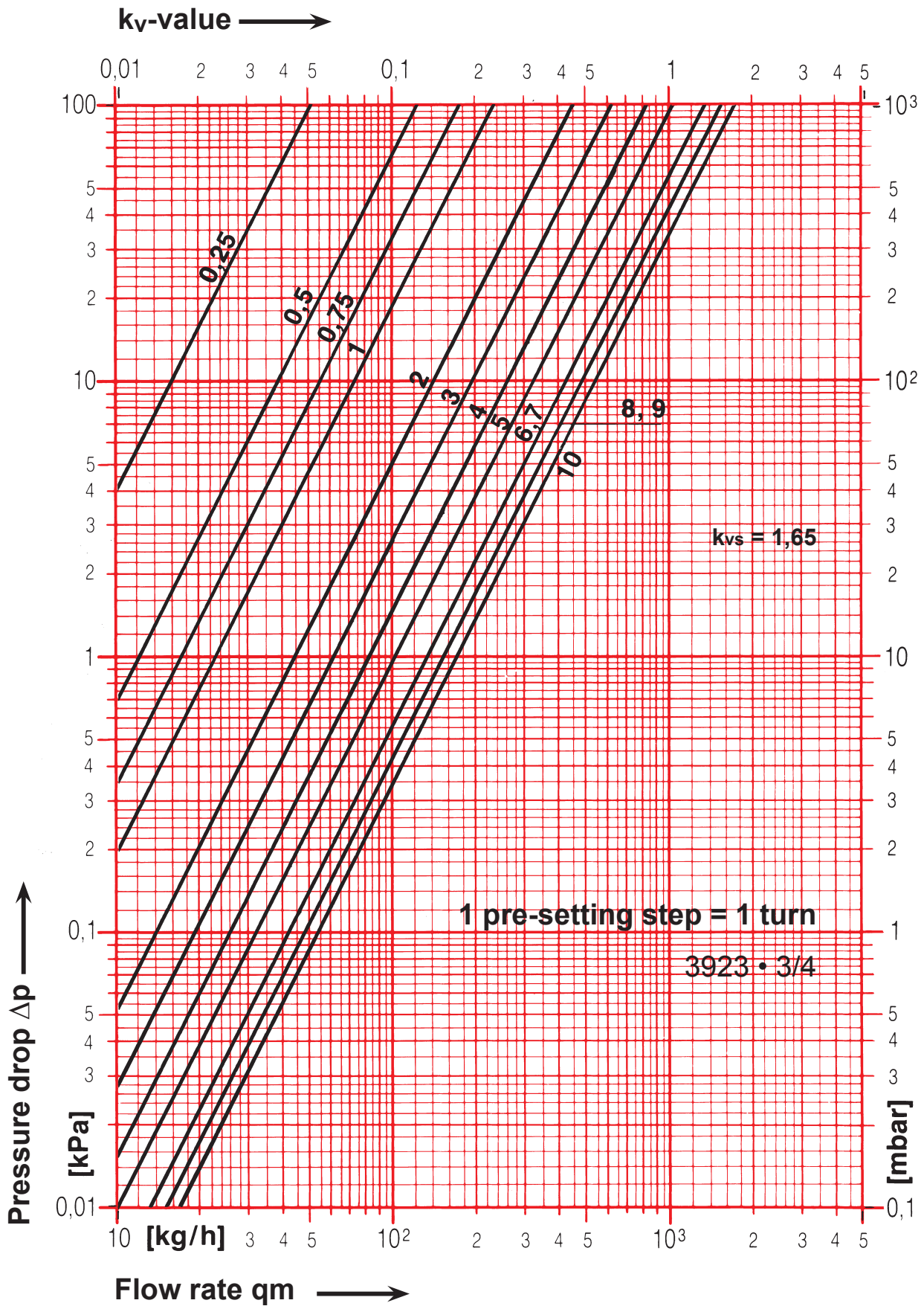
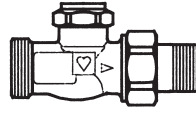

HERZ-Normdiagramm

TS-90, DN 20 straight model

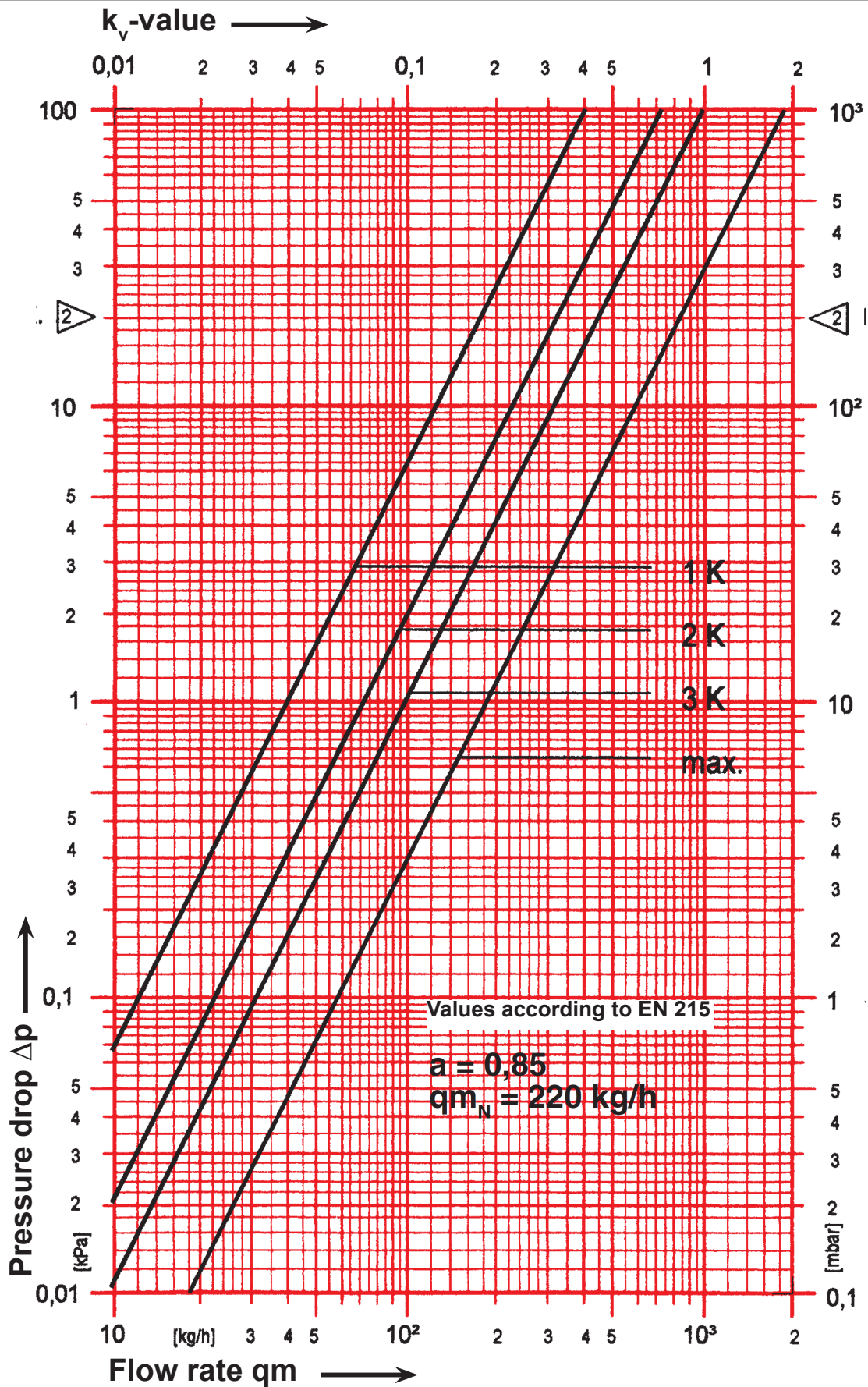
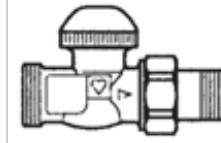

☑ Function principle of components

The factory setting is fully open and be adjusted by using the adjustment key. The set amount of the flow volume can be read directly at the inspection glass. To adjust the flow volume or close the valve use plastic adjustment key on top of the knurl and rotate clockwise or counter-clockwise.

Conversion table [l/min] --> [l/h]

Flowmeter 0-3 l/min

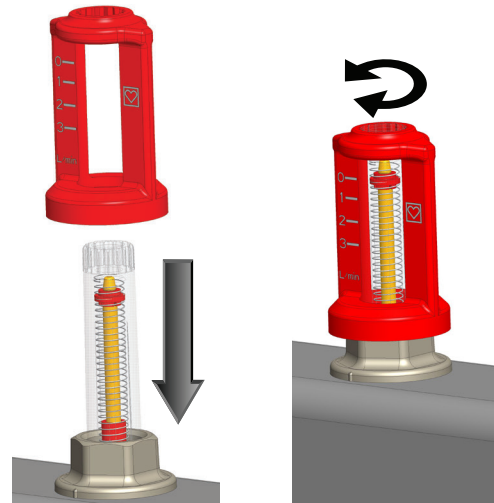
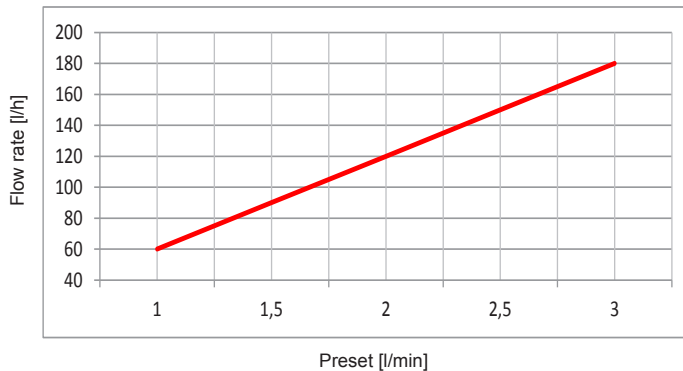

☑ Replacing the thermostatic valve upper part

If necessary, it is possible to replace the HERZ thermostatic valve upper part TS-90 under pressure using the HERZ-Changefix (1 7780 00).

Cleaning the seat gasket at the spindle or replacing the thermostatic upper part. In this way it is simple to eliminate malfunctions, e.g. due to foreign bodies such as dirt, welding and soldering residues. During use observe the operating instructions provided with the replacement device.



HERZ-Changefix

☑ Temperature setting

The target temperature can be pre-set at the thermostatic head with contact sensor (see also corresponding leaflet) between 20 °C and 50 °C using the hand wheel, according to the configuration.

☑ Safety thermostat (available as spare part)

We recommend to use a safety thermostat when you install the COMPACTFLOOR Light. The HERZ safety thermostat 1 8100 00 is set 5 K higher than the target temperature according to the configuration. Maximum temperature setting is 50 °C.

Function: In the event of the thermostatic head with contact sensor failing, the contact thermostat serves as a protective element and prevents a temperature rise in the system through electrical isolation of the pump.



Safety thermostat
1 8100 00

☑ **High efficiency circulating pump (“E”-models)**

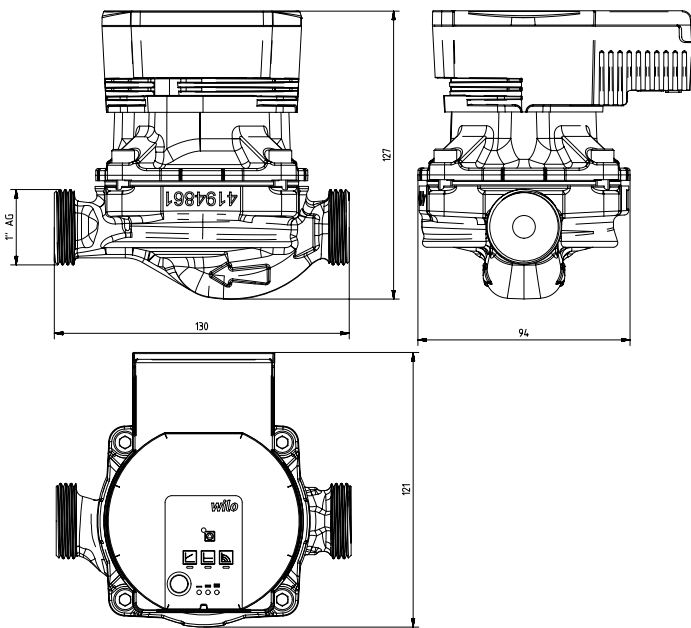

Type: Wilo - PARA 15-130/6 -43/SCU-3/N1,0
 Hmax. [m] 6,7
 Qmax. [m³/h] 3,2
 Temperature range 0 °C – 100 °C
 Standard model for operational pressure pmax [bar]: 10
 Power supply 1~ [V] : 230 V, +10 % / -15 %
 Frequency [Hz]: 50Hz/60Hz
 Protection class: IP X4D
 Cable length: 1,0 m
 Insulation class: F
 Installation length: 130 mm
 Connection: 1" male thread
 Power consumption: 3 - 43 W
 Minimum suction head at the suction connection for avoiding cavitation with water pumping temperature:
 Minimum suction head [m] at 50/95 °C - 0,5 / 4,5 m

☑ **Electrical connection work**

Electrical connection work or maintenance work must be carried out by licensed and trained tradesmen exclusively. It is necessary to observe the following laws and standards in particular during the installation:

- IEC 364-4-41/VDE 0100 part 410 Protection against electric shock
- IEC 364-3/VDE 0100 part 310 Protective measures against indirect contact with switch-off or signal
- IEC 364-4-1/VDE 0100 part 410 Protective devices and shut-off conditions
- ÖVE / ÖNORM E 8001 in the latest valid version.

Note: It is also necessary to observe national standards, guidelines and regulations.

Variable differential pressure ($\Delta p-v$):

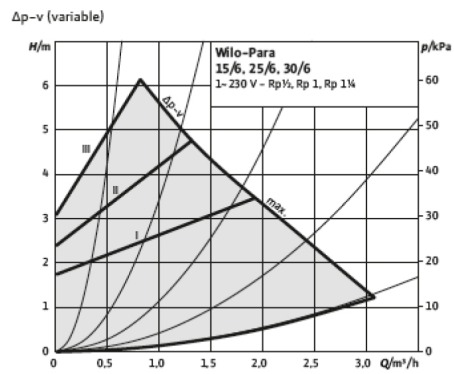

The target differential pressure value H is increased on a linear basis above the permissible pumped flow range between $\frac{1}{2}H$ and H. The differential pressure generated by the pump is regulated to the corresponding target differential pressure value. This form of regulation is particularly expedient in the case of heating systems with radiators because the flow noise at the thermostatic valves is reduced.

Constant differential pressure ($\Delta p-c$):

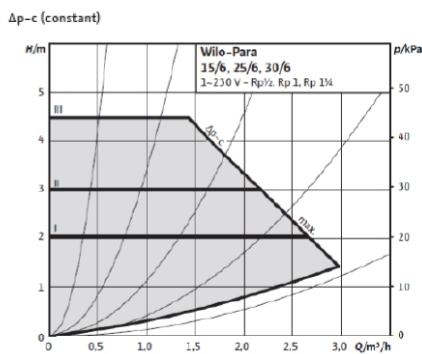

The target value H for the differential pressure is held constant at the set target differential pressure value above the permissible pumped flow range up to the maximum characteristic curve. Wilo recommends this form of regulation with underfloor heating circuits or older heating systems with pipes with large dimensions, and with all applications that do not have variable pipe network characteristic curves.

☑ Technical data for the electrical system

Operating temperature / ambient temperature: 0 °C - 40 °C

Supply voltage: 230 V/AC

Installation site: Indoors

EMC environment: B

Degree of pollution: 2

Elevation (above sea level) of installation site: to max. 2000 m

Overvoltage category: II

External mechanical influence (IK code): IK 05

Distributor fuse: T 4.0 A, varistor as overvoltage protection for the thermal actuators

Electrical connection with screw terminals for lines up to 1,5 mm²
CF Light pre-fuse: LSS 13 A

Suitable for operation with TT and TN networks

Highest rated operating voltage against ground: $U_1 = 300 \text{ Vac}$

Rated impulse strength: 2,5 kV

Max. electrical power input of CF Light only with pump				
Order Nr.	Model	Nominal voltage [V]	Electrical output [W]	Frequency [Hz]
3 E533 23	3-fach	230V/AC	3-43 W	50 Hz
3 E533 24	4-fach	230V/AC	3-43 W	50 Hz
3 E533 25	5-fach	230V/AC	3-43 W	50 Hz
3 E533 26	6-fach	230V/AC	3-43 W	50 Hz
3 E533 27	7-fach	230V/AC	3-43 W	50 Hz
3 E533 28	8-fach	230V/AC	3-43 W	50 Hz
3 E533 29	9-fach	230V/AC	3-43 W	50 Hz
3 E533 30	10-fach	230V/AC	3-43 W	50 Hz
3 E533 31	11-fach	230V/AC	3-43 W	50 Hz
3 E533 32	12-fach	230V/AC	3-43 W	50 Hz

Max. electrical power input of CF Light with connection box, actuators and pump				
Order Nr.	Model	Nominal voltage [V]	Electrical output [W]	Frequency [Hz]
3 E533 23	3-fach	230V/AC	46 W	50 Hz
3 E533 24	4-fach	230V/AC	47 W	50 Hz
3 E533 25	5-fach	230V/AC	48 W	50 Hz
3 E533 26	6-fach	230V/AC	49 W	50 Hz
3 E533 27	7-fach	230V/AC	50 W	50 Hz
3 E533 28	8-fach	230V/AC	51 W	50 Hz
3 E533 29	9-fach	230V/AC	52 W	50 Hz
3 E533 30	10-fach	230V/AC	53 W	50 Hz
3 E533 31	11-fach	230V/AC	54 W	50 Hz
3 E533 32	12-fach	230V/AC	55 W	50 Hz

☑ Spare parts list COMPACTFLOOR Light

Pos Nr.	Description	Order number
1	Thermostat with contact sensor	1 7420 06
2	Air vent	1 4020 59
3	HERZ-TS-Spare Upper Part	1 6403 31
4	Thermostatic valve TS-90	1 7723 92
5	Drain valve blue	1 8635 55
6	Drain valve red	1 8635 54
7	Flowmeter 0 - 3 l/min	3 F900 23
8	High efficiency circulating pump	3 E531 00
9	RL-5-return valve	1 3923 02

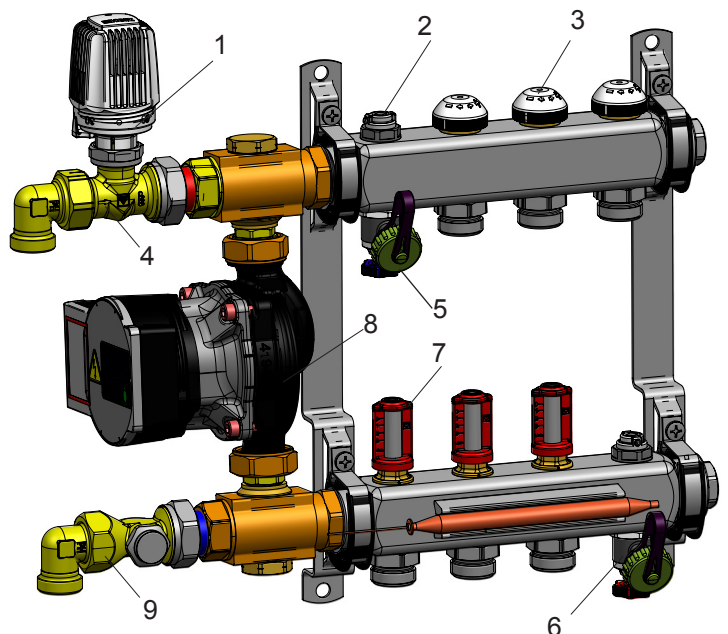

☑ Electrical wiring diagram COMPACTFLOOR Light

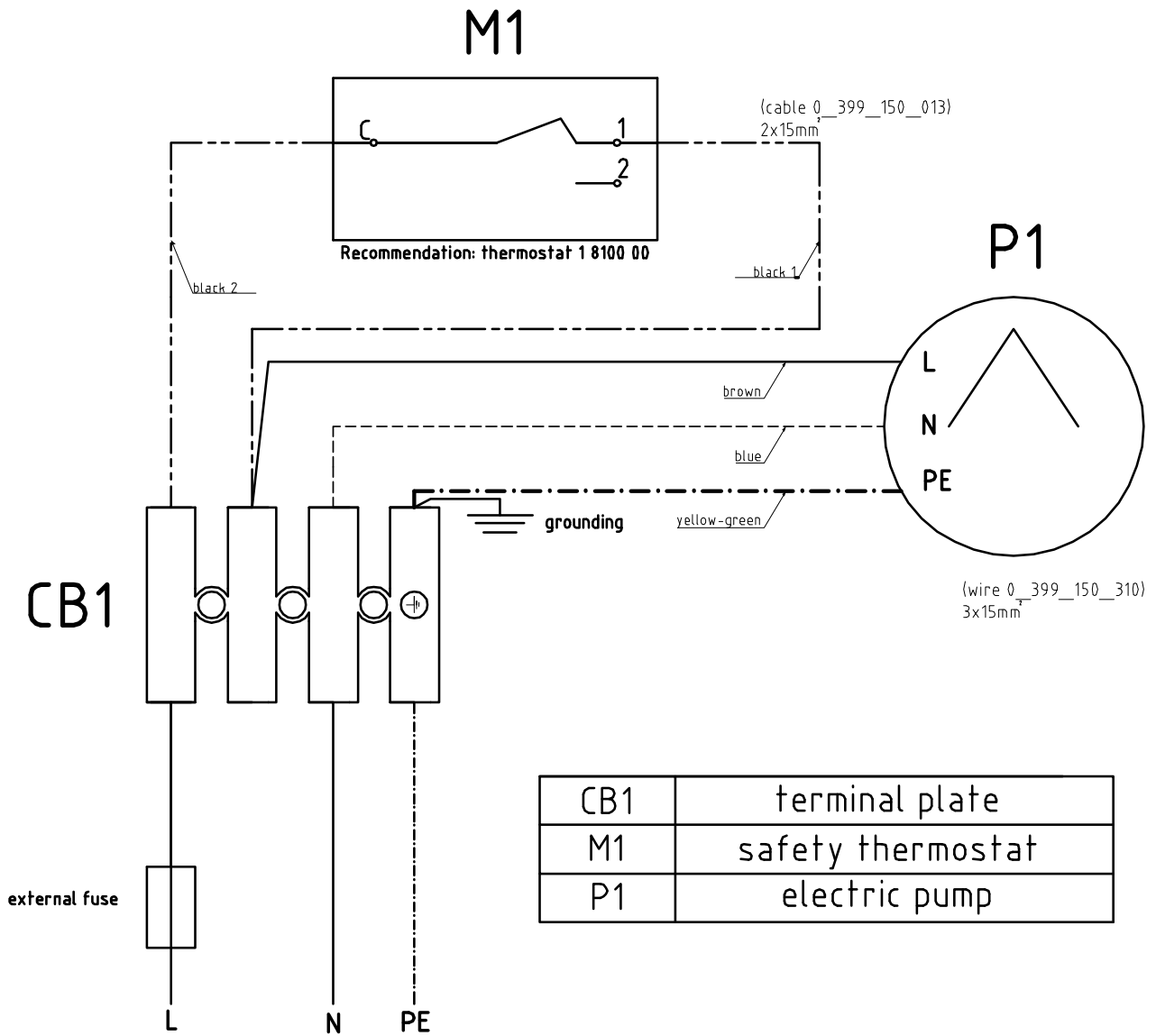

☑ Cable connection

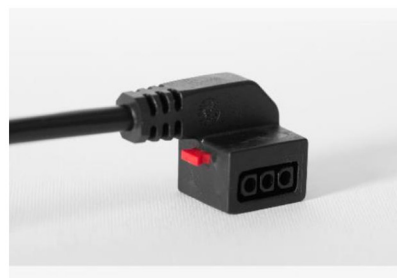



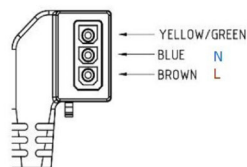



PR260

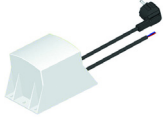

Power cable Facon PR260, FS 14

☑ Accessories

<p>Electronic Room Temperature Controller 1 change-over contact Set value range 10 – 30 °C. Switching difference ± 0.2 K fixed. 1 7790 15 (230V)</p>	
<p>Mechanical room thermostat, without timer, analogue setting of room temperature setpoint 5°C to 30°C, 230 V~, 50 Hz. Output: two or three contacts (changeover), 230 V~, 10 (3) A protection class IP 30. 3 F791 00</p>	
<p>Actuating drive 1 7708 53 230V NC incl. Adapter red 1 7708 52 24V NC incl. Adapter red</p>	
<p>Contact thermostat 1 8100 00</p>	
<p>Transformer 230V/24V 1 7796 04</p>	
<p>Power Input 230 V / 24V AC normally closed, 6-zone for COMPACTFLOOR. 3 F798 02</p>	

☑ Troubleshooting, malfunctions

Problem: Supply temperature too high on the secondary side

Solution:

- Thermostatic head with contact sensor defective or set to an incorrect target temperature
- Safety thermostat defective or set to an incorrect target temperature
- Check function of safety thermostat
- Check electrical connections against the electrical wiring diagram

Problem: Supply temperature too low on the secondary side

Solution:

- Check COMPACTFLOOR Light for trapped air and vent if necessary
- Thermostatic head is set to a target temperature that is too low

Problem: Flow rate too low / no flow

Solution:

- Check pump setting
- Check flowmeter presettings on the supply distribution manifold
- Check function of TS-90
- Check function of thermostatic inserts in the return distribution manifold

- Check function of thermal actuators on the return distribution manifold
- Check COMPACTFLOOR Light for trapped air and vent if necessary
- Choose lower pre-setting on RL-5

Problem: Flow rate too high / noise problems

Solution:

- Check pump setting
- Check flowmeter presettings on the supply distribution manifold
- Check COMPACTFLOOR Light for trapped air and vent if necessary

Decommissioning, drainage

If the COMPACTFLOOR Light is put out of operation for an extended time or disassembled for certain reasons then it must be decommissioned by closing all ball valves.

In rooms at risk of frost it is necessary to drain the COMPACTFLOOR Light before the onset of the colder seasons, if the COMPACTFLOOR Light is to be put out of operation for a number of days. To drain the control station put a vessel with a capacity of 4-8 litres under it and open the ball valve as long as the station will be completely empty of the water.

Note: by danger of frost the cold water lines connected to the loads and COMPACTFLOOR can also be frozen. Therefore it is recommended all the appliances and pipe lines up to the frost-proof parts to drain.

Maintenance and repairs

Thanks to its design, the COMPACTFLOOR Light is maintenance-free. However, the system may calcify with hard water. Depending on the hardness of the water, de-scaling should be performed by a specialist every one to two years. If calcification of the valves is excessive then these should be replaced immediately in order to ensure faultless functionality.

Recycling and disposal

Both the COMPACTFLOOR Light and the corresponding transport packaging largely consist of raw materials suitable for recycling.

Your COMPACTFLOOR Light and all accessories are not suitable for disposal with household waste. Ensure that your device and any available accessories are submitted for appropriate disposal.

Material

Pursuant to Article 33 of the REACH Regulation (EC No. 1907/2006), we are obliged to point out that the material lead is listed on the SVHC list and that all brass components manufactured in our products exceed 0.1 % (w / w) lead (CAS: 7439-92-1 / EINECS: 231-100-4). Since lead is a component part of an alloy, actual exposure is not possible and therefore no additional information on safe use is necessary.