

HERZ 4216

Regulating valve

Data sheet for 4216, Issue 1023

☑ Dimensions in mm

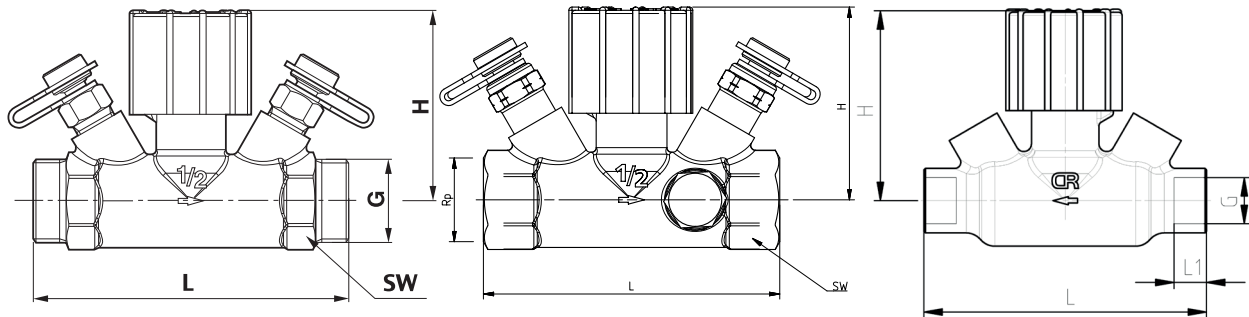

Order number	DN	Type	L	L1	Rp	G	SW	H	kvs
1 4216 21	15	Male thread	100	-	-	3/4		60 - 66	3,4
1 4216 22	20	Male thread	104	-	-	1		60 - 66	3,4
1 4216 31	15	Female thread	92	-	1/2		27	60 - 66	3,4
1 4216 32	20	Female thread	102	-	3/4		32	60 - 66	3,4
1 4216 11	15	Solder end	92	10	-	15		60 - 66	3,4
1 4216 12	20	Solder end	101	19	-	22		60 - 66	3,4

☑ Models

1 4216 2X Regulating valve, DN 15 and DN 20 straight model, presetting by limitation of valve lift, pipe connecting both sides with male thread cone G 3/4 or G 1, spindle seal by means of double-O-ring, 2 test points are mounted next to handwheel. Body made of dezincification resistant brass. Screw fittings have to be ordered separately

1 4216 3X Regulating valve, DN 15 and DN 20 straight model, presetting by limitation of valve lift, pipe connecting both sides with female thread Rp 1/2 or 3/4, spindle seal by means of double-O-ring, 2 test points are mounted next to handwheel. Body made of dezincification resistant brass. Drainage holes on both sides are closed with a drain plug 1/4". Screw fittings have to be ordered separately

1 4216 1X Regulating valve, DN 15 and DN 20 straight model, presetting by limitation of valve lift, pipe connecting both sides with solder connection, spindle seal by means of double-O-ring. Body made of dezincification resistant brass. Screw fittings have to be ordered separately.

☑ Test points

2 test points are located adjacent to the hand wheel at identical angles, sealed by the manufacturer. This arrangement permits optimum access and connection of measuring instruments in any position of installation.

☑ Field of Application

For hydraulic balancing in heating and cooling systems, adjustment of distribution mains, circuits, heat exchangers, heating and cooling registers, etc. Close the valve clockwise.

☑ Flow Direction

During installation, take into account the flow direction arrow on the valve body.

☑ Installation Position

The valve spindle arranged perpendicular to the valve axis guarantees optimum accessibility and optimum valve operation in any installation position.

Other models

4017 M	DN 15–50	STRÖMAX, Circuit regulating valve with test points for differential pressure measurement, straight model, kvs = 0,46 - 33,00 m ³ /h
4017 ML	DN 15–50	STRÖMAX, Circuit regulating valve with test points for differential pressure measurement and capillary connection, straight model, kvs = 0,46 - 33,00 m ³ /h
4017 R	DN 15–50	STRÖMAX, Circuit regulating valve without test points, straight model, kvs = 0,46 - 33,00 m ³ /h
4217 GM	DN 15–80	STRÖMAX-Circuit regulating valve, straight model, with test points, non-rising handwheel digital display of the presetting in handwheel, kvs = 0,93 - 76,1 m ³ /h
4217 GML	DN 15–80	STRÖMAX-Circuit regulating valve, straight model, with test points and capillary connection, non-rising handwheel digital display of the presetting in handwheel, kvs = 0,93 - 76,1 m ³ /h
4217 GR	DN 15–80	STRÖMAX-Circuit regulating valve, straight model, without test points, non-rising handwheel digital display of the presetting in handwheel, kvs = 0,93 - 76,1 m ³ /h
4217GN	DN15-50	STRÖMAX-GN, commissioning valve, straight model, with test points for differential pressure measurement, kvs = 1,76 - 17,16 m ³ /h

Technical data

Max. operating temperature	130 °C
Min. operating temperature	-20 °C (water 2 °C)
Max. operating pressure	10 bar

Water purity in accordance with the OENORM H5195 and VDI 2035 standards.

Ethylene and propylene glycol can be mixed to a ratio of 25 - 50 vol. %.

HERZ compression adapters for copper and steel pipes, allowable temperature and pressure ratings according to EN 1254-2 1998 Table 5.

HERZ plastic pipe connections max. operating temperature 95 °C and max. operating pressure 10 bar, if approved by the pipe manufacturer.

Ammonia contained in hemp can damage brass valve bodies, EPDM gaskets can be affected by Mineral oils lubricants and thus lead to failure of the EPDM seals. Please refer to manufacturers documentation when using ethylene glycol products for frost and corrosion protection.

Material and construction

Body and spindle	brass
Hand wheel	Polyamide, red
Spindle seals	EPDM
Internal threaded connectors	acc. ISO 7/1

Plastic pipe connection

The circuit regulating valves can be used in equipment with plastic pipes. Adapters and plastic pipe connections can be fitted. Models, dimensions and fittings are to be found in the HERZ brochure.

Copper and soft steel pipes

With the installation of soft steel or copper pipes with a compression adapter, we recommend the use the support sleeves. To ensure the proper installation of compression adapters, the thread of the sealing ring or the nut and the sealing ring itself can be coated with silicone oil. We refer to our instructions.

Connection spare parts

1 **6274** XX 8 - 16 mm Compression adapter metallic seal. Suitable for soft steel and copper pipes.

Not suitable for stainless steel pipes and chrome-plated metal pipes.

1 **6276** XX 12 - 18 mm Compression adapter. Only suitable for copper pipes.

Not suitable for chrome-plated metal pipes, soft steel pipes or stainless steel pipes.

1 **6098** XX 10 - 20 mm Plastic pipe connections G 3/4 for PE-RT, PE-X, PB and aluminium composite pipes

1 **6273** 01 22 mm Compression adapter G1", metallic seal. Suitable for soft steel and copper pipes

1 **6198** XX 16 - 26 mm Plastic pipe connections G 1" for PE-RT, PE-X, PB and aluminium composite pipes

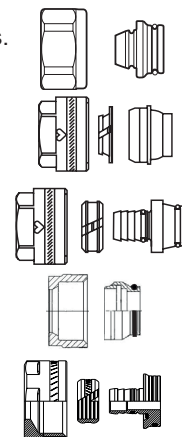

HERZ „PipeFix“ System

Press fittings and aluminium composite pipes DN 10 - DN 75

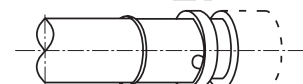

☑ Spare parts and accessories

1 0284 01	¼	Test points for circuit regulating valves, blue cap (return) for flow computer
1 0284 02	¼	Test points for circuit regulating valves, red cap (flow) for flow computer.
1 0284 11	¼	Test points for circuit regulating valves, blue cap (return) for flow computer, Extended model for insulated valves up to 40 mm.
1 0284 12	¼	Test points for circuit regulating valves, brass version, red cap (flow) for flow computer. Extended model for insulated valves up to 40 mm.
1 0284 22	¼	Test points with draining function, brass version, red cap (flow) for Herz-Measuring computer.
1 0284 21	¼	Test points with draining function, brass version, blue cap (return) for Herz-Measuring computer.
1 0284 23	¼	Long quick test point with drain valve, straight, blue
1 0284 24	¼	Long quick test point with drain valve, straight, red
1 0276 09	¼	Draining valve with handle und swiveling hose connection, brass version, hose connection 1 6206 01 must be ordered separately.
2 0273 09	¼	Sealing screw, brass version, dezincification-resistant brass with O-ring seal and external hex.
1 8900 05		HerzCOMP 650 measuring computer

☑ HERZ screw connections

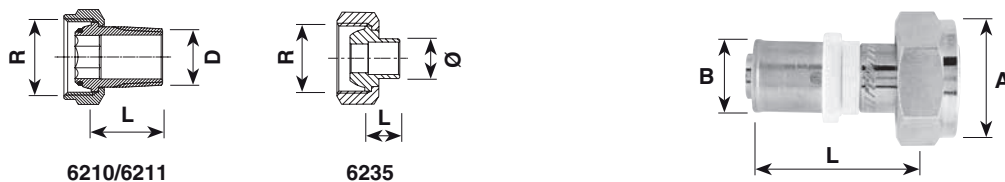

Valve dimension	Order number	R	C	ø	L
DN 15	1 6210 21	3/4	1/2	–	25
DN 15	1 6210 26	3/4	1/2	–	21
DN 15	1 6210 11	3/4	1/2	–	30
DN 15	1 6211 00	3/4	3/8	–	24
DN 15	1 6235 21	3/4	–	12	13
DN 15	1 6235 31	3/4	–	15	13
DN 15	1 6235 41	3/4	–	18	18

Valve dimension	Order number	A	B	L
DN 15	P 7014 81	G 3/4	14 x 2	50
DN 15	P 7016 81	G 3/4	16 x 2	50
DN 15	P 7018 81	G 3/4	18 x 2	50
DN 15	P 7020 81	G 3/4	20 x 2	50

☑ Application

Can be used as isolating and commissioning valve.

☑ Installation

The HERZ STRÖMAX 4216 valve is installed in the flow or return with the flow in the direction of the arrow on the casing. The installation location should be taken into account.

☑ Tips

When installing HERZ STRÖMAX 4216 for solar installations please screw out the upper part in order to prevent the damages during soldering of the seals. Before commissioning in order to use in solar systems, the handwheel is to be removed as it can melt at higher temperatures.

☑ Mounting 4216 for solar installations

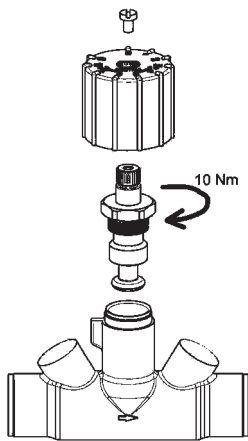

Remove the handwheel from the valve body.
 Solder the valve body into the pipework using solder type 95/5 (95% tin, 5% antimony or silver) ensuring the direction of flow arrow on the body is coincident with the flow direction.
 Refit the stem complete with O-ring seals into the body.
 Refit the stem retaining nut. (A thread Loctite may be used).
 Rotate the handwheel to the closed position (clockwise) and fit with the zero position.
 Adjust the handwheel at any desired position.
 Remove fastening screw and pull it off.
 Fit the cap onto the valve stem depending on the desired position.
 Rotate the handwheel to the desired position and re-install fastening screw.

☑ Application example: STRÖMAX 4216 in solar systems

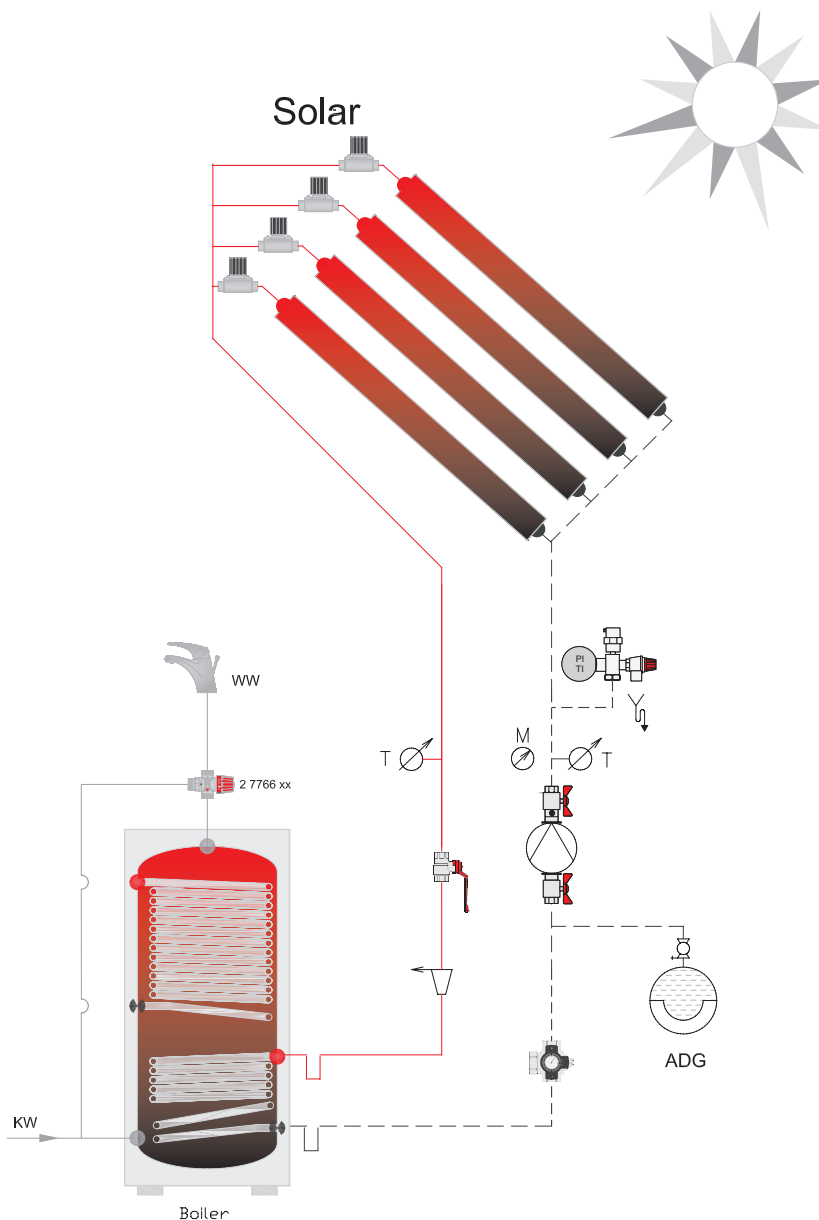

☑ Application example: STRÖMAX 4216 for heating and cooling

Pos.	Order numbers	Description
1	1 4218 80-88	Strömmax GF
2	1 4111 83-85	Strainer
3	1 4216 xx	Regulating valve
4	1 4115 xx	Shutoff valve
5	1 4002 41-46	Differential pressure controller
6	1 4217 01-08	Strömmax GM
7	1 7763 50-62	Four-port control valves with bypass
8	1 7762 50-62	Three-port control valves
9	1 7990 31 + 1 7708 98	Actuating drive for continuous control + adapter M30x1,5
10	3 F799 18	Electronic room thermostat with display incl. cooling
11	1 7708 53 + 1 7708 90	Actuating drive for 2-point control + adapter M28x1,5
12	3 F791 00	Mechanical room thermostat
13	1 4037 15-50	3-port mixing and diverting valve
14	1 7712 11	Valve drive with position controller for 3-port valves, 500 N
17	1 7217 51-52	Control and regulating valve
18	3 F799 17	Electronic room thermostat with display incl. cooling
19	1 2100 00-09	Ball valve
20	1 4006 XX	PICV
21	1 4004 31-32	Differential pressure overflow valve
22	1 4017 01-21	Commissioning valve with integral orifice
23	1 7760 01-21	Thermostatic valve
24	1 7708 52-53+1 7708 98	Actuating drive for 2-point control+ adapter M30x1,5
25	1 4219 01-09	Butterfly valve

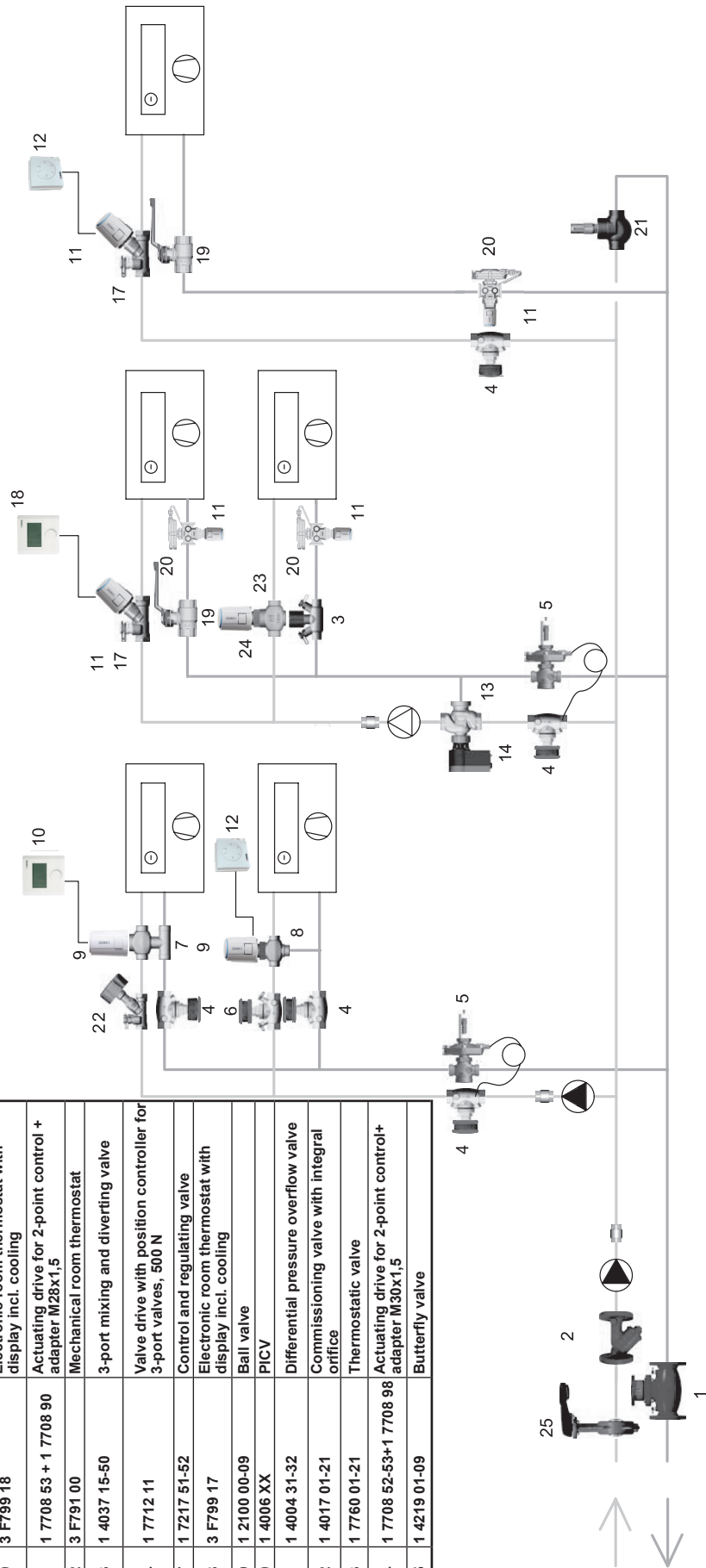

Adjustment implementation

The adjustment is made by fixing at a specific value or blocking the rotational movement from being fully opened or completely close - in cases, when the minimum flow rate is required.

1. Adjust the valve to the desired position of the handwheel.
2. Remove fastening screw and pull it off.
3. Fit the cap onto the valve stem depending on the desired position.
4. Rotate the handwheel to the desired position and re-install fastening screw.



Picture:
Adjustment scale on the handwheel



Picture:
Handwheel positioning screw



Picture:
Nose at the valve
Groove at the handwheel

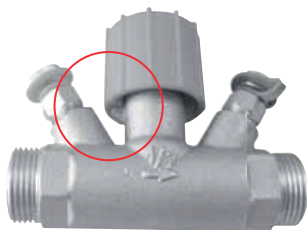

Picture:
Fixed position

Measuring

To maintain meaningful measurement results, it is important to observe the calming distances in the inlet and outlet. According to CIBSE Code W double regulating valves must always be installed with a minimum of 5 pipe diameters of straight pipe, without intrusion, upstream of the valve. Downstream of the valve a minimum of 2 pipe diameters of straight pipe are required. If a pump is installed directly before the valve, we recommend 10 pipe diameters of straight pipe, without intrusion, upstream of the valve.

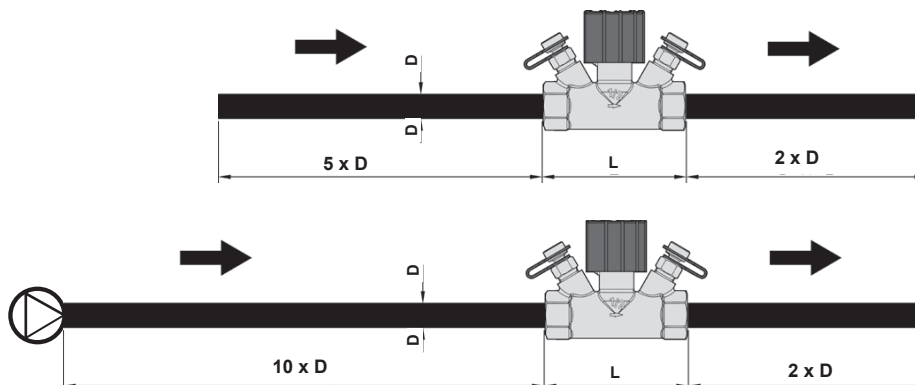

☑ Brass

Pursuant to Article 33 of the REACH Regulation (EC No. 1907/2006), we are obliged to point out that the material lead is listed on the SVHC list and that all brass components manufactured in our products exceed 0.1% (w / w) lead (CAS: 7439-92-1 / EINECS: 231-100-4). Since lead is a component part of an alloy, actual exposure is not possible and therefore no additional information on safe use is necessary

☑ Disposal

The disposal of HERZ regulating valves must not endanger the health or the environment. National legal regulations for proper disposal of the HERZ regulating valves have to be followed.

Please note: all diagrams are indicative in nature and do not claim to be complete.

All specifications and statements within this document are according to information available at the time of printing and meant for informational purpose only. Herz Armaturen reserves the right to modify and change products as well as its technical specifications and/or its functioning according to technological progress and requirements. It is understood that all images of Herz products are symbolic representations and therefore may visually differ from the actual product. Colours may differ due to printing technology used. In case of any further questions don't hesitate to contact your closest HERZ Branch-office.

