

HERZ-Actuators

for HERZ Combi Valves and Control Valves

Data sheet for Actuators 7712, Issue 1222

☑ Dimensions for actuator, continuous, 24V [mm]

F 7712 90, F 7712 91

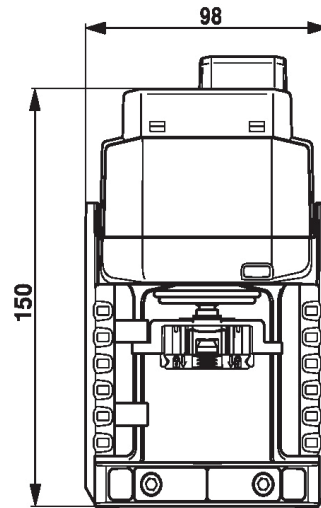
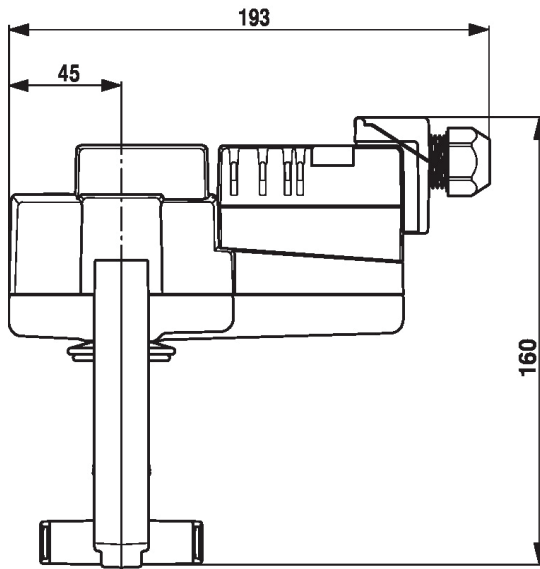

F 7712 92

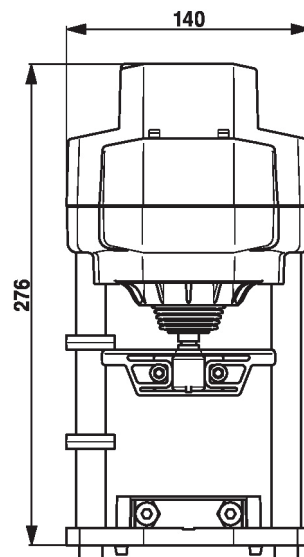
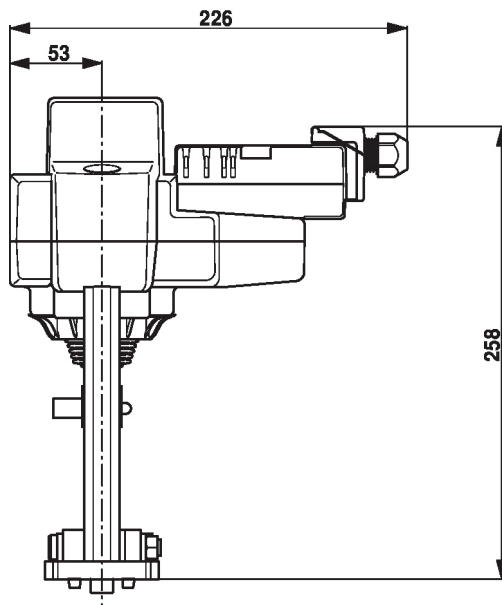

Technical data

Modulating		F 7712 90	F 7712 91	F 7712 92
Electrical data	Nominal voltage	AC/DC 24 V		
	Nominal voltage frequency	50/60 Hz		
	Nominal voltage range	AC 19.2 V...28.8 V / DC 21.6 V...28.8 V		
	Power consumption in operation	1 W	1.5 W	4 W
	Power consumption in rest position	0.5 W	0.5 W	1.5 W
	Power consumption for wire sizing	2 VA	3 VA	6 VA
	Connection supply / control	Terminals with cable 1 m, 4 x 0.75 mm ² (Terminal 4 mm ²)		
	Parallel operation	Yes (note the performance data)		
Functional data	Actuating force motor	500 N	1000 N	2500 N
	Characteristic graph	linear		
	Operating range Y	2 V...10 V		
	Input impedance	100 kΩ		
	Position feedback U	2 V...10 V		
	Position feedback U note	max. 0.5 mA		
	Position accuracy	±5%		
	Manual override	with push-button, can be locked		
	Stroke	15 mm	20 mm	40 mm
	Running time motor	150 s / 15 mm	150 s / 20 mm	150 s / 40 mm
	Adaptation setting range	manual (automatic on first power-up)		
	Sound power level, motor	45 dB (A)	45 dB (A)	55 dB (A)
	Position indication	Mechanically, 5...15 mm stroke	Mechanically, 5...20 mm stroke	Mechanically, 5...40 mm stroke
	Safety data	Protection class IEC/EN	III, Safety Extra-Low Voltage (SELV)	
Power source UL		Class 2 Supply		
Degree of protection IEC/EN		IP54		
Degree of protection NEMA/UL		NEMA 2		
Enclosure		UL Enclosure Type 2		
EMC		CE according to 2014/30/EG		
Certification IEC/EN		IEC/EN 60730-1 and IEC/EN 60730-2-14		
UL Approval		cULus according to UL60730-1A, UL60730-2-14 and CAN/CSA E60730-1 The UL marking on the actuator depends on the production site, the device is UL-compliant in any case		
Mode of operation		Type 1		
Rated impulse voltage supply / control		0.8 kV		
Pollution degree		3		
Ambient temperature		0 °C ... 50 °C [32...122 °F]		
Storage temperature		-40 °C ... 80 °C [-40...176 °F]		
Ambient humidity		max. 95% RH, non-condensing		
Servicing	maintenance-free			
kg	Weight ~	1,1 kg	1,1 kg	3,6 kg

☑ Dimensions for actuator, open-close, 3-point, 24V [mm]

F 7712 95, F 7712 96

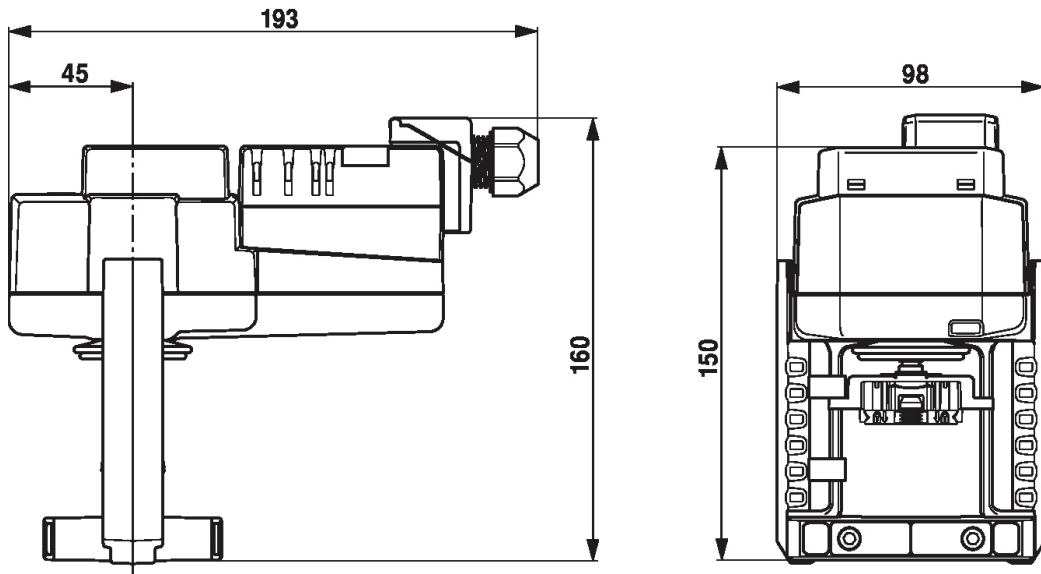

F 7712 98

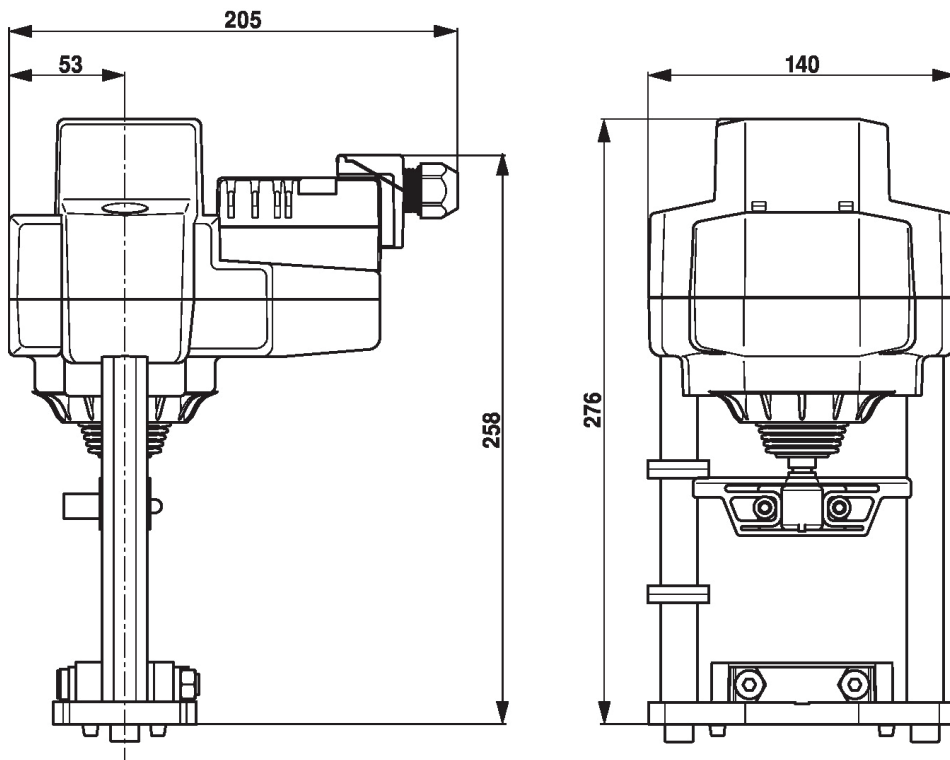

☑ Technical data

Open-close, 3-point		F 7712 95	F 7712 96	F 7712 98
Electrical data	Nominal voltage	AC/DC 24 V		
	Nominal voltage frequency	50/60 Hz		
	Nominal voltage range	AC 19.2 V...28.8 V / DC 21.6 V...28.8 V		
	Power consumption in operation	1 W	1.5 W	2.5 W
	Power consumption in rest position	0.5 W		
	Power consumption for wire sizing	1 VA	3 VA	4.5 VA
	Connection supply / control	Terminals with cable 1 m, 4 x 0.75 mm ² (Terminal 4 mm ²)		
	Parallel operation	Yes (note the performance data)		
Functional data	Actuating force motor	500 N	1000 N	2500 N
	Manual override	with push-button, can be locked		
	Stroke	15 mm	20 mm	40 mm
	Running time motor	150 s / 15 mm	150 s / 20 mm	150 s / 40 mm
	Sound power level, motor	45 dB (A)	45 dB (A)	56 dB (A)
	Position indication	Mechanically, 5...15 mm stroke	Mechanically, 5...20 mm stroke	Mechanically, 5...40 mm stroke
Safety data	Protection class IEC/EN	III, Safety Extra-Low Voltage (SELV)		
	Power source UL	Class 2 Supply		
	Degree of protection IEC/EN	IP54		
	Degree of protection NEMA/UL	NEMA 2		
	Enclosure	UL Enclosure Type 2		
	EMC	CE according to 2014/30/EG		
	Certification IEC/EN	IEC/EN 60730-1 and IEC/EN 60730-2-14		
	UL Approval	cULus according to UL60730-1A, UL60730-2-14 and CAN/CSA E60730-1 The UL marking on the actuator depends on the production site, the device is UL-compliant in any case		
	Mode of operation	Type 1		
	Rated impulse voltage supply / control	0.8 kV		
	Pollution degree	3		
	Ambient temperature	0 °C ... 50 °C [32...122°F]		
	Storage temperature	-40 °C ... 80 °C [-40...176°F]		
Ambient humidity	Max. 95% RH, non-condensing			
Servicing	maintenance-free			
kg	Weight ~	1.1 kg	1.1 kg	3.6 kg

☑Dimensions for actuator, open-close, 3-point, 100...240 V [mm]

F 7712 81, F 7712 82

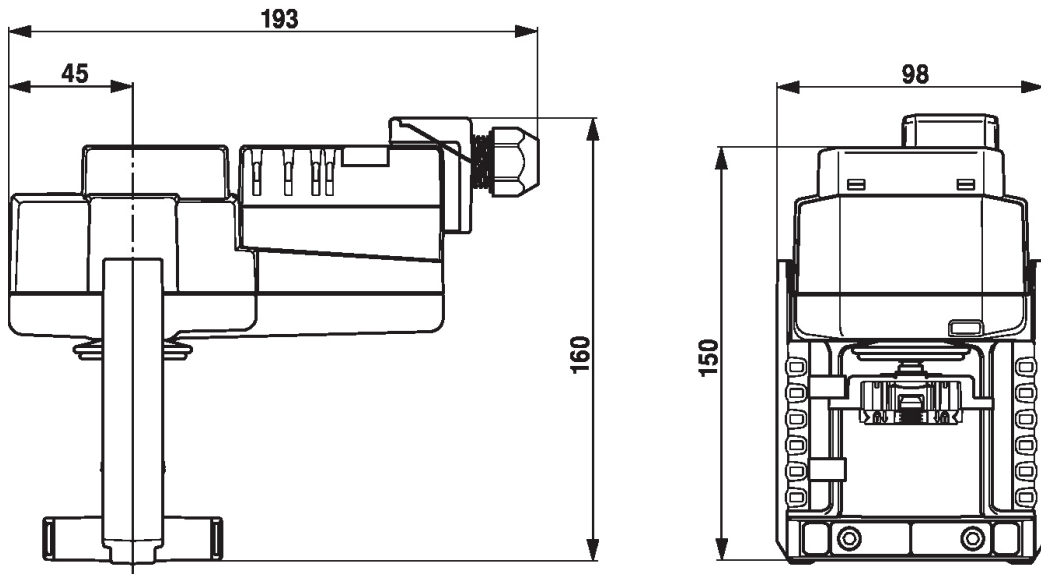

F 7712 84

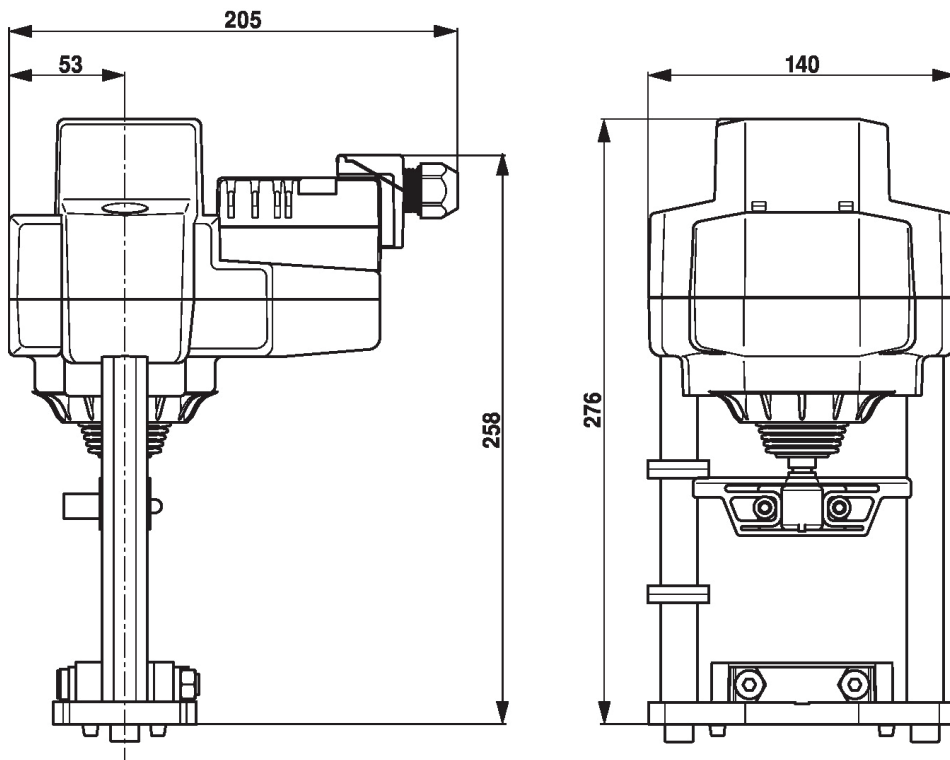

☑ Technical data

Open-close, 3-point		F 7712 81	F 7712 82	F 7712 84
Electrical data	Nominal voltage	AC 100...240 V		
	Nominal voltage frequency	50/60 Hz		
	Nominal voltage range	AC 85...265 V		
	Power consumption in operation	2 W	2 W	5.5 W
	Power consumption in rest position	1 W	1 W	1 W
	Power consumption for wire sizing	4 VA	4.5 VA	9.5 VA
	Connection supply / control	Terminals with cable 1 m, 4 x 0.75 mm ² (Terminal 4 mm ²)		
	Parallel operation	Yes (note the performance data)		
Functional data	Actuating force motor	500 N	1000 N	2500 N
	Manual override	with push-button, can be locked		
	Stroke	15 mm	20 mm	40 mm
	Running time motor	150 s / 15 mm	150 s / 20 mm	150 s / 40 mm
	Sound power level, motor	45 dB (A)	45 dB (A)	56 dB (A)
	Position indication	Mechanically, 5...15 mm stroke	Mechanically, 5...20 mm stroke	Mechanically, 5...40 mm stroke
Safety data	Protection class IEC/EN	II, reinforced insulation		
	Power source UL	Class 2 Supply		
	Degree of protection IEC/EN	IP54		
	Degree of protection NEMA/UL	NEMA 2		
	Enclosure	UL Enclosure Type 2		
	EMC	CE according to 2014/30/EG		
	Low voltage directive	CE according to 2014/35/EG		
	Certification IEC/EN	IEC/EN 60730-1 and IEC/EN 60730-2-14		
	UL Approval	cULus according to UL60730-1A, UL60730-2-14 and CAN/CSA E60730-1 The UL marking on the actuator depends on the production site, the device is UL-compliant in any case		
	Mode of operation	Type 1		
	Rated impulse voltage supply / control	4 kV		
	Pollution degree	3		
	Ambient temperature	0 °C ... 50 °C [32...122°F]		
	Storage temperature	-40 °C ... 80 °C [-40...176°F]		
Ambient humidity	Max. 95% RH, non-condensing			
Servicing	maintenance-free			
kg	Weight ~	1,1 kg	1,1 kg	3,6 kg

Mode of operation

Actuators F 7712 90, 91, 92

The actuator is connected with a standard control signal of 0...10 V and drives to the position defined by the control signal. The measuring voltage U serves for the electrical display of the actuator position 0.5...100% and as control signal for other actuators.

Simple direct mounting

Simple direct mounting on the globe valve by means of form-fit hollow clamping jaws. The actuator can be rotated by 360° on the valve neck.

Manual override

Actuators F 7712 90, 91, 92; F 7712 95, 96, 98 and F 7712 81, 82, 84

Manual override with push-button possible (the gear train is disengaged for as long as the button is pressed or remains locked).

The stroke can be adjusted by using a hexagon socket screw key (5 mm), which is inserted into the top of the actuator. The stem extends when the key is rotated clockwise.

High functional reliability

The actuator is overload protected, requires no limit switches and automatically stops when the end stop is reached.

Home position

Actuators F 7712 95, 96, 98 and F 7712 81, 82, 84

Factory setting: Actuator stem is retracted.

Actuators F 7712 90, 91, 92

Factory setting: Actuator stem is retracted.

The first time the supply voltage is switched on, i.e. at the time of commissioning, the actuator carries out an adaptation, which is when the operating range and position feedback adjust themselves to the mechanical setting range. The actuator then moves into the position defined by the control signal.

Adaptation and synchronisation

Actuators F 7712 90, 91, 92

An adaptation can be triggered manually by pressing the "Adaptation" button. Both mechanical end stops are detected during the adaptation (entire setting range).

The actuator then moves into the position defined by the control signal.

Setting direction of motion

When actuated, the stroke direction switch changes the running direction in normal operation.

Restriction 3-point controller

Actuators F 7712 95, 96, 98 and F 7712 81, 82, 84

It must be ensured that the pulsating 3-point controller stops when the end position is reached. If this is not possible on the system side, the multifunctional 24 V version of the actuator must be used.

Electrical accessories

Auxiliary switch 2 x SPDT add-on S2A-H

Electrical installation

Actuators F 7712 81, 82, 84



Caution: Power supply voltage!

Parallel connection of other actuators possible. Observe the performance data.

Direction of stroke switch factory setting: Actuator stem retracted (▲).

Actuators F 7712 90, 91, 92, 95, 96, 98



Supply from isolating transformer.

Parallel connection of other actuators possible. Observe the performance data.

Direction of stroke switch factory setting: Actuator stem retracted (▲).

Wiring diagrams

Actuators F 7712 90, 91, 92

AC/DC 24 V, modulating

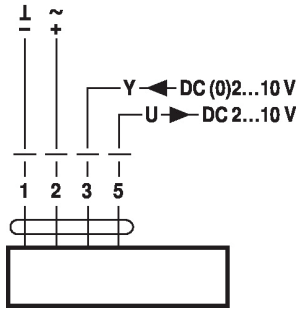

Cable colours:

- 1 = black
- 2 = red
- 3 = white
- 5 = orange

Override control (frost protection circuit)

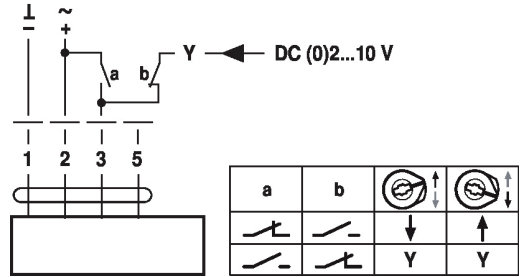

Actuators F 7712 95, 96, 98

AC/DC 24 V, open/close

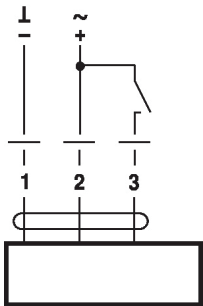

Cable colours:

- 1 = black
- 2 = red
- 3 = white

AC/DC 24 V, 3-point

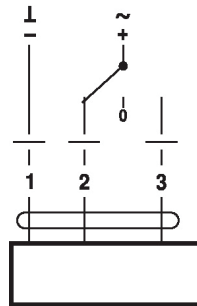

Cable colours:

- 1 = black
- 2 = red
- 3 = white

Actuators F 7712 81, 82, 84

AC 230 V, open/close

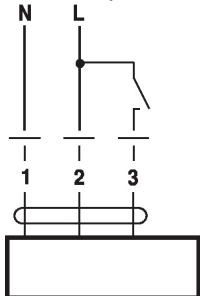

Cable colours:

- 1 = blue
- 2 = brown
- 3 = white

AC 230 V, 3-point

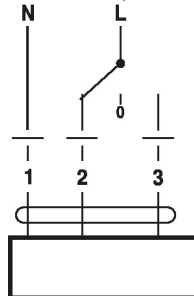

Cable colours:

- 1 = blue
- 2 = brown
- 3 = white

☑ Operating controls and indicators

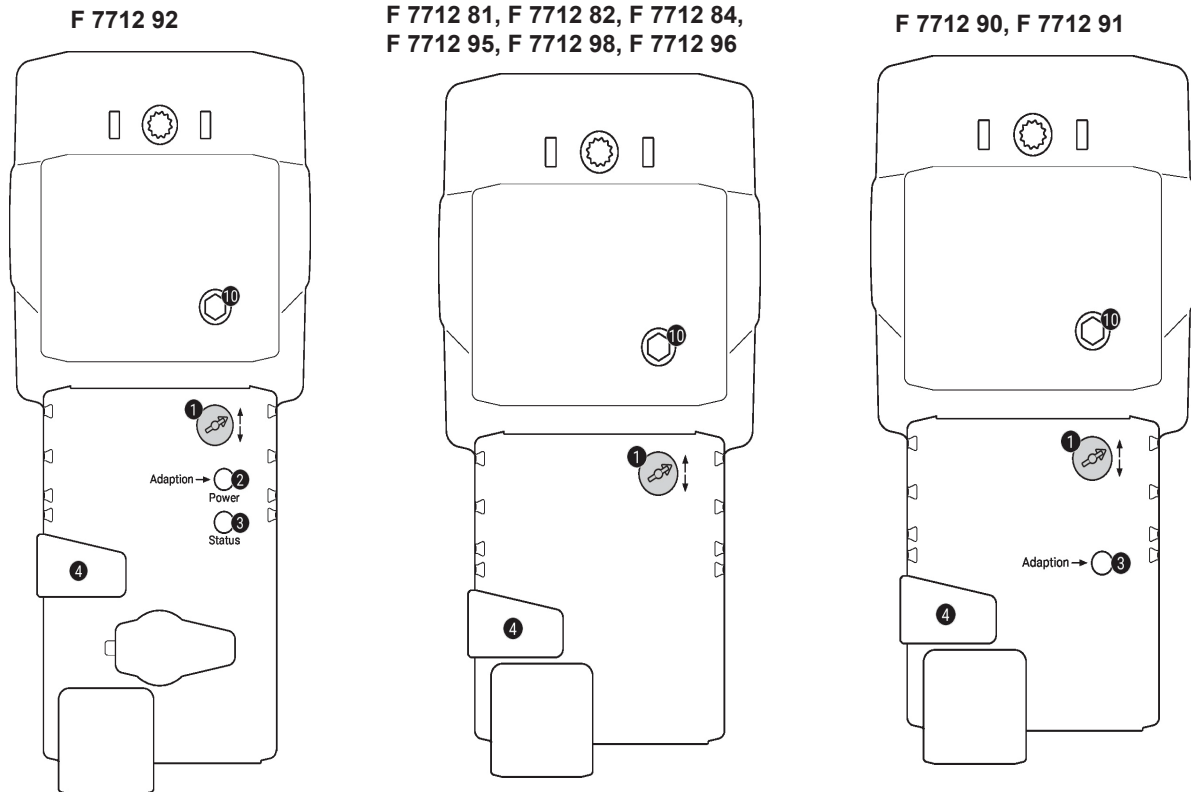

- 1 Direction of stroke switch**
Switch over: Direction of stroke changes
- 2 Push-button and LED display green**
Off: No power supply or malfunction
On: In operation
Press button: Triggers stroke adaptation, followed by standard mode
- 3 Push-button and LED display yellow**
Off: Standard mode
On: Adaptation or synchronisation process active
Press button: No function
- 4 Manual override button**
Press button: Gear train disengages, motor stops, manual override possible
Release button: Gear train engages, standard mode
- 10 Manual override**
Clockwise: Actuator stem extends
Counterclockwise: Actuator stem retracts

☑ Disposal notice

The disposal of HERZ actuators must not endanger the health or the environment. National legal regulations for proper disposal of the HERZ actuators have to be followed.

☑ Assembling valve with actuators F 7712 90, F 7712 91; F 7712 95, F 7712 96 and F 7712 81, F 7712 82

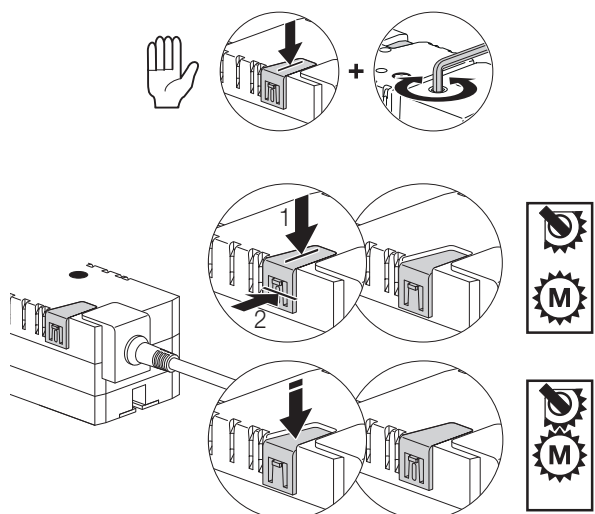
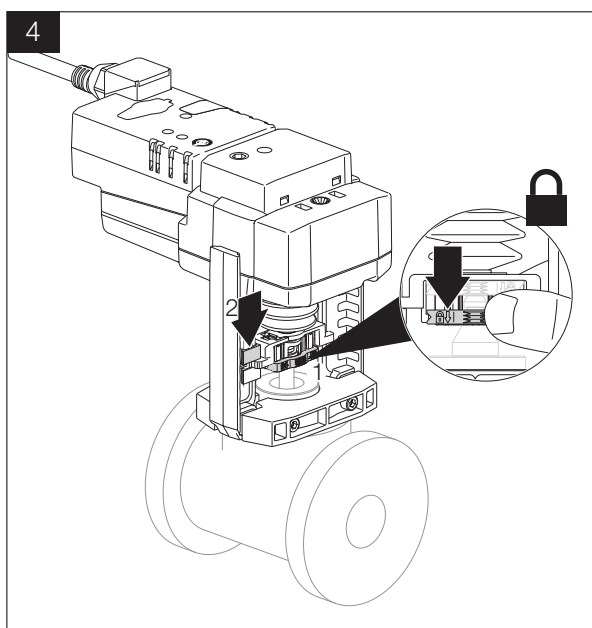
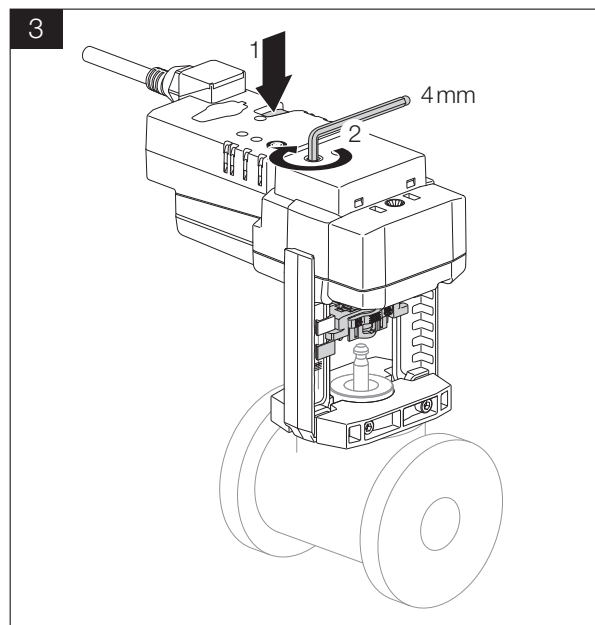
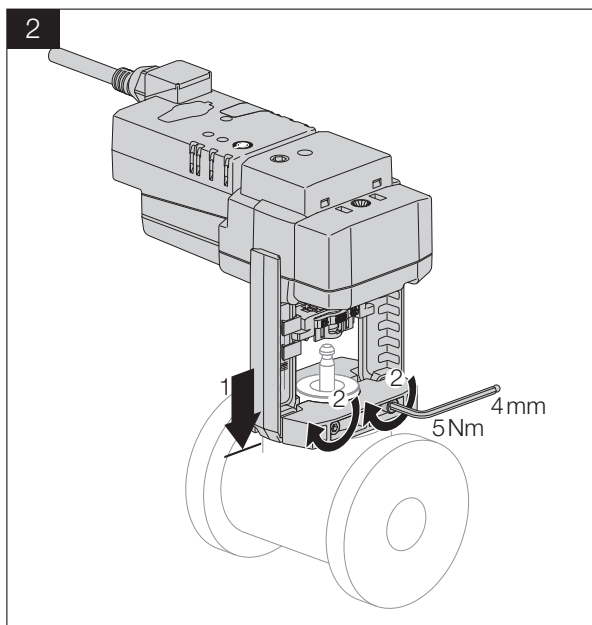
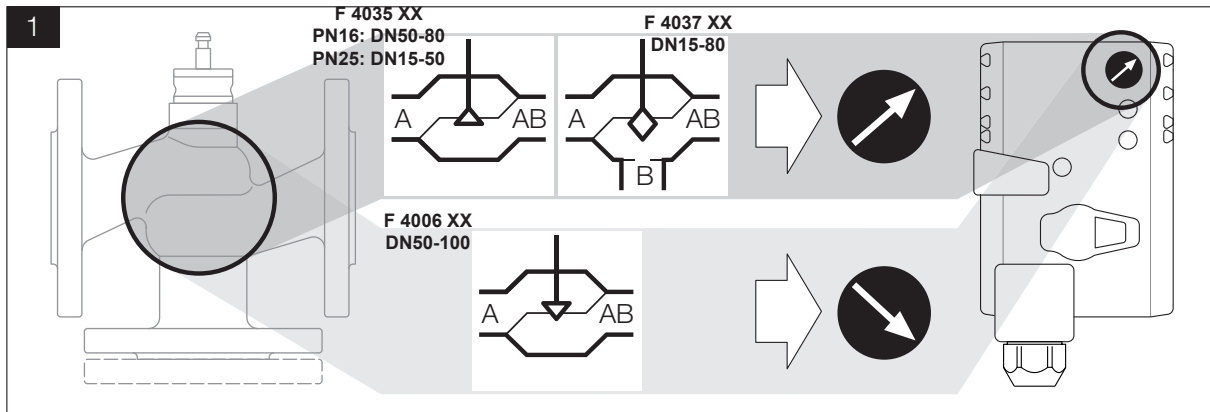

☑ Assembling valve with actuators F 7712 92, F 7712 98 and F 7712 84

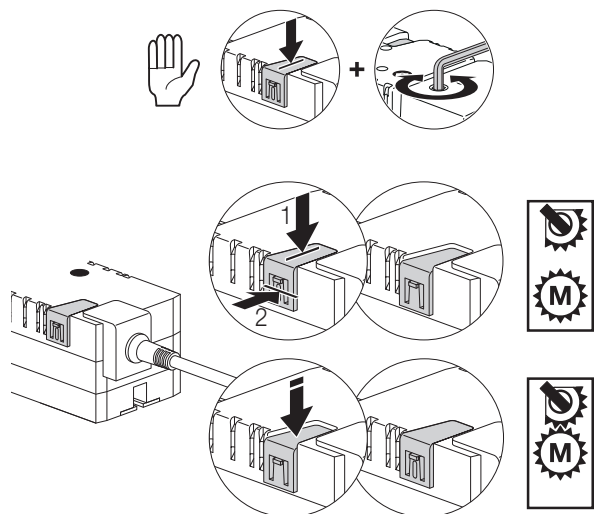
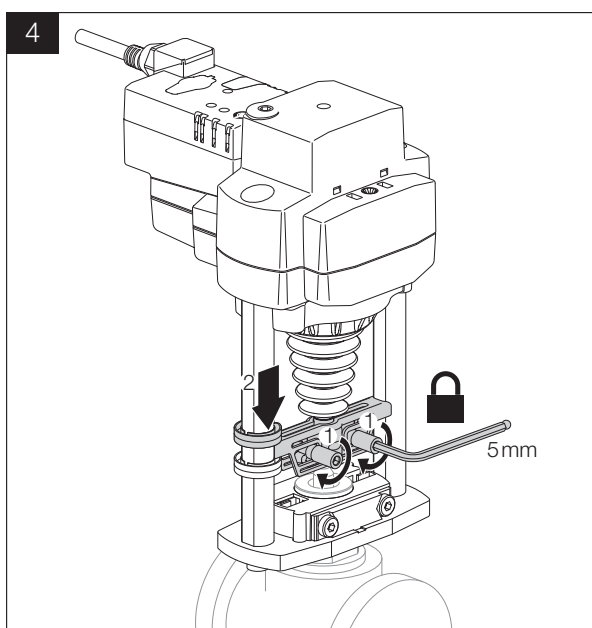
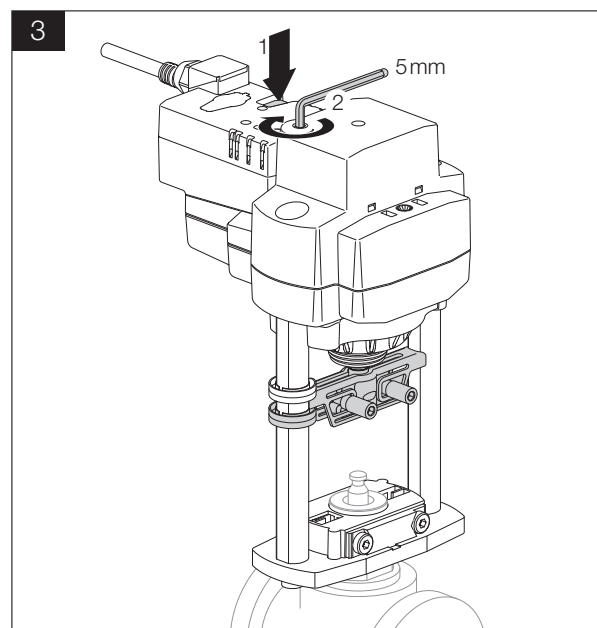
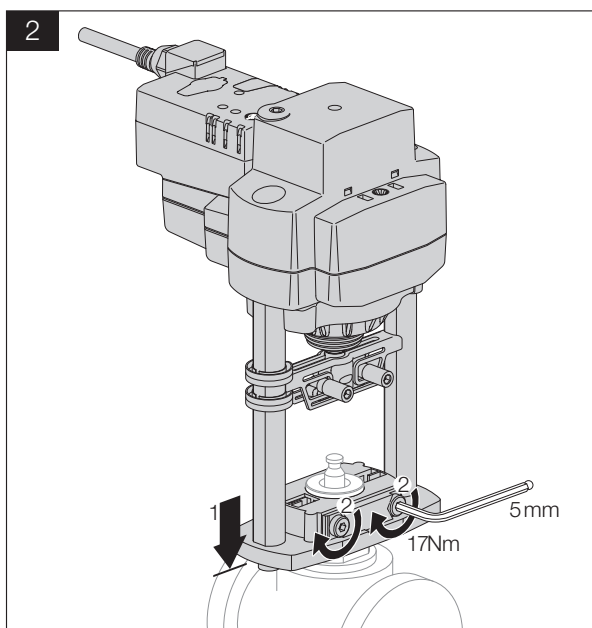
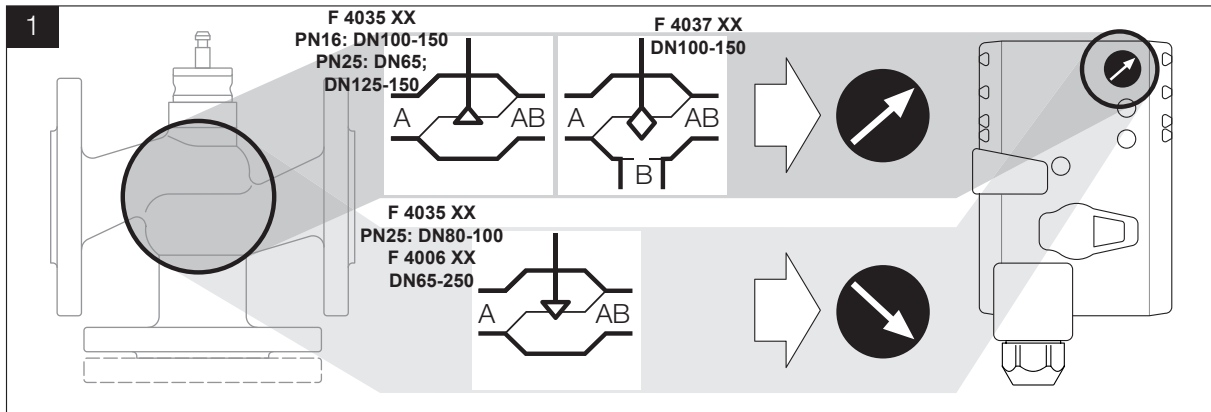

Actuator selection for HERZ valves

Order number voltage / control / force / stroke			F 7712 90 24V, 2-10V 500N, 15mm	F 7712 91 24V, 2-10V 1000N, 20mm	F 7712 92 24V, 2-10V 2500N, 40mm	F 7712 95 24V on-off, 3 Pkt. 500N, 15mm	F 7712 96 24V on-off, 3 Pkt. 1000N, 20mm	F 7712 98 24V on-off, 3 Pkt. 2500N, 40mm	F 7712 81 230V on-off, 3 Pkt. 500N, 15mm	F 7712 82 230V on- off, 3 Pkt. 1000N, 20mm	F 7712 84 230V on- off, 3 Pkt. 2500N, 40mm
Combi valve	DN	kvs									
F 4006 71	15	2,5	+			+			+		
F 4006 90	15	2,5	+			+			+		
F 4006 72	15	4	+			+			+		
F 4006 91	15	4	+			+			+		
F 4006 73	25	6,3	+			+			+		
F 4006 92	25	6,3	+			+			+		
F 4006 93	25	8	+			+			+		
F 4006 53	25	8	+			+			+		
F 4006 74	32	12	+			+			+		
F 4006 94	32	12	+			+			+		
F 4006 75	40	20	+			+			+		
F 4006 95	40	20	+			+			+		
F 4006 80	50	32	+			+			+		
F 4006 96	50	32	+			+			+		
F 4006 81	65	50			+			+			+
F 4006 97	65	50			+			+			+
F 4006 82	80	80			+			+			+
F 4006 98	80	80			+			+			+
F 4006 83	100	125			+			+			+
F 4006 99	100	125			+			+			+
F 4006 84	125	180			+			+			+
F 4006 10	125	180			+			+			+
Combi valve	DN	kvs									
F 4006 62	50		+			+			+		
F 4006 63	65		+			+			+		
F 4006 64	80			+			+			+	
F 4006 65	100			+			+			+	
F 4006 66	125				+			+			+
F 4006 56	125 HF				+			+			+
F 4006 67	150				+			+			+
F 4006 57	150 HF				+			+			+
F 4006 68	200 SF				+			+			+
F 4006 58	200 HF				+			+			+
F 4006 48	200UHF				+			+			+
F 4006 69	250 SF				+			+			+
F 4006 59	250 HF				+			+			+
2-port valves											
F 4035 01	15	1	+			+			+		
F 4035 40	15	1	+			+			+		
F 4035 11	15	1,6	+			+			+		
F 4035 51	15	1,6	+			+			+		
F 4035 21	15	2,5	+			+			+		
F 4035 61	15	2,5	+			+			+		
F 4035 31	15	4	+			+			+		
F 4035 71	15	4	+			+			+		
F 4035 03	25	6,3	+			+			+		

Order number voltage / control / force / stroke			F 7712 90 24V, 2-10V 500N, 15mm	F 7712 91 24V, 2-10V 1000N, 20mm	F 7712 92 24V, 2-10V 2500N, 40mm	F 7712 95 24V on-off, 3 point, 500N, 15mm	F 7712 96 24V on-off, 3 point, 1000N, 20mm	F 7712 98 24V on-off, 3 point, 2500N, 40mm	F 7712 81 230V on- off, 3 point, 500N, 15mm	F 7712 82 230V on- off, 3 point, 1000N, 20mm	F 7712 84 230V on- off, 3 p., 2500N, 40mm
F 4035 43	25	6,3	+			+			+		
F 4035 13	25	10	+			+			+		
F 4035 53	25	10	+			+			+		
F 4035 04	32	16		+			+			+	
F 4035 44	32	16		+			+			+	
F 4035 05	40	25		+			+			+	
F 4035 45	40	25		+			+			+	
F 4035 16	50	40		+			+			+	
F 4035 56	50	40		+			+			+	
F 4035 07	65	63		+			+			+	
F 4035 47	65	63			+			+			+
F 4035 08	80	100		+			+			+	
F 4035 48	80	100			+			+			+
F 4035 09	100	160			+			+			+
F 4035 49	100	160			+			+			+
F 4035 10	125	250			+			+			+
F 4035 50	125	250			+			+			+
F 4035 41	150	330			+			+			+
F 4035 52	150	330			+			+			+
3-port valves											
F 4037 01	15	1	+			+			+		
F 4037 11	15	1,6	+			+			+		
F 4037 21	15	2,5	+			+			+		
F 4037 31	15	4	+			+			+		
F 4037 03	25	6,3	+			+			+		
F 4037 13	25	10	+			+			+		
F 4037 04	32	16		+			+			+	
F 4037 05	40	25		+			+			+	
F 4037 16	50	40		+			+			+	
F 4037 07	65	63		+			+			+	
F 4037 08	80	100		+			+			+	
F 4037 09	100	160			+			+			+
F 4037 10	125	250			+			+			+
F 4037 41	150	330			+			+			+

Safety notes

- This device has been designed for use in stationary heating, ventilation and air-conditioning systems and must not be used outside the specified field of application, especially in aircraft or in any other airborne means of transport.
- Outdoor application: only possible in case that no (sea) water, snow, ice, insulation or aggressive gases interfere directly with the device and that it is ensured that the ambient conditions remain within the thresholds according to the data sheet at any time.
- Only authorised specialists may carry out installation. All applicable legal or institutional installation regulations must be complied during installation.
- The switch for changing the direction of motion and so the closing point may be adjusted only by authorised specialists. The direction of motion is critical, particularly in connection with frost protection circuits.
- The device may only be opened at the manufacturer's site. It does not contain any parts that can be replaced or repaired by the user.
- The device contains electrical and electronic components and must not be disposed of as household refuse. All locally valid regulations and requirements must be observed.

Please note: all diagrams are indicative in nature and do not claim to be complete.

All specifications and statements within this brochure are according to information available at the time of printing and meant for informational purpose only. Herz Armaturen reserves the right to modify and change products as well as its technical specifications and/or its functioning according to technological progress and requirements. It is understood that all images of Herz products are symbolic representations and therefore may visually differ from the actual product. Colours may differ due to printing technology used. In case of any further questions don't hesitate to contact your closest HERZ Branch-office.