

HERZ Actuators for HERZ Combi Valves

Data sheet for Actuators 7713, Issue 0523

☑ Dimensions for actuator 24V, control modulating, communicative 0...10 V variable, conversion of sensor signals, communication via MP-Bus, [mm]

F 7713 01, F 7713 02

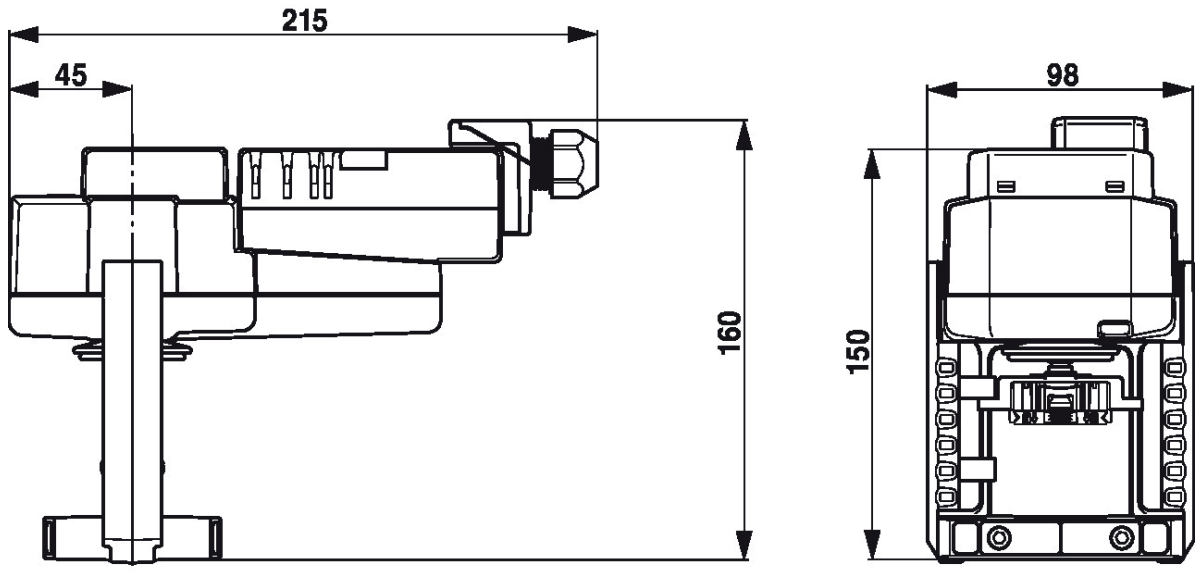

F 7713 03

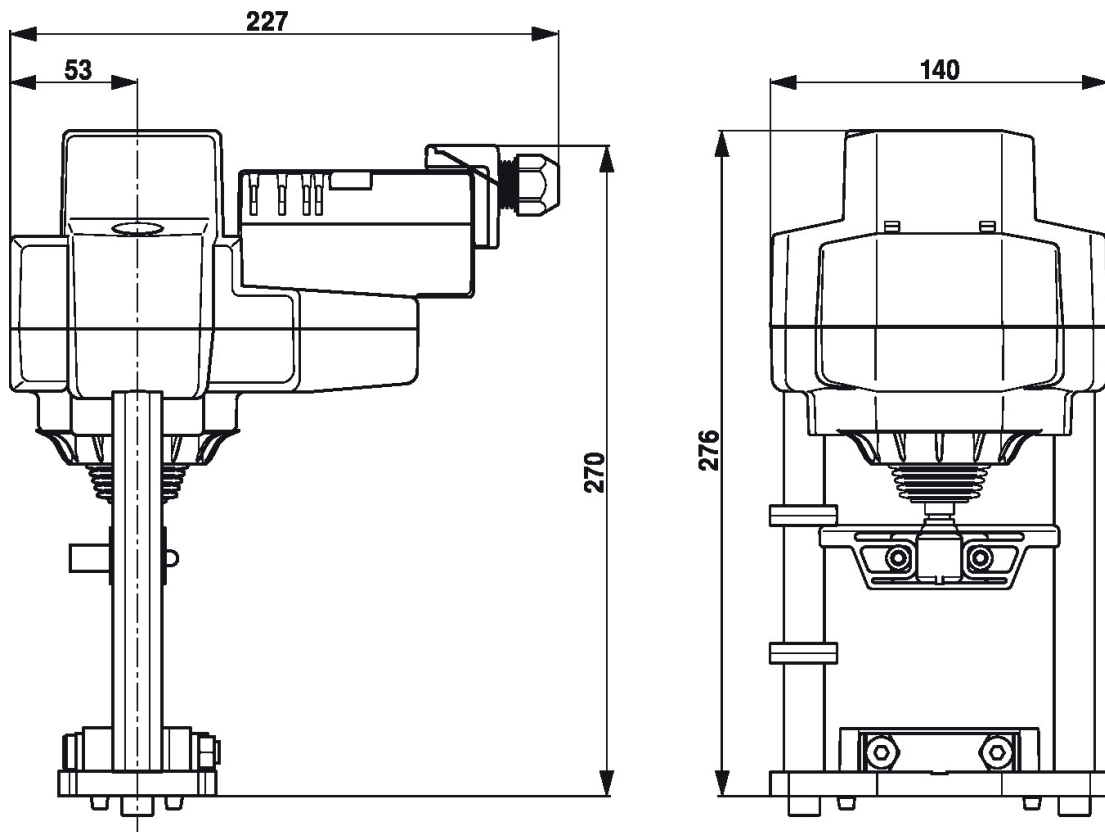

☑ Technical data

Modulating, conversion of sensor signals		F 7713 01	F 7713 02	F 7713 03
Electrical data	Nominal voltage	AC / DC 24 V		
	Nominal voltage frequency	50/60 Hz		
	Nominal voltage range	AC 19.2...28.8 V / DC 21.6...28.8 V		
	Power consumption in operation	2 W	1,5 W	4 W
	Power consumption in rest position	1,5 W	0,5 W	1,5 W
	Power consumption for wire sizing	4 VA	3 VA	6 VA
	Connection supply / control	Terminals with cable 1 m, 4 x 0.75 mm ² (Terminal 4 mm ²)		
	Parallel operation	Yes (note the performance data)		
Data bus communication	Communicative control	MP-Bus		
	Number of nodes	MP-Bus max. 8		
Functional data	Actuating force motor	500 N	1000 N	2500 N
	Operating range Y (default)	2...10 V		
	Input Impedance	100 kΩ		
	<i>Operating range Y variable (programmable)</i>	<i>Start point 0.5...30 V End point 2.5...32 V</i>		
	Operating modes optional	Open/close 3-point (AC only) Modulating (DC 0...32 V)		
	Position feedback U (default)	2...10 V		
	Position feedback U note	Max. 0.5 mA		
	<i>Position feedback U variable (programmable)</i>	<i>Start point 0.5...8 V End point 2...10 V</i>	<i>Start point 0.5...8 V End point 2.5...10 V</i>	
	Position accuracy	±5%		
	Manual override	with push-button, can be locked		
	Stroke	15 mm	20 mm	40 mm
	Running time motor (default)	150 s / 15 mm	150 s / 20 mm	150 s / 40 mm
	<i>Running time motor variable (programmable)</i>	<i>90...150 s</i>		
	Adaptation setting range (default)	manual (automatic on first power-up)		
	<i>Adaptation setting range variable (programmable)</i>	<i>No action Adaptation when switched on Adaptation after pushing the manual override button</i>		
	Override control (default)	MAX (maximum position) = 100% MIN (minimum position) = 0% ZS (intermediate position, AC only) = 50%		
	<i>Override control variable (programmable)</i>	<i>MAX = (MIN + 33%)...100% ZS = MIN...MAX</i>		
	Sound power level, motor	45 dB (A)	45 dB (A)	56 dB (A)
	Position indication	Mechanically, 5...15 mm stroke	Mechanically, 5...20 mm stroke	Mechanically, 5...40 mm stroke
Actuator characteristics (default)	equal percentage			

Safety data	Protection class IEC/EN	III, Safety Extra-Low Voltage (SELV)		
	Power source UL	Class 2 Supply		
	Degree of protection IEC/EN	IP54		
	Degree of protection NEMA/UL	NEMA 2		
	Enclosure	UL Enclosure Type 2		
	EMC	CE according to 2014/30/EG		
	Certification IEC/EN	IEC/EN 60730-1 and IEC/EN 60730-2-14		
	UL Approval	cULus according to UL60730-1A, UL60730-2-14 and CAN/CSA E60730-1 The UL marking on the actuator depends on the production site, the device is UL-compliant in any case		
	Mode of operation	Type 1		
	Rated impulse voltage supply / control	0.8 kV		
	Pollution degree	3		
	Ambient temperature	0 °C ... 50 °C [32...122°F]		
	Storage temperature	-40 °C ... 80 °C [-40...176°F]		
	Ambient humidity	Max. 95% RH, non-condensing		
	Servicing	maintenance-free		
kg	Weight ~	1,2 kg	1,2 kg	3,6 kg

 Safety notes



- This device has been designed for use in stationary heating, ventilation and air-conditioning systems and must not be used outside the specified field of application, especially in aircraft or in any other airborne means of transport.
- Outdoor application: only possible in case that no (sea) water, snow, ice, insolation or aggressive gases interfere directly with the device and that it is ensured that the ambient conditions remain within the thresholds according to the data sheet at any time.
- Only authorised specialists may carry out installation. All applicable legal or institutional installation regulations must be complied during installation.
- The switch for changing the direction of motion and so the closing point may be adjusted only by authorised specialists. The direction of motion is critical, particularly in connection with frost protection circuits.
- The device may only be opened at the manufacturer's site. It does not contain any parts that can be replaced or repaired by the user.
- The device contains electrical and electronic components and must not be disposed of as household refuse. All locally valid regulations and requirements must be observed.

☑ Mode of operation

Conventional operation:

The actuator is connected with a standard control signal of 0...10 V and drives to the position defined by the control signal. The measuring voltage U serves for the electrical display of the actuator position 0.5...100% and as control signal for other actuators.

Operation on Bus:

The actuator receives its digital control signal from the higher level controller via the MP-Bus and drives to the position defined. Connection U serves as communication interface and does not supply an analogue measuring voltage.

☑ Converter for sensors

Connection option for a sensor (passive or active sensor or switching contact). The MP actuator serves as an analogue/digital converter for the transmission of the sensor signal via MP-Bus to the higher level system.

☑ Parametrisable actuators

The factory settings cover the most common applications. Single parameters can be modified with the Service Tools MFT-P or ZTH EU.

☑ Simple direct mounting

Simple direct mounting on the globe valve by means of form-fit hollow clamping jaws. The actuator can be rotated by 360° on the valve neck.

☑ Manual override

Manual override with push-button possible (the gear train is disengaged for as long as the button is pressed or remains locked).

The stroke can be adjusted by using a hexagon socket screw key (4mm/5mm), which is inserted into the top of the actuator. The stroke shaft extends when the key is rotated clockwise.

☑ High functional reliability

The actuator is overload protected, requires no limit switches and automatically stops when the end stop is reached.

☑ Home position

Factory setting: Actuator stem is retracted.

The first time the supply voltage is switched on, i.e. at the time of commissioning, the actuator carries out an adaptation, which is when the operating range and position feedback adjust themselves to the mechanical setting range. The actuator then moves into the position defined by the control signal.

☑ Adaptation and synchronisation

An adaptation can be triggered manually by pressing the "Adaptation" button or with the PCTool. Both mechanical end stops are detected during the adaptation (entire setting range).

Automatic synchronisation after pressing the manual override button is configured. The synchronisation is in the home position (0%).

The actuator then moves into the position defined by the control signal.

A range of settings can be adapted using the PC-Tool.

☑ Setting direction of motion

When actuated, the stroke direction switch changes the running direction in normal operation.

☑ Accessories

	Description	Type
Gateways	Gateway MP zu BACnet MS/TP	UK24BAC
	Gateway MP to Modbus RTU	UK24MOD
Electrical accessories	Auxiliary switch 2 x SPDT add-on	S2A-H
	MP-Bus power supply for MP actuators	ZN230-24MP
Tools	Service Tool, with ZIP-USB function, for parametrisable and communicative actuators, VAV controller and HVAC performance devices	ZTH EU
	PC-Tool, Software for adjustments and diagnostics	MFT-P
	Adapter for Service-Tool ZTH	MFT-C
	Connection cable 5 m, A: RJ11 6/4 ZTH EU, B: 6-pin for connection to service socket	ZK1-GEN
	Connection cable 5 m, A: RJ11 6/4 ZTH EU, B: free wire end for connection to MP/PP terminal	ZK2-GEN

Electrical installation



Supply from isolating transformer.
 Parallel connection of other actuators possible. Observe the performance data.
 Direction of stroke switch factory setting: Actuator stem retracted (▲).

Wiring diagrams

AC/DC 24 V, modulating

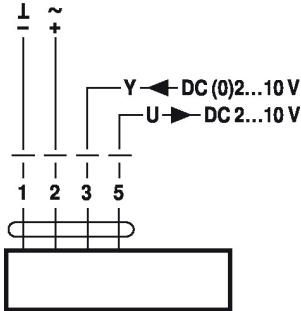

Cable colours:

- 1 = black
- 2 = red
- 3 = white
- 5 = orange

Operation on the MP-Bus

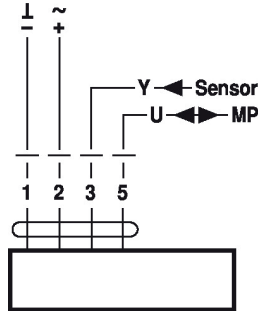

Cable colours:

- 1 = black
- 2 = red
- 3 = white
- 5 = orange

Connection of active sensors

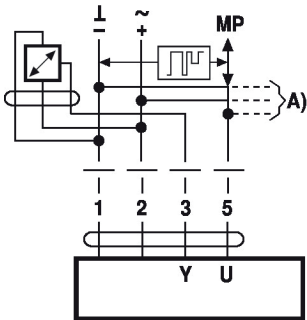

- A) additional MP-Bus nodes (max. 8)
- Supply AC/DC 24 V
 - Output signal DC 0...10 V (max. DC 0...32 V)
 - Resolution 30 mV

Connection of external switching contact

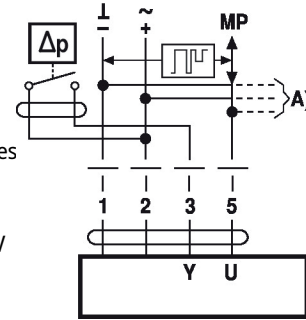

- A) additional MP-Bus nodes (max. 8)
- Switching current 16 mA @ 24 V
 - Start point of the operating range must be parametrised on the MP actuator as ≥ 0.5 V

Connection of passive sensors

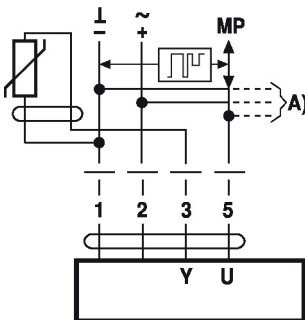

NI1000	-28...+98°C	850...1600 Ω^2
PT1000	-35...+155°C	850...1600 Ω^2
NTC	-10...+160°C ¹⁾	200 Ω ...60 k Ω^2

A) additional MP-Bus nodes (max. 8)

- 1) Depending on the type
 - 2) Resolution 1 Ohm
- Compensation of the measured value is recommended

Functions

Functions when operated on MP-Bus

Connection on the MP-Bus

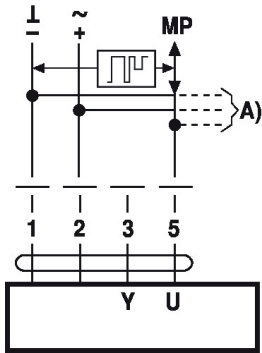

A) additional MP-Bus nodes (max. 8)

MP-Bus Network topology

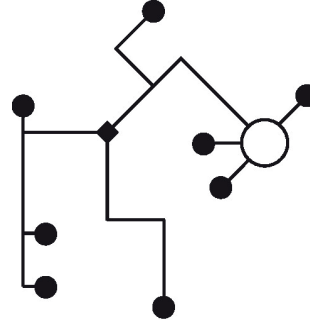

There are no restrictions for the network topology (star, ring, tree or mixed forms are permitted). Supply and communication in one and the same 3-wire cable

- no shielding or twisting necessary
- no terminating resistors required

Functions with basic values (conventional mode)

Override control with AC 24 V with relay contacts

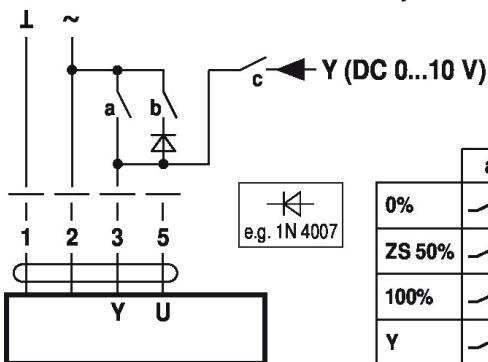

	a	b	c
0%	—	—	—
ZS 50%	—	—	—
100%	—	—	—
Y	—	—	—

Override control with AC 24 V with rotary switch

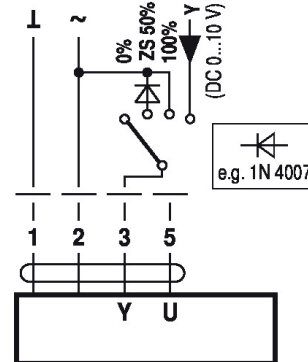

Control remotely 0...100% with positioner SG..

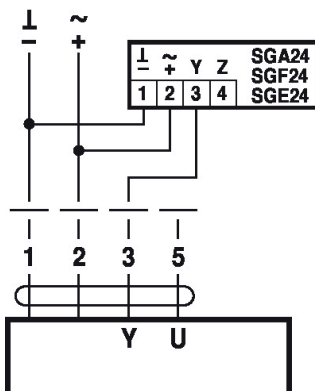

Minimum limit with positioner SG..

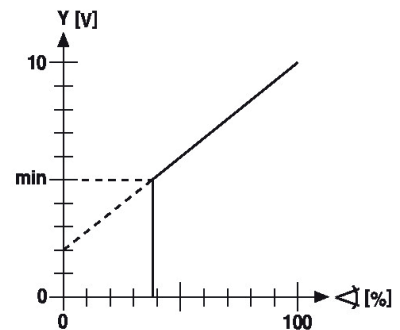
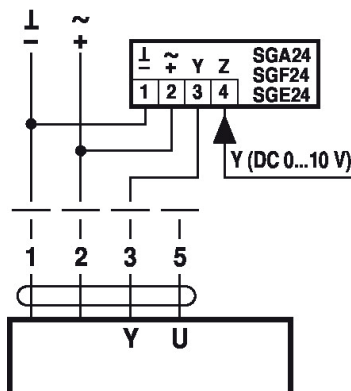

Follow-up control (position-dependent)

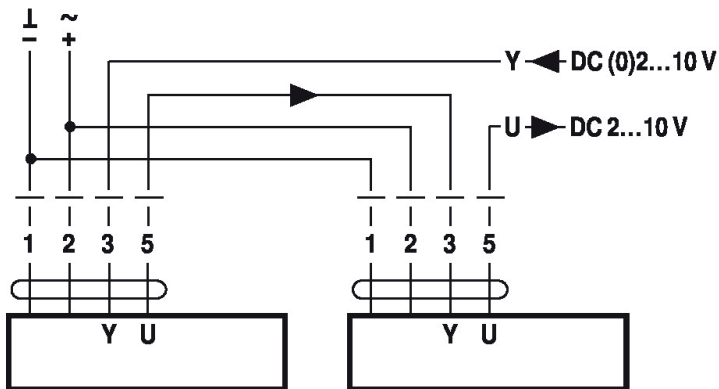

Control with 4...20 mA via external resistor

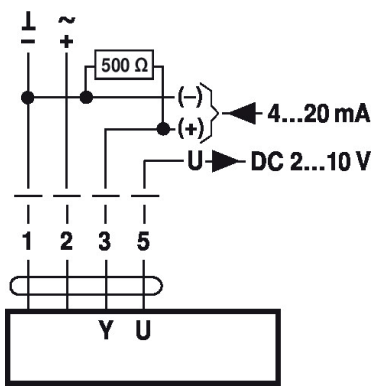

Caution:
 The operating range must be set to DC 2...10 V.
 The 500 Ω resistor converts the 4...20 mA current signal to a voltage signal DC 2...10 V

Functional check

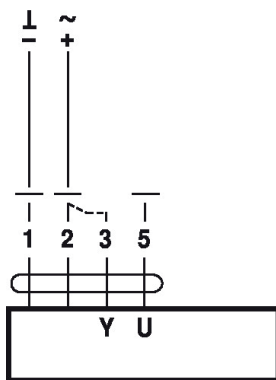

Procedure

1. Apply 24 V to connection 1 and 2
2. Disconnect connection 3:
 - with upwards direction of motion: closing point at top
 - with downwards direction of motion: closing point at bottom
3. Short circuit connections 2 and 3:
 - Actuator runs in the opposite direction

Functions with specific parameters (parametrisation necessary)

Override control and limiting with AC 24 V with relay contacts

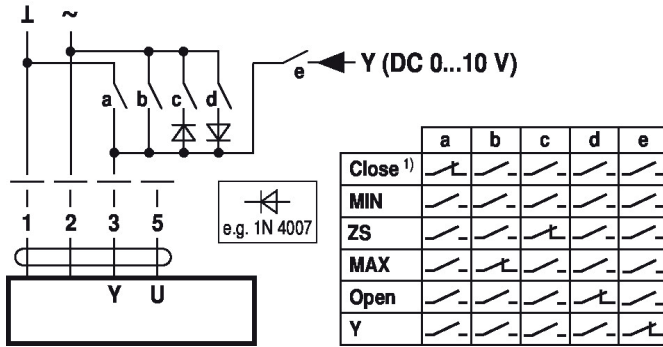

Override control and limiting with AC 24 V with rotary switch

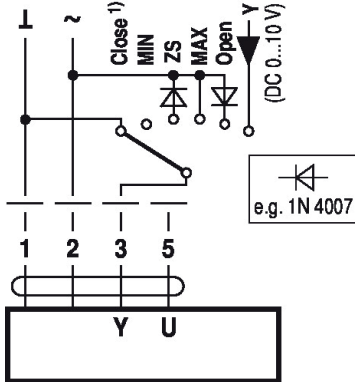

1) **Caution:** This function is only guaranteed if the start point of the operating range is defined as min. 0.5 V.

Control open/close

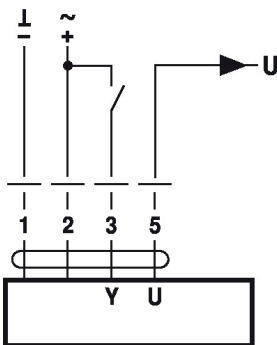

Control 3-point

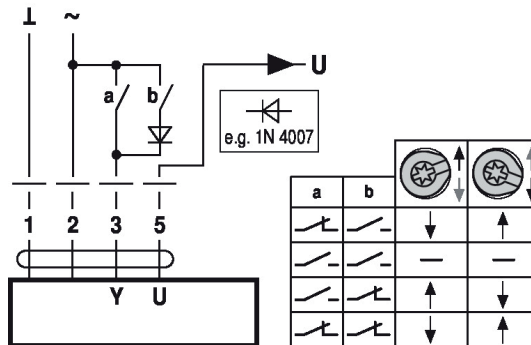

☑ **Operating controls and indicators**

F 7713 01, 02, 03

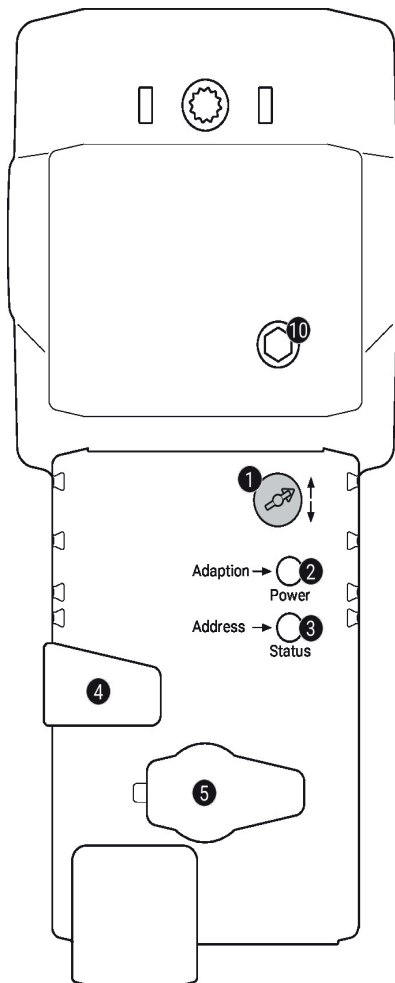

1 Direction of stroke switch

Switch over: Direction of stroke changes

2 Push-button and LED display green

Off: No power supply or malfunction

On: In operation

Press button: Triggers stroke adaptation, followed by standard mode

3 Push-button and LED display yellow

Off: Standard mode

On: Adaptation or synchronisation process active

Flickering: MP-Bus communication active

Flashing: Request for addressing from MP client

Press button: Confirmation of the addressing

4 Manual override button

Press button: Gear train disengages, motor stops, manual override possible

Release button: Gear train engages, standard mode

5 Service plug

For connecting parametrisation and service tools

10 Manual override

Clockwise: Actuator stem extends

Counterclockwise: Actuator stem retracts

☑ **Disposal notice**

The disposal of HERZ actuators must not endanger the health or the environment. National legal regulations for proper disposal of the HERZ actuators have to be followed.

Service**Tools connection**

The actuator can be parametrised by ZTH EU via the service socket.

For an extended parametrisation the PC tool can be connected.

Connection ZTH EU / PC-Tool

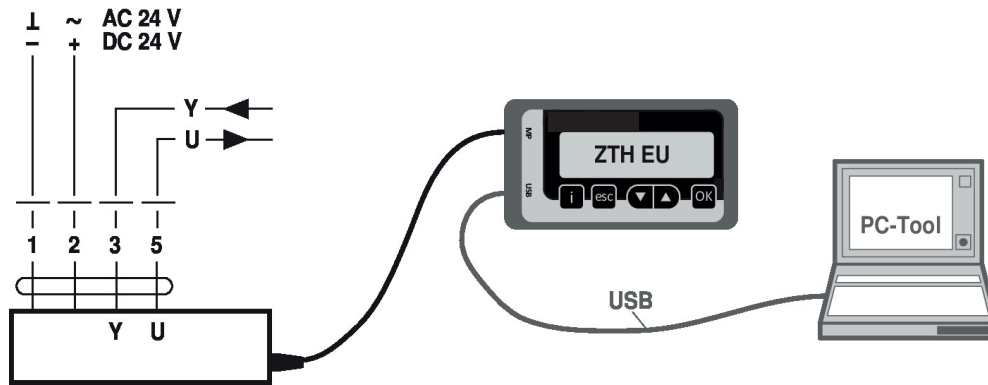

Actuator selection for HERZ valves

Order number voltage / control / force / stroke			F 7713 01 24V, 2-10V 500N, 15mm	F 7713 02 24V, 2-10V 1000N, 20mm	F 7713 03 24V, 2-10V 2500N, 40mm
Combi valve	DN	kvs			
F 4006 71	15	2,5	+		
F 4006 90	15	2,5	+		
F 4006 72	15	4	+		
F 4006 91	15	4	+		
F 4006 73	25	6,3	+		
F 4006 92	25	6,3	+		
F 4006 93	25	8	+		
F 4006 53	25	8	+		
F 4006 74	32	12	+		
F 4006 94	32	12	+		
F 4006 75	40	20	+		
F 4006 95	40	20	+		
F 4006 80	50	32	+		
F 4006 96	50	32	+		
F 4006 81	65	50			+
F 4006 97	65	50			+
F 4006 82	80	80			+
F 4006 98	80	80			+
F 4006 83	100	125			+
F 4006 99	100	125			+
F 4006 84	125	180			+
F 4006 10	125	180			+
Combi valve	DN	kvs			
F 4006 62	50		+		
F 4006 63	65		+		
F 4006 64	80			+	
F 4006 65	100			+	
F 4006 66	125				+
F 4006 56	125 HF				+
F 4006 67	150				+
F 4006 57	150 HF				+
F 4006 68	200 SF				+
F 4006 58	200 HF				+
F 4006 48	200UHF				+
F 4006 69	250 SF				+
F 4006 59	250 HF				+

Please note: all diagrams are indicative in nature and do not claim to be complete.

All specifications and statements within this brochure are according to information available at the time of printing and meant for informational purpose only. Herz Armaturen reserves the right to modify and change products as well as its technical specifications and/or its functioning according to technological progress and requirements. It is understood that all images of Herz products are symbolic representations and therefore may visually differ from the actual product. Colours may differ due to printing technology used. In case of any further questions don't hesitate to contact your closest HERZ Branch-office.