

- D H409 06 DHS 93 kW at primary 85/52 °C and secondary 70/50 °C
- D H409 07 DHS 108 kW at primary 85/52 °C and secondary 70/50 °C
- D H409 08 DHS 122 kW at primary 85/52 °C and secondary 70/50 °C
- D H409 09 DHS 135 kW at primary 85/52 °C and secondary 70/50 °C
- D H409 10 DHS 148 kW at primary 85/52 °C and secondary 70/50 °C
- D H409 11 DHS 172 kW at primary 85/52 °C and secondary 70/50 °C
- D H409 12 DHS 194 kW at primary 85/52 °C and secondary 70/50 °C
- D H409 13 DHS 213 kW at primary 85/52 °C and secondary 70/50 °C
  
- D H410 06 DHS incl. insulation
- D H410 07 DHS incl. insulation
- D H410 08 DHS incl. insulation
- D H410 09 DHS incl. insulation
- D H410 10 DHS incl. insulation
- D H410 11 DHS incl. insulation
- D H410 12 DHS incl. insulation
- D H410 13 DHS incl. insulation

## 1. Description

The compact district heating substation is the link between the district heating system (primary system) and the building's heating system (secondary system). The medium flows through the primary flow line, over the strainer, into the heat exchanger, where heat is exchanged with the secondary side (building system). The medium then flows through the primary return line via a combi-valve - pressure-independent control valve back into the district heating network. The adapter for the heat meter is installed in the return line. A safety valve is located on the secondary side (building system). The safety valve serves exclusively to protect the district substation and is not designed to protect the building's heating system.

### District heating (primary side):

- Max. operating pressure: 16 bar
- Max. operating temperature: 100 °C
- Connection on the left

### Heating (secondary side):

- Max. operating pressure: 16 bar, protected with 3 bar
- Max. operating temperature: 90 °C
- Connection from above.

## 2. Components

### ***District heating primary:***

- 1 thermometer in supply and return
  - 1 combi-valve - pressure-independent control valve for dynamic constant maintenance of the preset flow rate and with mounting for gear motor.
- The 230 V/3-point, 24 V/3-point, 24 V/0-10 V or 24 V/0-10 V failsafe geared motor must be ordered as an accessory.
- Spacer 260 - 300 mm (depending on size) with union nuts for heat meters. Operation with spacer without heat meter is possible.
  - 2 pcs. immersion pockets to accommodate the sensors for heat meters.
  - Insertion pocket for control sensor return district heating
  - 1 strainer with drain ball valve
  - Emptying with drain valve with protective cap
  - Primary side connections: freely rotating union nut.

### ***Heat exchanger:***

- Stainless steel heat exchanger made of AISI 316/1.4401, soldered. Insulation made of PU rigid foam with wipe-clean plastic skin. Maximum primary pressure loss at the heat exchanger: 15 kPa. Maximum pressure loss at the secondary heat exchanger: 15 kPa. Return flow coefficient: maximum 2 K at design conditions or depending on project specifications.

### ***Secondary heating:***

- Safety valve 3 bar;
- Immersion pocket for flow heating control sensor;
- Secondary side connections: freely rotating union nut.

### ***General:***

Pipework made of seamless drawn boiler pipe P235GH, generously dimensioned and low flow velocities for low pressure losses. Pipe insulation made of elastomeric foam based on synthetic rubber, with a thickness of 19 mm, thermal conductivity of 0.040 W/m·K at 0 °C, and fire behavior classification BLs1d0 according to EN 13501-1.

The district heating substation is on a steel frame construction.

## 3. Principle schemes

The compact district heating transfer station is specially designed to ensure maximum comfort for our customers while enabling efficient energy use. It is manufactured according to the strict technical requirements of heat energy distributors and can be seamlessly integrated into central control and monitoring systems.

The application example shows basic diagrams and does not include all the details for installation. Installation is carried out according to local conditions, specific dimensions, and applicable regulations.

## 4. Materials note

Pursuant to Article 33 of the REACH Regulation (EC No. 1907/2006), we are obliged to point out that the material lead is listed on the SVHC list and that all brass components manufactured in our products exceed 0.1% (w / w) lead (CAS: 7439-92-1 / EINECS: 231-100-4). Since lead is a component part of an alloy, actual exposure is not possible and therefore no additional information on safe use is necessary.

## 5. Water quality

Water purity in accordance with the ÖNORM H 5195 and VDI 2035 standards.

## 6. Disposal

Local and currently applicable legislation must be observed for disposal. The disposal of HERZ District heating substation must not endanger the health or the environment.

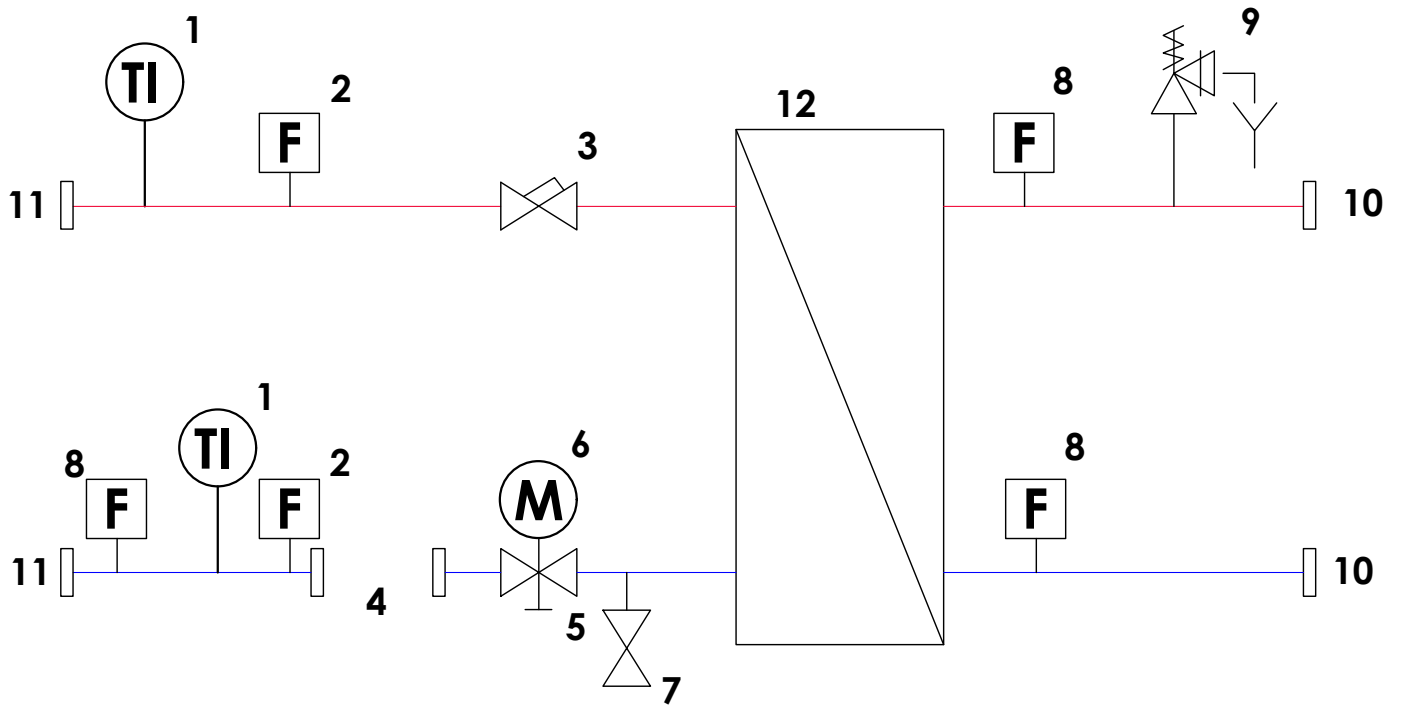

- 1 Thermometer
- 2 Immersion pocket for heat meter
- 3 Strainer
- 4 Spacer for heat meters, pressure and temperature resistant
- 5 Combi-valve - pressure-independent control valve
- 6 Geared motor
- 7 Drain valve
- 8 Insertion pocket for control
- 9 Safety valve
- 10 Secondary connection
- 11 Primary connection
- 12 Heat exchanger

**Power data for D H409 06 and D H410 06**

- Pressure-independent control valve DN32 1 **4406** 34 and strainer DN40 1 **2662** 05 integrated in the primary side
- Max. return temperature efficiency: 2 K
- Max.  $\Delta p$  primary side / secondary side of the heat exchanger: 15 kPa
- Heat exchanger: 60 plates

T °C SUP/RET, Heating secondary	V - Flow rate, Q - Power		Units	District heating, primary								
				60 °C	65 °C	70 °C	75 °C	80 °C	85 °C	90 °C	95 °C	100 °C
95/70	V	primary	l/h	-	-	-	-	-	-	-	-	1245
	Q		kW	-	-	-	-	-	-	-	-	39
	V	secondary	l/h	-	-	-	-	-	-	-	-	1378
90/60	V	primary	l/h	-	-	-	-	-	-	-	731	1765
	Q		kW	-	-	-	-	-	-	-	27	75
	V	secondary	l/h	-	-	-	-	-	-	-	792	2201
85/60	V	primary	l/h	-	-	-	-	-	-	1111	2593	2730
	Q		kW	-	-	-	-	-	-	35	96	118
	V	secondary	l/h	-	-	-	-	-	-	1231	3377	4151
80/65	V	primary	l/h	-	-	-	-	-	3462	2481	2130	1821
	Q		kW	-	-	-	-	-	71	68	71	71
	V	secondary	l/h	-	-	-	-	-	4162	3986	4162	4162
80/60	V	primary	l/h	-	-	-	-	-	1928	2831	2446	2123
	Q		kW	-	-	-	-	-	50	91	94	94
	V	secondary	l/h	-	-	-	-	-	2196	3997	4129	4129
75/50	V	primary	l/h	-	-	-	-	1012	2311	2607	2366	2118
	Q		kW	-	-	-	-	32	86	113	117	117
	V	secondary	l/h	-	-	-	-	1121	3012	3958	4098	4098
70/55	V	primary	l/h	-	-	-	3425	2553	2092	1735	1564	1393
	Q		kW	-	-	-	70	70	70	68	70	70
	V	secondary	l/h	-	-	-	4087	4087	4087	3970	4087	4087
70/50	V	primary	l/h	-	-	-	1728	2899	2414	2024	1855	1670
	Q		kW	-	-	-	45	93	93	90	93	93
	V	secondary	l/h	-	-	-	1968	4068	4068	3937	4068	4068
65/40	V	primary	l/h	-	-	882	2061	2680	2341	2019	1897	1740
	Q		kW	-	-	28	77	116	116	112	116	116
	V	secondary	l/h	-	-	977	2687	4047	4047	3908	4047	4047
60/45	V	primary	l/h	-	3074	2516	2056	1754	1534	1327	1233	1124
	Q		kW	-	63	69	69	69	69	67	69	69
	V	secondary	l/h	-	3663	4012	4012	4012	4012	3896	4012	4012
60/40	V	primary	l/h	-	1491	2874	2386	2063	1827	1590	1497	1376
	Q		kW	-	39	92	92	92	92	89	92	92
	V	secondary	l/h	-	1699	4009	4009	4009	4009	3878	4009	4009
60/30	V	primary	l/h	-	480	1206	1972	2519	2280	2002	1915	1778
	Q		kW	-	18	52	96	137	138	133	138	138
	V	secondary	l/h	-	522	1508	2783	3972	4001	3856	4001	4001

T °C SUP/RET, Heating secondary	V - Flow rate, Q - Power		Units	District heating, primary								
				60 °C	65 °C	70 °C	75 °C	80 °C	85 °C	90 °C	95 °C	100 °C
55/30	V	primary	l/h	753	1757	2636	2297	2050	1857	1657	1573	1463
	Q		kW	24	66	114	114	114	114	111	114	114
	V	secondary	l/h	834	2294	3963	3963	3963	3963	3858	3963	3963
50/35	V	primary	l/h	2482	2022	1722	1506	1340	1208	1069	1013	938
	Q		kW	68	68	68	68	68	68	66	68	68
	V	secondary	l/h	3940	3940	3940	3940	3940	3940	3824	3940	3940
50/30	V	primary	l/h	2755	2360	2036	1801	1619	1473	1309	1252	1167
	Q		kW	88	91	91	91	91	91	88	91	91
	V	secondary	l/h	3820	3951	3951	3951	3951	3951	3820	3951	3951
45/35	V	primary	l/h	1585	1319	1133	994	886	799	713	670	621
	Q		kW	45	45	45	45	45	45	44	45	45
	V	secondary	l/h	3907	3907	3907	3901	3907	3907	3820	3907	3907
45/30	V	primary	l/h	2021	1720	1503	1337	1205	1099	980	935	871
	Q		kW	68	68	68	68	68	68	66	68	68
	V	secondary	l/h	3933	3933	3933	3933	3933	3933	3817	3933	3933
40/30	V	primary	l/h	1317	1130	991	883	797	727	639	619	577
	Q		kW	45	45	45	45	45	45	43	45	45
	V	secondary	l/h	3900	3900	3900	3900	3900	3900	3727	3900	3900

**Power data for D H409 07 and D H410 07**

- Pressure-independent control valve DN32 1 **4406** 34 and strainer DN40 1 **2662** 05 integrated in the primary side
- Max. return temperature efficiency: 2 K
- Max.  $\Delta p$  primary side / secondary side of the heat exchanger: 15 kPa
- Heat exchanger: 70 plates

T °C SUP/RET, Heating secondary	V - Flow rate, Q - Power		Units	District heating, primary								
				60 °C	65 °C	70 °C	75 °C	80 °C	85 °C	90 °C	95 °C	100 °C
95/70	V	primary	l/h	-	-	-	-	-	-	-	-	1501
	Q		kW	-	-	-	-	-	-	-	-	47
	V	secondary	l/h	-	-	-	-	-	-	-	-	1660
90/60	V	primary	l/h	-	-	-	-	-	-	-	838	2095
	Q		kW	-	-	-	-	-	-	-	31	89
	V	secondary	l/h	-	-	-	-	-	-	-	910	2612
85/60	V	primary	l/h	-	-	-	-	-	-	1334	3080	3143
	Q		kW	-	-	-	-	-	-	42	114	136
	V	secondary	l/h	-	-	-	-	-	-	1477	4010	4784
80/65	V	primary	l/h	-	-	-	-	-	3990	2881	2459	2103
	Q		kW	-	-	-	-	-	82	79	82	82
	V	secondary	l/h	-	-	-	-	-	4807	4631	4807	4807
80/60	V	primary	l/h	-	-	-	-	-	2315	3296	2835	2461
	Q		kW	-	-	-	-	-	60	106	109	109
	V	secondary	l/h	-	-	-	-	-	2635	4656	4787	4787
75/50	V	primary	l/h	-	-	-	-	1169	2741	3020	2729	2443
	Q		kW	-	-	-	-	37	102	131	135	135
	V	secondary	l/h	-	-	-	-	1296	3573	4589	4729	4729
70/55	V	primary	l/h	-	-	-	3955	2952	2420	2016	1810	1612
	Q		kW	-	-	-	81	81	81	79	81	81
	V	secondary	l/h	-	-	-	4729	4729	4729	4612	4729	4729
70/50	V	primary	l/h	-	-	-	2035	3363	2803	2361	2153	1940
	Q		kW	-	-	-	53	108	108	105	108	108
	V	secondary	l/h	-	-	-	2318	4724	4724	4593	4724	4724
65/40	V	primary	l/h	-	-	1039	2463	3068	2682	2342	2191	2010
	Q		kW	-	-	33	92	133	133	130	134	134
	V	secondary	l/h	-	-	1151	3210	4640	4640	4536	4675	4675
60/45	V	primary	l/h	-	3661	2915	2383	2033	1779	1544	1429	1303
	Q		kW	-	75	80	80	80	80	78	80	80
	V	secondary	l/h	-	4361	4652	4652	4652	4652	4536	4652	4652
60/40	V	primary	l/h	-	1758	3306	2746	2376	2104	1858	1725	1585
	Q		kW	-	46	106	106	106	106	104	106	106
	V	secondary	l/h	-	2004	4619	4619	4619	4619	4531	4619	4619
60/30	V	primary	l/h	-	560	1439	2320	2922	2625	2332	2205	2048
	Q		kW	-	21	62	113	159	159	155	159	159
	V	secondary	l/h	-	609	1798	3276	4610	4610	4494	4610	4610

T °C SUP/RET, Heating secondary	V - Flow rate, Q - Power		Units	District heating, primary								
				60 °C	65 °C	70 °C	75 °C	80 °C	85 °C	90 °C	95 °C	100 °C
55/30	V	primary	l/h	877	2077	3049	2658	2372	2150	1910	1821	1695
	Q		kW	28	78	132	132	132	132	128	132	132
	V	secondary	l/h	973	2711	4588	4588	4588	4588	4449	4588	4588
50/35	V	primary	l/h	2881	2348	2000	1749	1557	1404	1247	1177	1090
	Q		kW	79	79	79	79	79	79	77	79	79
	V	secondary	l/h	4577	4577	4577	4577	4577	4577	4461	4577	4577
50/30	V	primary	l/h	3255	2720	2348	2077	1868	1700	1517	1445	1346
	Q		kW	104	105	105	105	105	105	102	105	105
	V	secondary	l/h	4515	4558	4558	4558	4558	4558	4428	4558	4558
45/35	V	primary	l/h	1831	1525	1309	1148	1023	924	826	775	717
	Q		kW	52	52	52	52	52	52	51	52	52
	V	secondary	l/h	4515	4515	4515	4515	4515	4515	4428	4515	4515
45/30	V	primary	l/h	2317	1972	1723	1533	1383	1260	1129	1073	1000
	Q		kW	78	78	78	78	78	78	76	78	78
	V	secondary	l/h	4511	4511	4511	4511	4511	4511	4395	4511	4511
40/30	V	primary	l/h	1521	1306	1145	1021	921	840	757	715	666
	Q		kW	52	52	52	52	52	52	51	52	52
	V	secondary	l/h	4507	4507	4507	4507	4507	4507	4420	4507	4507

**Power data for D H409 08 and D H410 08**

- Pressure-independent control valve DN32 1 **4406** 34 and strainer DN40 1 **2662** 05 integrated in the primary side
- Max. return temperature efficiency: 2 K
- Max.  $\Delta p$  primary side / secondary side of the heat exchanger: 15 kPa
- Heat exchanger: 80 plates

T °C SUP/RET, Heating secondary	V - Flow rate, Q - Power		Units	District heating, primary									
				60 °C	65 °C	70 °C	75 °C	80 °C	85 °C	90 °C	95 °C	100 °C	
95/70	V	primary	l/h	-	-	-	-	-	-	-	-	-	1725
	Q		kW	-	-	-	-	-	-	-	-	-	54
	V	secondary	l/h	-	-	-	-	-	-	-	-	-	1908
90/60	V	primary	l/h	-	-	-	-	-	-	-	-	1001	2425
	Q		kW	-	-	-	-	-	-	-	-	37	103
	V	secondary	l/h	-	-	-	-	-	-	-	-	1086	3022
85/60	V	primary	l/h	-	-	-	-	-	-	-	1524	3567	3557
	Q		kW	-	-	-	-	-	-	-	48	132	154
	V	secondary	l/h	-	-	-	-	-	-	-	1688	4643	5417
80/65	V	primary	l/h	-	-	-	-	-	-	4465	3281	2757	2359
	Q		kW	-	-	-	-	-	-	92	90	92	92
	V	secondary	l/h	-	-	-	-	-	-	5393	5276	5393	5393
80/60	V	primary	l/h	-	-	-	-	-	-	2704	3726	3197	2776
	Q		kW	-	-	-	-	-	-	70	120	123	123
	V	secondary	l/h	-	-	-	-	-	-	3074	5270	5402	5402
75/50	V	primary	l/h	-	-	-	-	1359	3171	3433	3070	2749	
	Q		kW	-	-	-	-	43	118	149	152	152	
	V	secondary	l/h	-	-	-	-	1506	4133	5219	5324	5324	
70/55	V	primary	l/h	-	-	-	4431	3314	2717	2270	2033	1811	
	Q		kW	-	-	-	91	91	91	89	91	91	
	V	secondary	l/h	-	-	-	5313	5313	5313	5196	5313	5313	
70/50	V	primary	l/h	-	-	-	2342	3794	3163	2675	2432	2191	
	Q		kW	-	-	-	61	122	122	119	122	122	
	V	secondary	l/h	-	-	-	2668	5336	5336	5205	5336	5336	
65/40	V	primary	l/h	-	-	1196	2810	3480	3043	2648	2468	2264	
	Q		kW	-	-	38	105	151	151	147	151	151	
	V	secondary	l/h	-	-	1326	3663	5268	5268	5129	5268	5268	
60/45	V	primary	l/h	-	4194	3276	2680	2287	2001	1742	1608	1466	
	Q		kW	-	86	90	90	90	90	88	90	90	
	V	secondary	l/h	-	5001	5234	5234	5234	5234	5117	5234	5234	
60/40	V	primary	l/h	-	2025	3738	3107	2689	2382	2108	1952	1794	
	Q		kW	-	53	120	120	120	120	118	120	120	
	V	secondary	l/h	-	2309	5229	5229	5229	5229	5141	5229	5229	
60/30	V	primary	l/h	-	639	1671	2690	3286	2970	2632	2496	2318	
	Q		kW	-	24	72	131	179	180	175	180	180	
	V	secondary	l/h	-	696	2088	3798	5190	5219	5074	5219	5219	

T °C SUP/RET, Heating secondary	V - Flow rate, Q - Power		Units	District heating, primary								
				60 °C	65 °C	70 °C	75 °C	80 °C	85 °C	90 °C	95 °C	100 °C
55/30	V	primary	l/h	1002	2396	3438	2998	2677	2426	2178	2055	1913
	Q		kW	32	90	149	149	149	149	146	149	149
	V	secondary	l/h	1112	3128	5179	5179	5179	5179	5075	5179	5179
50/35	V	primary	l/h	3242	2644	2253	1970	1753	1582	1409	1326	1228
	Q		kW	89	89	89	89	89	89	87	89	89
	V	secondary	l/h	5156	5156	5156	5156	5156	5156	5040	5156	5156
50/30	V	primary	l/h	3722	3081	2661	2354	2117	1926	1725	1638	1525
	Q		kW	119	119	119	119	119	119	116	119	119
	V	secondary	l/h	5166	5166	5166	5166	5166	5166	5036	5166	5166
45/35	V	primary	l/h	2077	1730	1485	1303	1161	1048	939	879	814
	Q		kW	59	59	15	59	59	59	58	59	59
	V	secondary	l/h	5123	5123	5123	5123	5123	5123	5036	5123	5123
45/30	V	primary	l/h	2643	2249	1966	1749	1578	1438	1292	1224	1140
	Q		kW	89	89	89	89	89	89	87	89	89
	V	secondary	l/h	5147	5147	5147	5147	5147	5147	5031	5147	5147
40/30	V	primary	l/h	1726	1482	1300	1158	1045	953	847	811	756
	Q		kW	59	59	59	59	59	59	57	59	59
	V	secondary	l/h	5114	5114	5114	5114	5114	5114	4940	5114	5114

**Power data for D H409 09 and D H410 09**

- Pressure-independent control valve DN 32 1 **4406 34** and strainer DN 50 1 **2662 06** integrated in the primary side
- Max. return temperature efficiency: 2 K
- Max.  $\Delta p$  primary side / secondary side of the heat exchanger: 15 kPa
- Heat exchanger: 90 plates

T °C SUP/RET, Heating secondary	V - Flow rate, Q - Power		Units	District heating, primary								
				60 °C	65 °C	70 °C	75 °C	80 °C	85 °C	90 °C	95 °C	100 °C
95/70	V	primary	l/h	-	-	-	-	-	-	-	-	1948
	Q		kW	-	-	-	-	-	-	-	-	61
	V	secondary	l/h	-	-	-	-	-	-	-	-	2155
90/60	V	primary	l/h	-	-	-	-	-	-	-	1136	2755
	Q		kW	-	-	-	-	-	-	-	42	117
	V	secondary	l/h	-	-	-	-	-	-	-	1232	3433
85/60	V	primary	l/h	-	-	-	-	-	-	1747	4025	3946
	Q		kW	-	-	-	-	-	-	55	149	171
	V	secondary	l/h	-	-	-	-	-	-	1935	5241	6015
80/65	V	primary	l/h	-	-	-	-	-	4942	3643	3056	2614
	Q		kW	-	-	-	-	-	102	100	102	102
	V	secondary	l/h	-	-	-	-	-	5980	5862	5980	5980
80/60	V	primary	l/h	-	-	-	-	-	3091	4158	3533	3069
	Q		kW	-	-	-	-	-	80	134	136	136
	V	secondary	l/h	-	-	-	-	-	3514	5885	5973	5973
75/50	V	primary	l/h	-	-	-	-	1549	3602	3821	3412	3056
	Q		kW	-	-	-	-	49	134	166	169	169
	V	secondary	l/h	-	-	-	-	1716	4694	5815	5920	5920
70/55	V	primary	l/h	-	-	-	4910	3675	3015	2525	2256	2010
	Q		kW	-	-	-	101	101	101	99	101	101
	V	secondary	l/h	-	-	-	5896	5896	5896	5780	5896	5896
70/50	V	primary	l/h	-	-	-	2648	4193	3498	2965	2691	2424
	Q		kW	-	-	-	69	135	135	132	135	135
	V	secondary	l/h	-	-	-	3018	5905	5905	5774	5905	5905
65/40	V	primary	l/h	-	-	1353	3156	3844	3383	2953	2746	2519
	Q		kW	-	-	43	118	167	168	164	168	168
	V	secondary	l/h	-	-	1500	4117	5827	5862	5722	5262	5862
60/45	V	primary	l/h	-	4781	3636	2977	2540	2223	1940	1786	1629
	Q		kW	-	98	100	100	100	100	98	100	100
	V	secondary	l/h	-	5699	5815	5815	5815	5815	5699	5815	5815
60/40	V	primary	l/h	-	2291	4137	3468	3002	2659	2340	2180	2003
	Q		kW	-	60	133	134	134	134	131	134	134
	V	secondary	l/h	-	2614	5795	5839	5839	5839	5708	5839	5839
60/30	V	primary	l/h	-	747	1903	3060	3650	3281	2947	2772	2576
	Q		kW	-	28	82	149	199	199	196	200	200
	V	secondary	l/h	-	812	2377	4320	5770	5770	5683	5799	5799

T °C SUP/RET, Heating secondary	V - Flow rate, Q - Power		Units	District heating, primary								
				60 °C	65 °C	70 °C	75 °C	80 °C	85 °C	90 °C	95 °C	100 °C
55/30	V	primary	l/h	1127	2715	3826	3339	2981	2702	2417	2289	2131
	Q		kW	36	102	166	166	166	166	162	166	166
	V	secondary	l/h	1251	3546	5770	5770	5770	5770	5631	5770	5770
50/35	V	primary	l/h	3603	2940	2506	2191	1950	1759	1571	1475	1366
	Q		kW	99	99	99	99	99	99	97	99	99
	V	secondary	l/h	5736	5736	5736	5736	5736	5736	5620	5736	5736
50/30	V	primary	l/h	4123	3415	2950	2610	2347	2136	1918	1816	1692
	Q		kW	132	132	132	132	132	132	129	132	132
	V	secondary	l/h	5730	5730	5730	5730	5730	5730	5600	5730	5730
45/35	V	primary	l/h	2323	1935	1661	1457	1299	1172	1037	983	910
	Q		kW	66	66	66	66	66	66	64	66	66
	V	secondary	l/h	5730	5730	5730	5730	5730	5730	5557	5730	5730
45/30	V	primary	l/h	2908	2476	2187	1946	1755	1600	1441	1362	1269
	Q		kW	98	98	99	99	99	99	97	99	99
	V	secondary	l/h	5668	5668	5725	5725	5725	5725	5610	5725	5725
40/30	V	primary	l/h	1902	1632	1431	1276	1151	1050	951	894	833
	Q		kW	65	65	65	65	65	65	64	65	65
	V	secondary	l/h	5634	5634	5634	5634	5634	5634	5547	5634	5634

**Power data for D H409 10 and D H410 10**

- Pressure-independent control valve DN 40 1 **4406** 35 and strainer DN 50 1 **2662** 06 integrated in the primary side
- Max. return temperature efficiency: 2 K
- Max.  $\Delta p$  primary side / secondary side of the heat exchanger: 15 kPa
- Heat exchanger: 100 plates

T °C SUP/RET, Heating secondary	V - Flow rate, Q - Power		Units	District heating, primary								
				60 °C	65 °C	70 °C	75 °C	80 °C	85 °C	90 °C	95 °C	100 °C
95/70	V	primary	l/h	-	-	-	-	-	-	-	-	2171
	Q		kW	-	-	-	-	-	-	-	-	68
	V	secondary	l/h	-	-	-	-	-	-	-	-	2402
90/60	V	primary	l/h	-	-	-	-	-	-	-	1271	3084
	Q		kW	-	-	-	-	-	-	-	47	131
	V	secondary	l/h	-	-	-	-	-	-	-	1379	3844
85/60	V	primary	l/h	-	-	-	-	-	-	1936	4513	4312
	Q		kW	-	-	-	-	-	-	61	167	187
	V	secondary	l/h	-	-	-	-	-	-	2146	5874	6577
80/65	V	primary	l/h	-	-	-	-	-	5418	4005	3355	2871
	Q		kW	-	-	-	-	-	112	110	112	112
	V	secondary	l/h	-	-	-	-	-	6566	6449	6566	6566
80/60	V	primary	l/h	-	-	-	-	-	3396	4556	3868	3361
	Q		kW	-	-	-	-	-	88	147	149	149
	V	secondary	l/h	-	-	-	-	-	3865	6456	6544	6544
75/50	V	primary	l/h	-	-	-	-	1739	4032	4186	3733	3344
	Q		kW	-	-	-	-	55	150	182	185	185
	V	secondary	l/h	-	-	-	-	1927	5254	6375	6480	6480
70/55	V	primary	l/h	-	-	-	5387	4036	3313	2780	2480	2209
	Q		kW	-	-	-	111	111	111	109	111	111
	V	secondary	l/h	-	-	-	6480	6480	6480	6363	6480	6480
70/50	V	primary	l/h	-	-	-	2995	4592	3833	3257	2949	2657
	Q		kW	-	-	-	78	148	148	145	148	148
	V	secondary	l/h	-	-	-	3412	6474	6474	6342	6474	6474
65/40	V	primary	l/h	-	-	1543	3530	4233	3704	3240	3007	2758
	Q		kW	-	-	49	132	184	184	180	184	184
	V	secondary	l/h	-	-	1710	4606	6420	6420	6280	6420	6420
60/45	V	primary	l/h	-	5370	3998	3273	2794	2445	2138	1965	1792
	Q		kW	-	110	110	110	110	110	108	110	110
	V	secondary	l/h	-	6397	6397	6397	6397	6397	6280	6397	6397
60/40	V	primary	l/h	-	2559	4537	3775	3269	2897	2572	2375	2183
	Q		kW	-	67	146	146	146	146	144	146	146
	V	secondary	l/h	-	2919	6361	6361	6361	6361	6274	6361	6361
60/30	V	primary	l/h	-	826	2111	3409	4014	3609	3231	3035	2820
	Q		kW	-	31	91	166	219	219	215	219	219
	V	secondary	l/h	-	899	2638	4813	6350	6350	6234	6350	6350

T °C SUP/RET, Heating secondary	V - Flow rate, Q - Power		Units	District heating, primary								
				60 °C	65 °C	70 °C	75 °C	80 °C	85 °C	90 °C	95 °C	100 °C
55/30	V	primary	l/h	1251	3035	4167	3637	3267	2962	2655	2509	2336
	Q		kW	40	114	181	181	182	182	178	182	182
	V	secondary	l/h	1390	3963	6292	6292	6326	6326	6187	6326	6326
50/35	V	primary	l/h	3964	3236	2758	2412	2147	1937	1733	1624	1504
	Q		kW	109	109	109	109	109	109	107	109	109
	V	secondary	l/h	6315	6315	6315	6315	6315	6315	6199	6315	6315
50/30	V	primary	l/h	4523	3748	3239	2866	2578	2347	2111	1995	1859
	Q		kW	145	145	145	145	145	145	142	145	145
	V	secondary	l/h	6295	6295	6295	6295	6295	6295	6165	6295	6295
45/35	V	primary	l/h	2534	2111	1813	1590	1417	1279	1150	1072	993
	Q		kW	72	72	72	72	72	72	71	72	72
	V	secondary	l/h	6251	6251	6251	6251	6251	6251	6165	6251	6251
45/30	V	primary	l/h	3204	2728	2385	2122	1914	1745	1574	1485	1384
	Q		kW	108	108	108	108	108	108	106	108	108
	V	secondary	l/h	6246	6246	6246	6246	6246	6246	6130	6246	6246
40/30	V	primary	l/h	2106	1808	1586	1413	1275	1163	1040	990	923
	Q		kW	72	72	72	72	72	72	70	72	72
	V	secondary	l/h	6241	6241	6241	6241	6241	6241	6067	6241	6241

**Power data for D H409 11 and D H410 11**

- Pressure-independent control valve DN 40 1 **4406** 35 and strainer DN 50 1 **2662** 06 integrated in the primary side
- Max. return temperature efficiency: 2 K
- Max.  $\Delta p$  primary side / secondary side of the heat exchanger: 15 kPa
- Heat exchanger: 120 plates

T °C SUP/RET, Heating secondary	V - Flow rate, Q - Power		Units	District heating, primary								
				60 °C	65 °C	70 °C	75 °C	80 °C	85 °C	90 °C	95 °C	100 °C
95/70	V	primary	l/h	-	-	-	-	-	-	-	-	2617
	Q		kW	-	-	-	-	-	-	-	-	82
	V	secondary	l/h	-	-	-	-	-	-	-	-	2897
90/60	V	primary	l/h	-	-	-	-	-	-	-	1514	3744
	Q		kW	-	-	-	-	-	-	-	56	159
	V	secondary	l/h	-	-	-	-	-	-	-	1643	4666
85/60	V	primary	l/h	-	-	-	-	-	-	2349	5457	4996
	Q		kW	-	-	-	-	-	-	74	202	217
	V	secondary	l/h	-	-	-	-	-	-	2603	7105	7633
80/65	V	primary	l/h	-	-	-	-	-	6269	4728	3892	3331
	Q		kW	-	-	-	-	-	130	130	130	130
	V	secondary	l/h	-	-	-	-	-	7621	7621	7621	7621
80/60	V	primary	l/h	-	-	-	-	-	4089	5354	4486	3900
	Q		kW	-	-	-	-	-	106	173	173	173
	V	secondary	l/h	-	-	-	-	-	4656	5354	7598	7598
75/50	V	primary	l/h	-	-	-	-	2118	4892	4939	4334	3902
	Q		kW	-	-	-	-	67	182	215	215	216
	V	secondary	l/h	-	-	-	-	2118	6375	7531	7531	7566
70/55	V	primary	l/h	-	-	-	6241	4684	3847	3289	2881	2567
	Q		kW	-	-	-	129	129	129	129	129	129
	V	secondary	l/h	-	-	-	7531	7531	7531	7531	7531	7531
70/50	V	primary	l/h	-	-	-	3608	5324	4449	3861	3426	3087
	Q		kW	-	-	-	94	172	172	172	172	172
	V	secondary	l/h	-	-	-	4112	7523	7523	7523	7523	7523
65/40	V	primary	l/h	-	-	1858	4308	4890	4282	3832	3495	3207
	Q		kW	-	-	59	161	213	213	213	214	214
	V	secondary	l/h	-	-	2059	5617	7432	7432	7432	7467	7467
60/45	V	primary	l/h	-	6225	4645	3806	3250	2845	2534	2287	2085
	Q		kW	-	128	128	128	128	128	128	128	128
	V	secondary	l/h	-	7443	7443	7443	7443	7443	7443	7443	7443
60/40	V	primary	l/h	-	3093	5271	4390	3804	3372	3036	2765	2541
	Q		kW	-	81	170	170	170	170	170	170	170
	V	secondary	l/h	-	3529	7407	7407	7407	7407	7407	7407	7407
60/30	V	primary	l/h	-	985	2552	4149	4648	4181	3816	3518	3269
	Q		kW	-	37	110	202	254	254	254	254	254
	V	secondary	l/h	-	1073	3189	5857	7364	7364	7364	7364	7364

T °C SUP/RET, Heating secondary	V - Flow rate, Q - Power		Units	District heating, primary								
				60 °C	65 °C	70 °C	75 °C	80 °C	85 °C	90 °C	95 °C	100 °C
55/30	V	primary	l/h	1567	3701	4849	4236	3784	3432	3146	2909	2708
	Q		kW	50	139	211	211	211	211	211	211	211
	V	secondary	l/h	1738	4832	7335	7335	7335	7335	7335	7335	7335
50/35	V	primary	l/h	4574	3737	3213	2810	2501	2257	2057	1892	1752
	Q		kW	126	126	127	127	127	127	127	127	127
	V	secondary	l/h	7300	7300	7358	7358	7358	7358	7358	7358	7358
50/30	V	primary	l/h	5226	4336	3749	3319	2987	2718	2512	2325	2166
	Q		kW	168	168	168	168	168	168	169	169	169
	V	secondary	l/h	7293	7293	7293	7293	7293	7293	7337	7337	7337
45/35	V	primary	l/h	2955	2462	2114	1854	1653	1492	1360	1251	1159
	Q		kW	84	84	84	84	84	84	84	84	84
	V	secondary	l/h	7293	7293	7293	7293	7293	7293	7293	7293	7293
45/30	V	primary	l/h	3735	3182	2782	2476	2233	2036	1871	1733	1615
	Q		kW	126	126	126	126	126	126	126	126	126
	V	secondary	l/h	7287	7287	7287	7287	7287	7287	7287	7287	7287
40/30	V	primary	l/h	2428	2084	1828	1629	1470	1341	1247	1155	1076
	Q		kW	83	83	83	83	83	83	84	84	84
	V	secondary	l/h	7194	7194	7194	7194	7194	7194	7281	7281	7281

**Power data for D H409 12 and D H410 12**

- Pressure-independent control valve DN 40 1 **4406 35** and strainer DN 50 1 **2662 06** integrated in the primary side
- Max. return temperature efficiency: 2 K
- Max.  $\Delta p$  primary side / secondary side of the heat exchanger: 15 kPa
- Heat exchanger: 140 plates

T °C SUP/RET, Heating secondary	V - Flow rate, Q - Power		Units	District heating, primary								
				60 °C	65 °C	70 °C	75 °C	80 °C	85 °C	90 °C	95 °C	100 °C
95/70	V	primary	l/h	-	-	-	-	-	-	-	-	3096
	Q		kW	-	-	-	-	-	-	-	-	97
	V	secondary	l/h	-	-	-	-	-	-	-	-	3427
90/60	V	primary	l/h	-	-	-	-	-	-	-	1784	4378
	Q		kW	-	-	-	-	-	-	-	66	186
	V	secondary	l/h	-	-	-	-	-	-	-	1937	5458
85/60	V	primary	l/h	-	-	-	-	-	-	2761	6602	5609
	Q		kW	-	-	-	-	-	-	87	244	244
	V	secondary	l/h	-	-	-	-	-	-	3060	8582	8582
80/65	V	primary	l/h	-	-	-	-	-	7014	5304	4369	3740
	Q		kW	-	-	-	-	-	146	146	146	146
	V	secondary	l/h	-	-	-	-	-	8559	8559	8559	8559
80/60	V	primary	l/h	-	-	-	-	-	4823	6024	5051	4393
	Q		kW	-	-	-	-	-	125	195	195	195
	V	secondary	l/h	-	-	-	-	-	5490	8565	8565	8565
75/50	V	primary	l/h	-	-	-	-	2432	5724	5576	4895	4388
	Q		kW	-	-	-	-	77	213	243	243	243
	V	secondary	l/h	-	-	-	-	2697	7461	8512	8512	8512
70/55	V	primary	l/h	-	-	-	6989	5257	4322	3696	3238	2886
	Q		kW	-	-	-	145	145	145	145	145	145
	V	secondary	l/h	-	-	-	8465	8465	8465	8465	8465	8465
70/50	V	primary	l/h	-	-	-	4180	5993	5013	4353	3863	3481
	Q		kW	-	-	-	109	194	194	194	194	194
	V	secondary	l/h	-	-	-	4768	8486	8486	8486	8486	8486
65/40	V	primary	l/h	-	-	2205	5057	5501	4820	4333	3935	3611
	Q		kW	-	-	70	189	240	240	241	241	241
	V	secondary	l/h	-	-	2442	6594	8374	8374	8409	8409	8409
60/45	V	primary	l/h	-	6976	5217	4279	3655	3200	2850	2572	2346
	Q		kW	-	144	144	144	144	144	144	144	144
	V	secondary	l/h	-	8374	8374	8374	8374	8374	8374	8374	8374
60/40	V	primary	l/h	-	3626	5939	4953	4293	3807	3428	3122	2870
	Q		kW	-	95	192	192	192	192	192	192	192
	V	secondary	l/h	-	4139	8366	8366	8366	8366	8366	8366	8366
60/30	V	primary	l/h	-	1172	3016	4868	5244	4720	4308	3973	3692
	Q		kW	-	44	130	237	287	287	287	287	287
	V	secondary	l/h	-	1276	3769	6872	8321	8321	8321	8321	8321

T °C SUP/RET, Heating secondary	V - Flow rate, Q - Power		Units	District heating, primary								
				60 °C	65 °C	70 °C	75 °C	80 °C	85 °C	90 °C	95 °C	100 °C
55/30	V	primary	l/h	1849	4368	5459	4772	4265	3869	3548	3280	3054
	Q		kW	59	164	238	238	238	238	238	238	238
	V	secondary	l/h	2051	5701	8273	8273	8273	8273	8273	8273	8273
50/35	V	primary	l/h	5183	4238	3616	3163	2817	2541	2316	2130	1973
	Q		kW	143	143	143	143	143	143	143	143	143
	V	secondary	l/h	8285	8285	8285	8285	8285	8285	8285	8285	8285
50/30	V	primary	l/h	5561	4898	4237	3753	3377	3074	2824	2614	2435
	Q		kW	179	190	190	190	190	190	190	188	190
	V	secondary	l/h	7771	8248	8248	8248	8248	8248	8248	8248	8248
45/35	V	primary	l/h	3342	2784	2391	2097	1869	1687	1539	1415	1310
	Q		kW	95	95	95	95	95	95	95	95	95
	V	secondary	l/h	8248	8248	8248	8248	8248	8248	8248	8248	8248
45/30	V	primary	l/h	4205	3584	3135	2790	2517	2294	2109	1953	1820
	Q		kW	142	142	142	142	142	142	142	142	142
	V	secondary	l/h	8212	8212	8212	8212	8212	8212	8212	8212	8212
40/30	V	primary	l/h	2749	2361	2070	1845	1665	1518	1396	1293	1205
	Q		kW	94	94	94	94	94	94	94	94	94
	V	secondary	l/h	8147	8147	8147	8147	8147	8147	8147	8147	8147

**Power data for D H409 13 and D H410 13**

- Pressure-independent control valve DN 50 1 **4406 36** and strainer DN 50 1 **2662 06** integrated in the primary side
- Max. return temperature efficiency: 2 K
- Max.  $\Delta p$  primary side / secondary side of the heat exchanger: 15 kPa
- Heat exchanger: 160 plates

T °C SUP/RET, Heating secondary	V - Flow rate, Q - Power		Units	District heating, primary								
				60 °C	65 °C	70 °C	75 °C	80 °C	85 °C	90 °C	95 °C	100 °C
95/70	V	primary	l/h	-	-	-	-	-	-	-	-	3542
	Q		kW	-	-	-	-	-	-	-	-	111
	V	secondary	l/h	-	-	-	-	-	-	-	-	3922
90/60	V	primary	l/h	-	-	-	-	-	-	-	2026	5014
	Q		kW	-	-	-	-	-	-	-	75	213
	V	secondary	l/h	-	-	-	-	-	-	-	2201	6250
85/60	V	primary	l/h	-	-	-	-	-	-	3174	7261	6176
	Q		kW	-	-	-	-	-	-	100	269	269
	V	secondary	l/h	-	-	-	-	-	-	3517	9462	9462
80/65	V	primary	l/h	-	-	-	-	-	7714	5843	4816	4123
	Q		kW	-	-	-	-	-	161	161	161	161
	V	secondary	l/h	-	-	-	-	-	9438	9438	9438	9438
80/60	V	primary	l/h	-	-	-	-	-	5433	6596	5538	4819
	Q		kW	-	-	-	-	-	141	214	214	214
	V	secondary	l/h	-	-	-	-	-	6193	9399	9399	9399
75/50	V	primary	l/h	-	-	-	-	2812	6584	6115	5373	4818
	Q		kW	-	-	-	-	89	245	267	267	267
	V	secondary	l/h	-	-	-	-	3117	8582	9352	9352	9352
70/55	V	primary	l/h	-	-	-	7687	5794	4767	4077	3573	3184
	Q		kW	-	-	-	160	160	160	160	160	160
	V	secondary	l/h	-	-	-	9341	9341	9341	9341	9341	9341
70/50	V	primary	l/h	-	-	-	4792	6566	5497	4776	4240	3821
	Q		kW	-	-	-	125	213	213	213	213	213
	V	secondary	l/h	-	-	-	5468	9317	9317	9317	9317	9317
65/40	V	primary	l/h	-	-	2453	5776	6064	5317	4762	4325	3969
	Q		kW	-	-	78	216	265	265	265	265	265
	V	secondary	l/h	-	-	2721	7536	9246	9246	9246	9246	9246
60/45	V	primary	l/h	-	7678	5754	4721	4034	3533	3147	2840	2590
	Q		kW	-	159	159	159	159	159	159	159	159
	V	secondary	l/h	-	9246	9246	9246	9246	9246	9246	9246	9246
60/40	V	primary	l/h	-	4161	6512	5436	4715	4182	3766	3431	3154
	Q		kW	-	109	211	211	211	211	211	211	211
	V	secondary	l/h	-	4749	9194	9194	9194	9194	9194	9194	9194
60/30	V	primary	l/h	-	1331	3384	5565	5765	5192	4741	4372	4065
	Q		kW	-	50	146	271	316	316	316	316	316
	V	secondary	l/h	-	1450	4233	7857	9162	9162	9162	9162	9162

T °C SUP/RET, Heating secondary	V - Flow rate, Q - Power		Units	District heating, primary								
				60 °C	65 °C	70 °C	75 °C	80 °C	85 °C	90 °C	95 °C	100 °C
55/30	V	primary	l/h	2065	4950	5998	5247	4692	4258	3904	3624	3374
	Q		kW	66	186	262	262	262	262	262	263	263
	V	secondary	l/h	2294	6466	9107	9107	9107	9107	9107	9107	9142
50/35	V	primary	l/h	5681	4650	3969	3473	3092	2789	2543	2338	2166
	Q		kW	157	157	157	157	157	157	157	157	157
	V	secondary	l/h	9096	9096	9096	9096	9096	9096	9096	9096	9096
50/30	V	primary	l/h	6469	5380	4657	4126	3713	3381	3106	2875	2679
	Q		kW	209	209	209	209	209	209	209	209	209
	V	secondary	l/h	9073	9073	9073	9073	9073	9073	9073	9073	9073
45/35	V	primary	l/h	3656	3048	2617	2296	2046	1847	1684	1549	1435
	Q		kW	104	104	104	104	104	104	104	104	104
	V	secondary	l/h	9030	9030	9030	9030	9030	9030	9030	9030	9030
45/30	V	primary	l/h	4616	3936	3443	3065	2765	2536	2332	2159	2012
	Q		kW	156	156	156	156	156	157	157	157	157
	V	secondary	l/h	9022	9022	9022	9022	9022	9080	9080	9080	9080
40/30	V	primary	l/h	3041	2611	2290	2041	1842	1680	1544	1430	1333
	Q		kW	104	104	104	104	104	104	104	104	104
	V	secondary	l/h	9014	9014	9014	9014	9014	9014	9014	9014	9014

Pressure loss diagrams D H409 06 and D H410 06

**District heating primary**

dp pressure-independent control valve DN32, Strainer DN40, pipes DN40, fittings and heat exchanger 60 plates, without heat meter

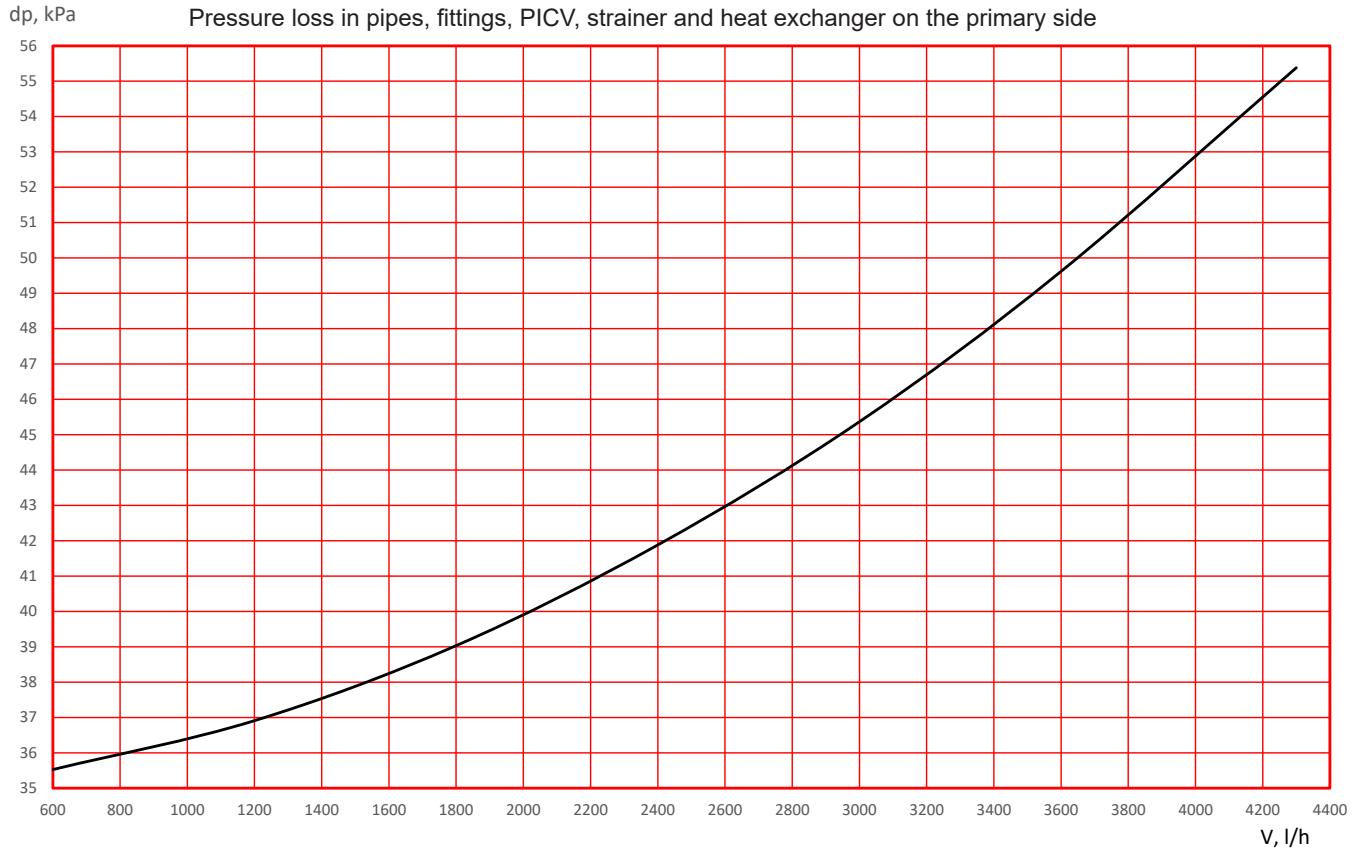

**District heating secondary**

dp pipes DN40, fittings and heat exchanger 60 plates

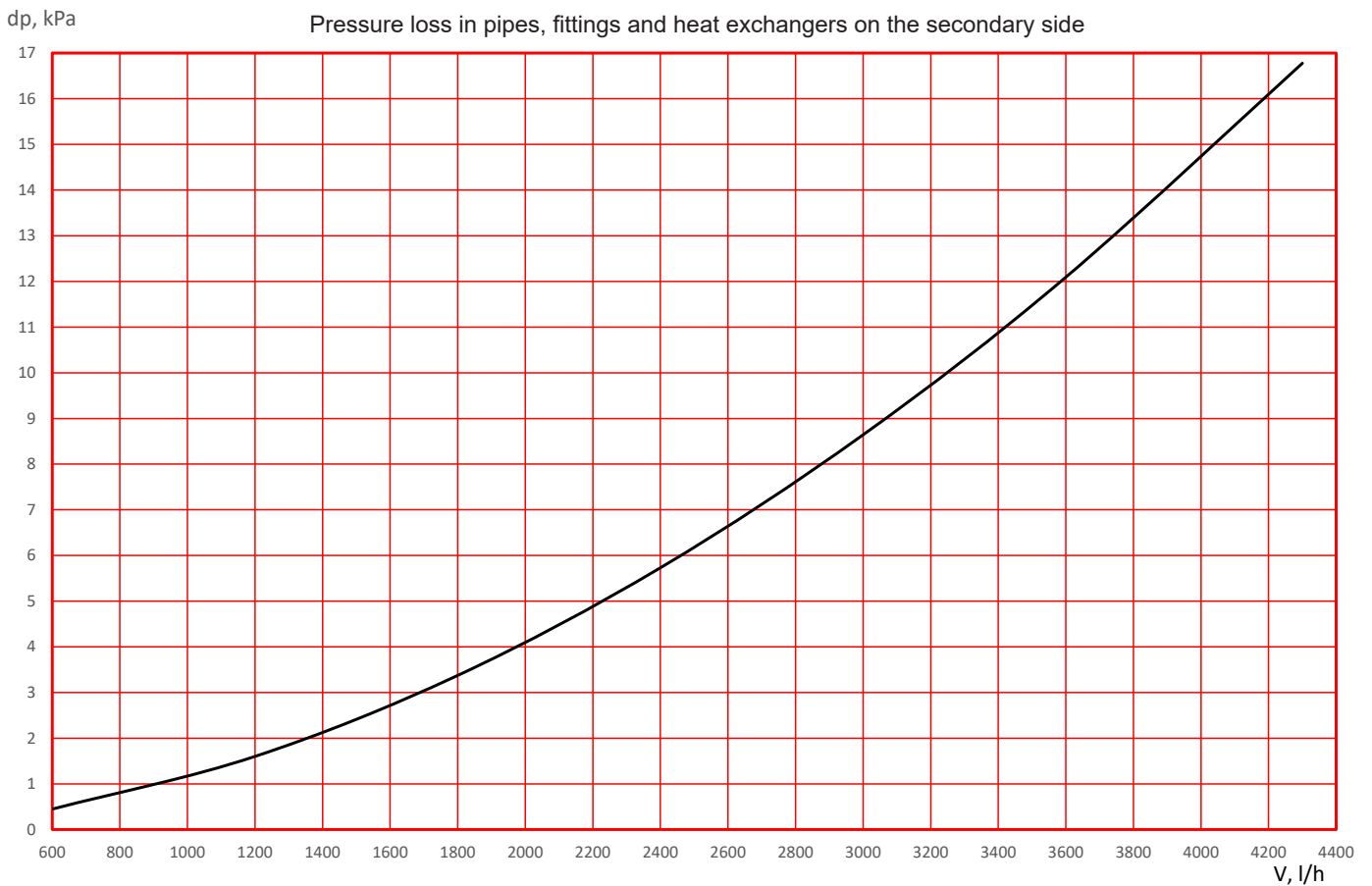

**Pressure loss diagrams D H409 07 and D H410 07**

**District heating primary**

dp pressure-independent control valve DN32, strainer DN40, pipes DN40, fittings and heat exchanger 70 plates, without heat meter

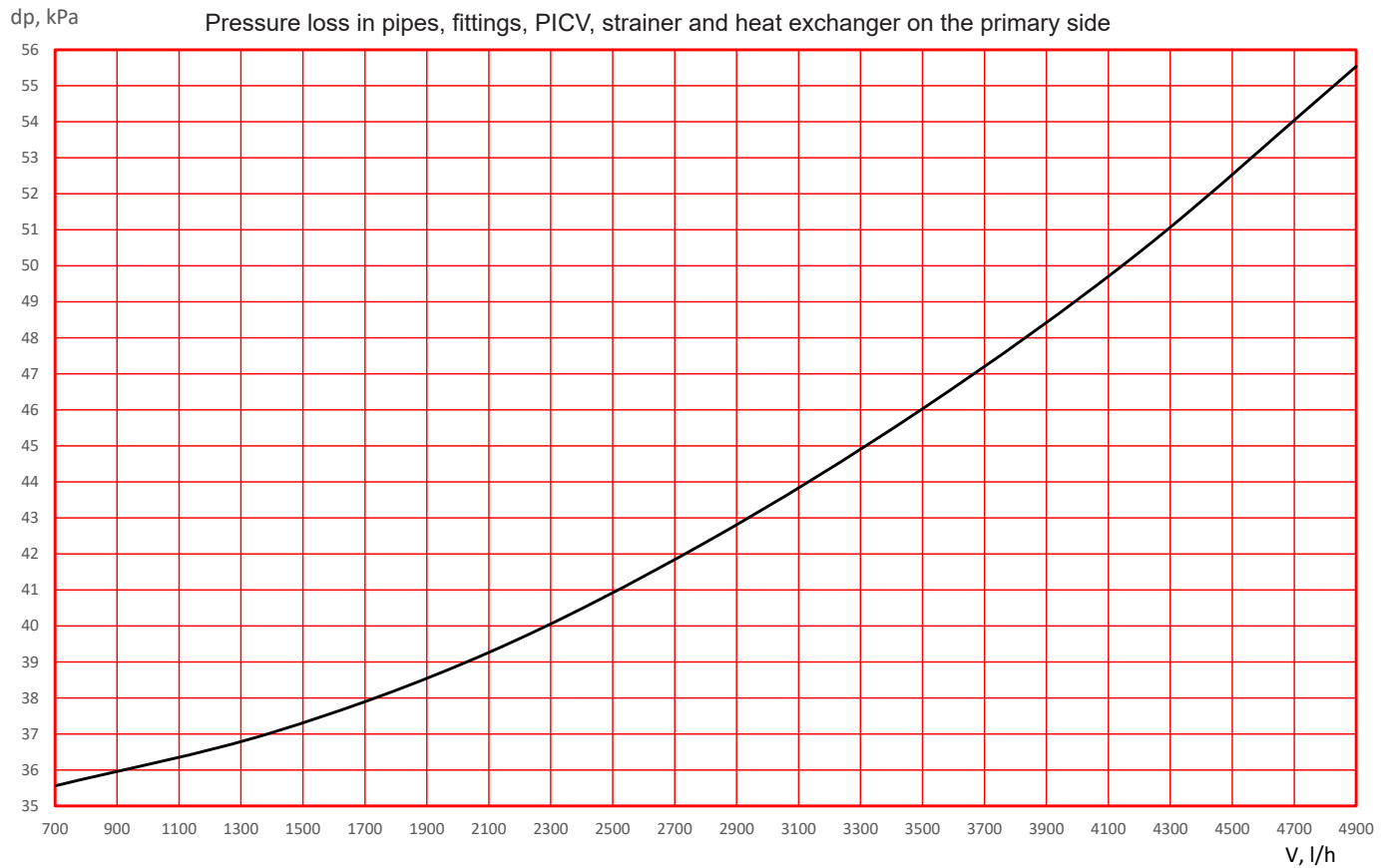

**District heating secondary**

dp pipes DN40, fittings and heat exchanger 70 plates

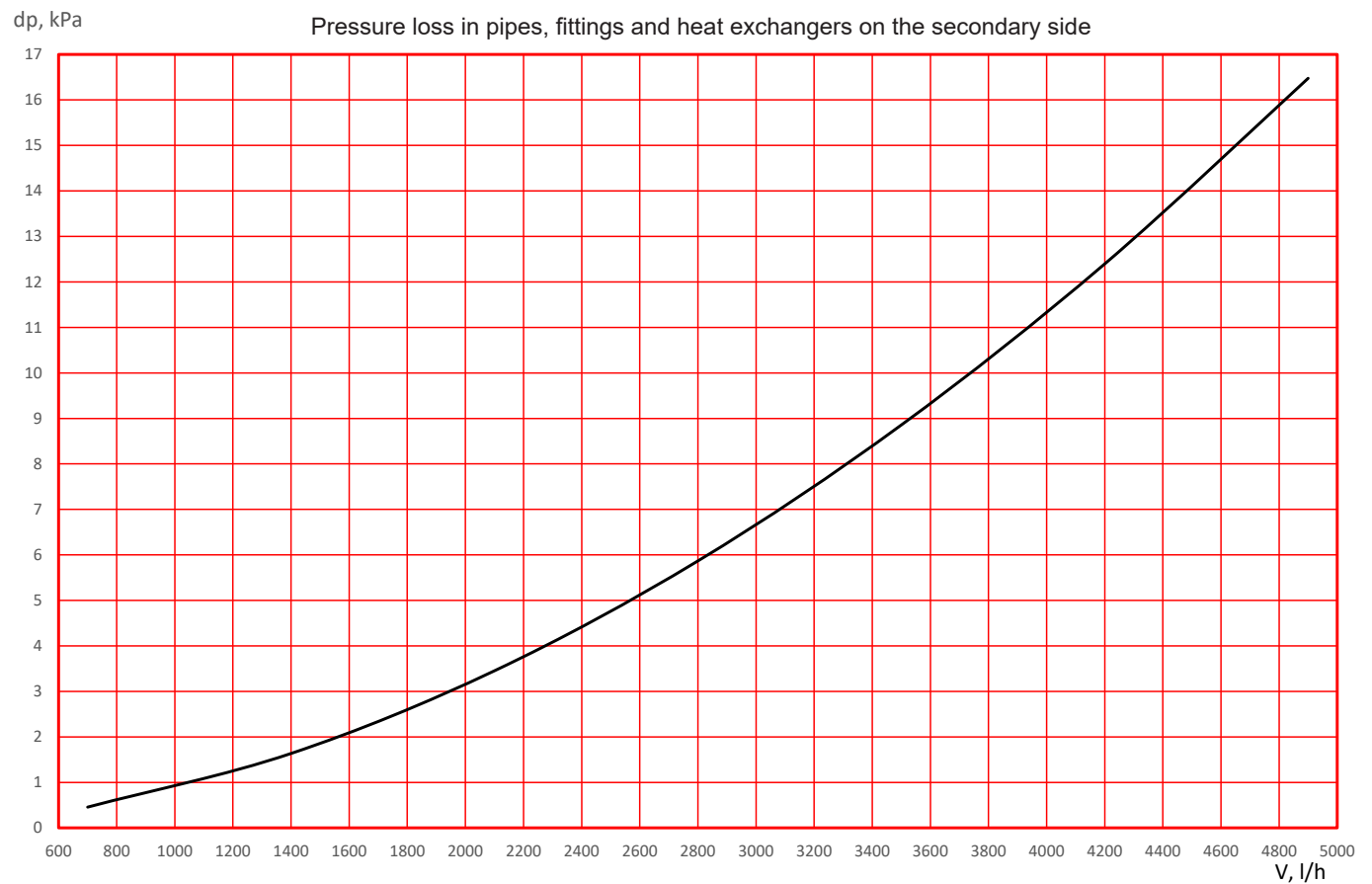

Pressure loss diagrams D H409 08 and D H410 08

**District heating primary**

dp pressure-independent control valve DN32, strainer DN40, pipes DN40, fittings and heat exchanger 80 plates, without heat meter

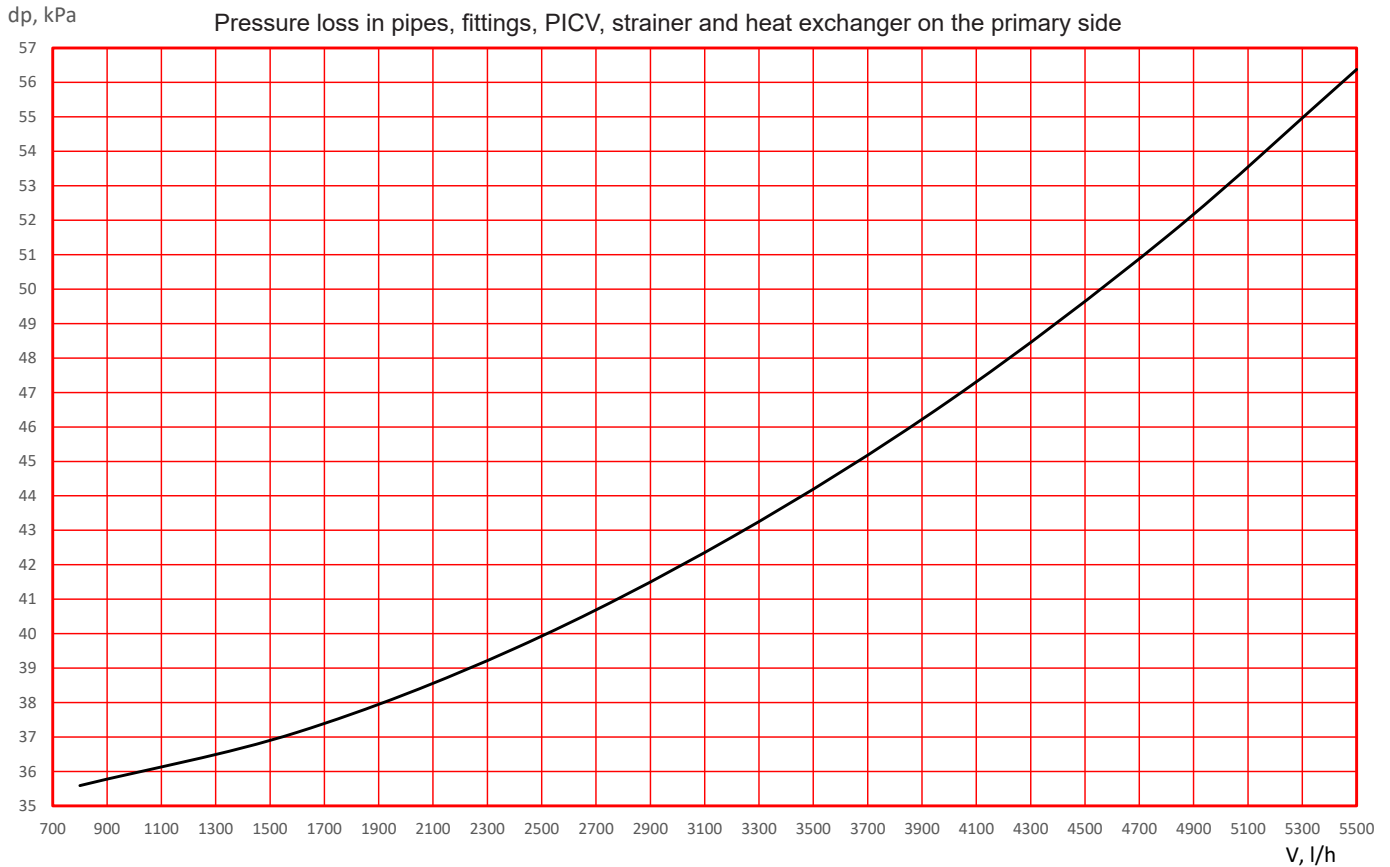

**District heating secondary**

dp pipes DN40, fittings and heat exchanger 80 plates

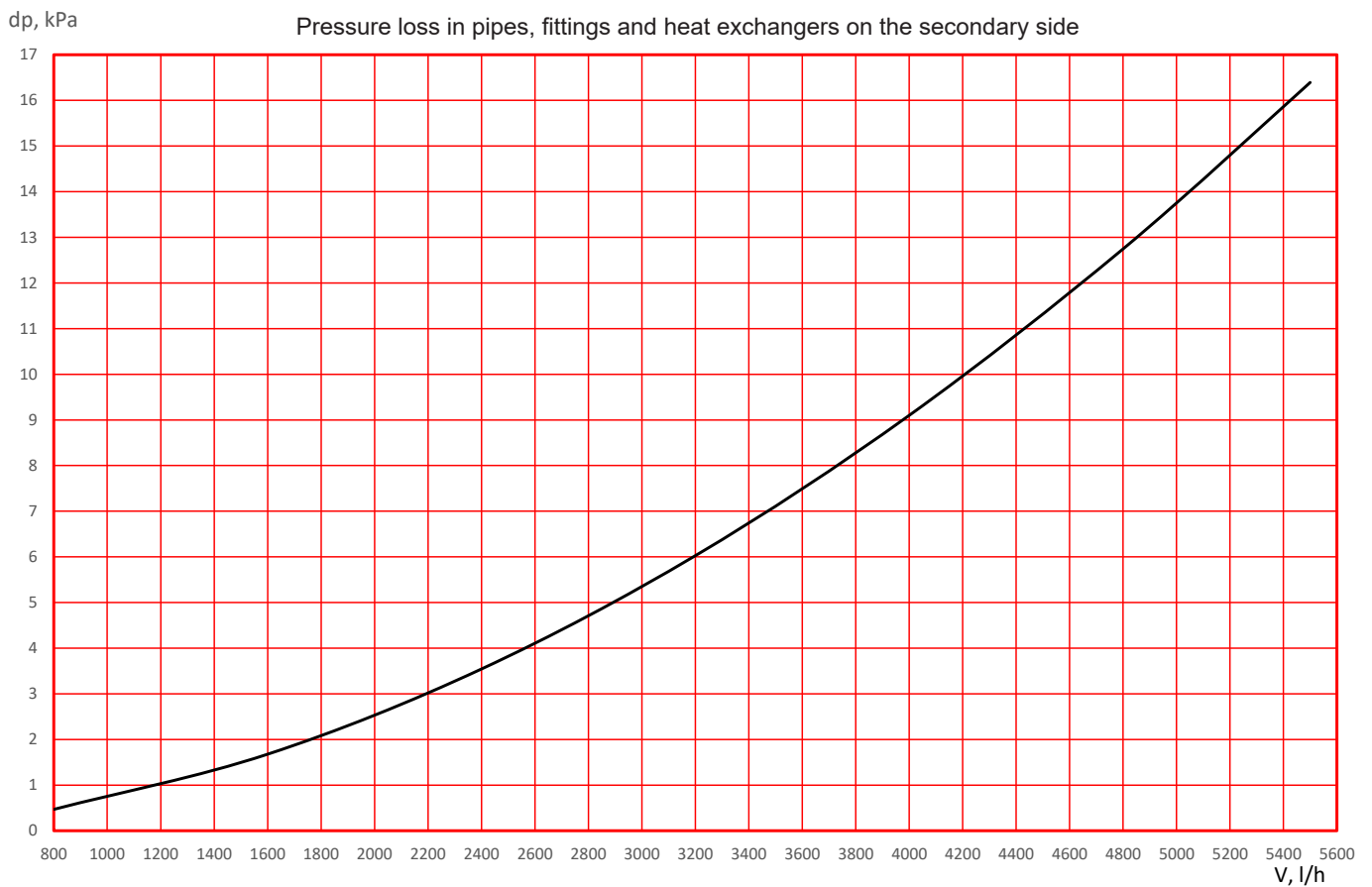

**Pressure loss diagrams D H409 09 and D H410 09**

**District heating primary**

dp pressure-independent control valve DN32, strainer DN50, pipes DN50, fittings and heat exchanger 90 plates, without heat meter

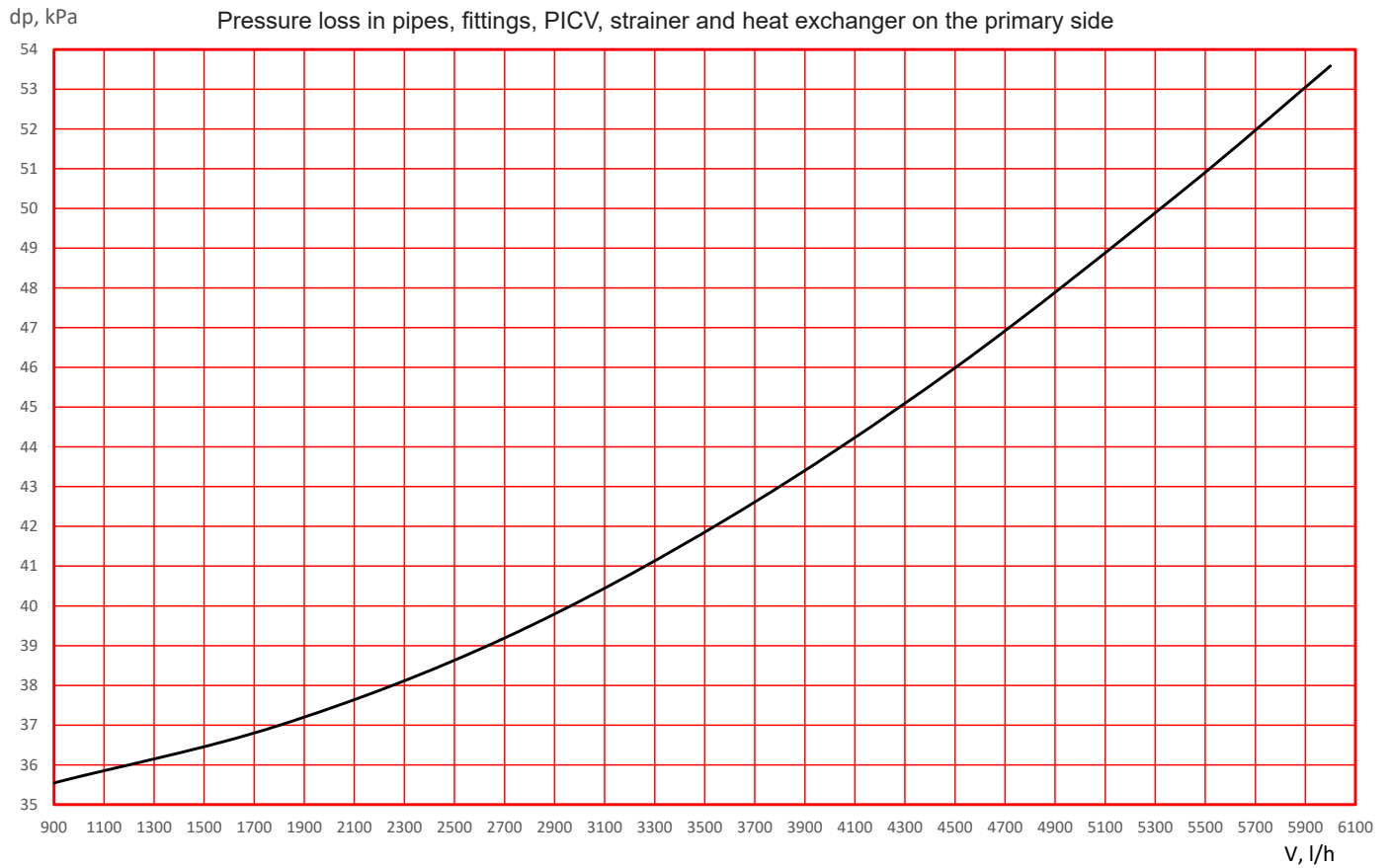

**District heating secondary**

dp pipes DN50, fittings and heat exchanger 90 plates

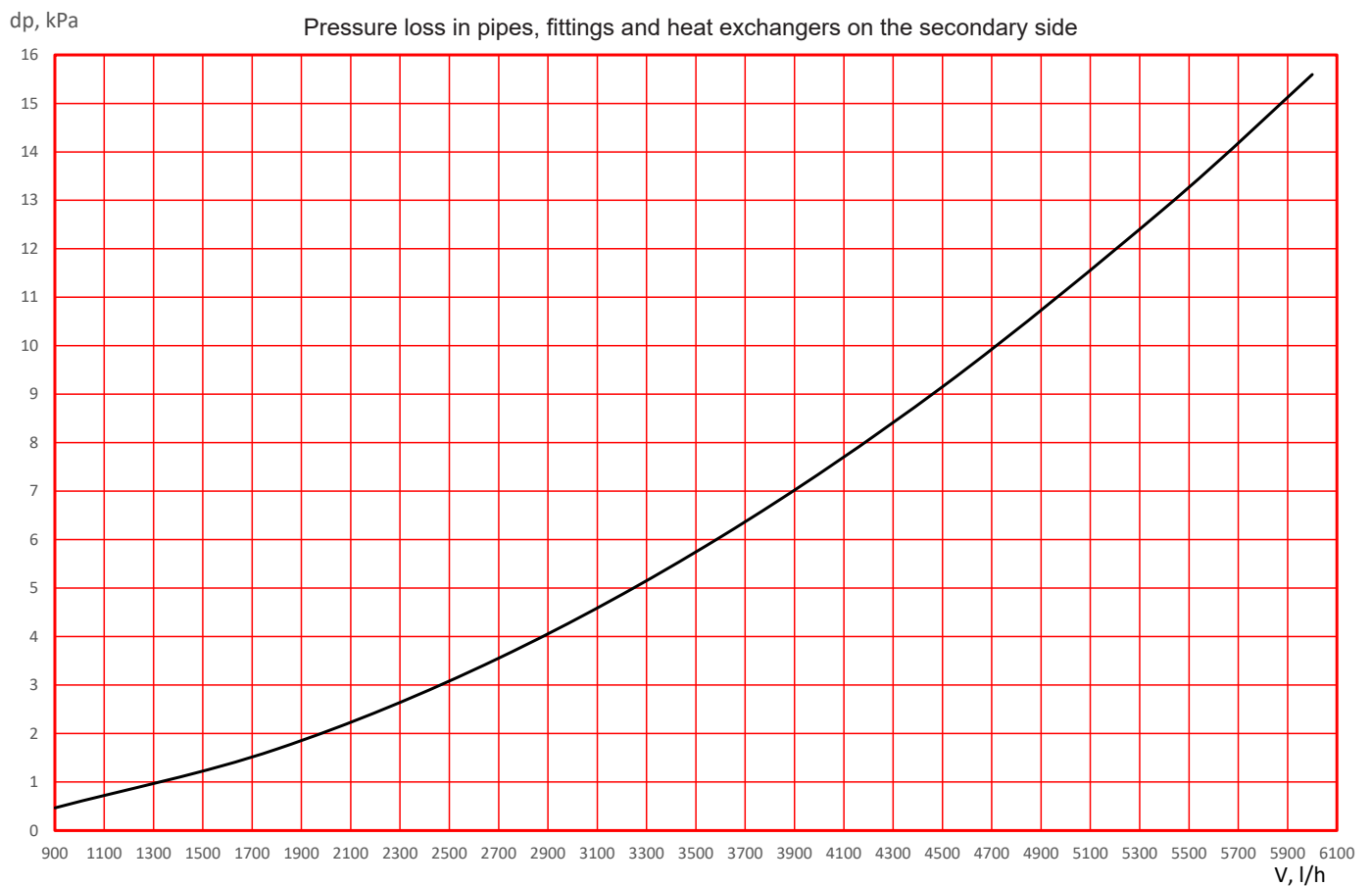

**Pressure loss diagrams D H409 10 and D H410 10**

**District heating primary**

dp pressure-independent control valve DN40, strainer DN50, pipes DN50, fittings and heat exchanger 100 plates, without heat meter

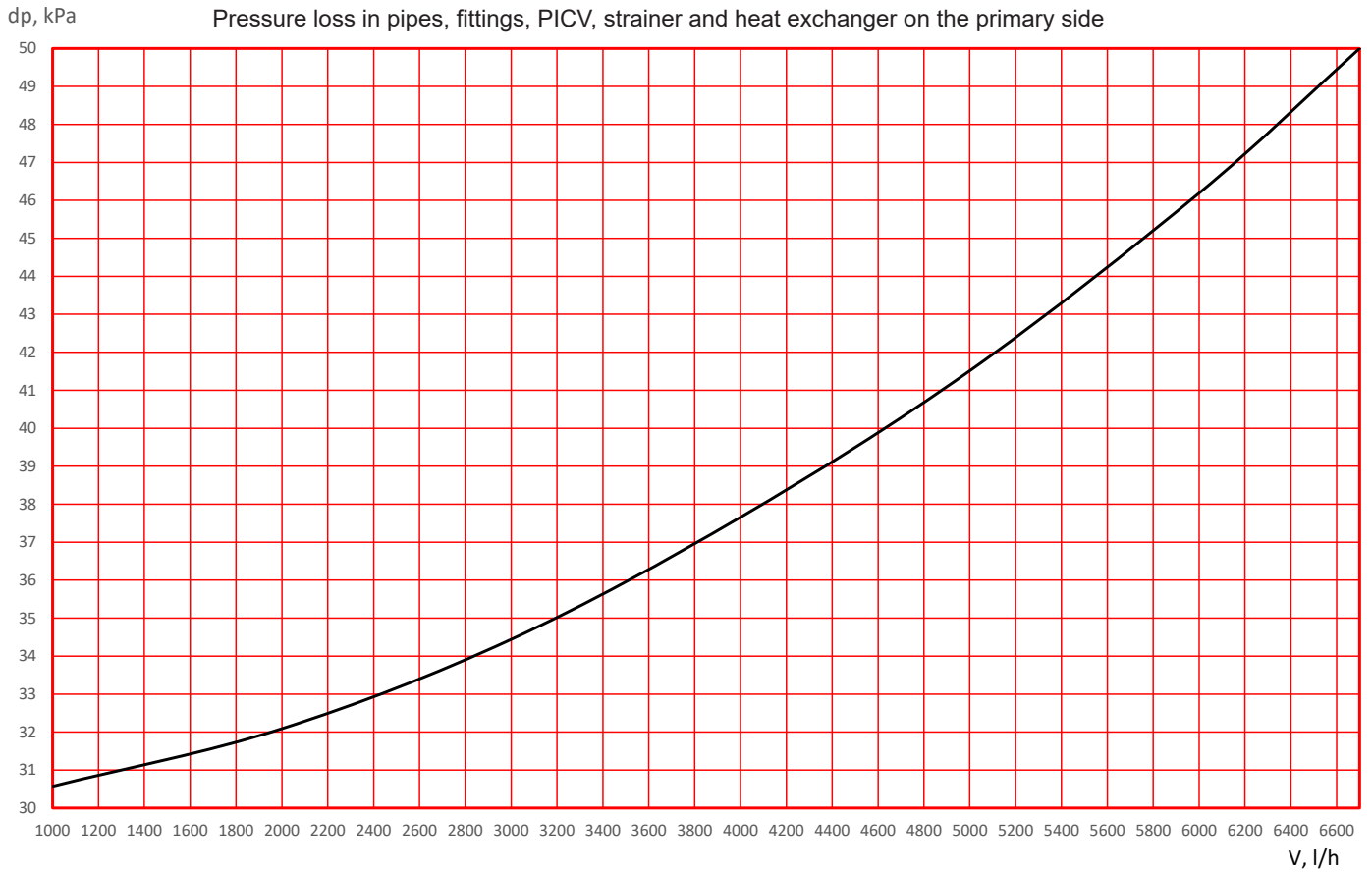

**District heating secondary**

dp pipes DN50, fittings and heat exchanger 100 plates

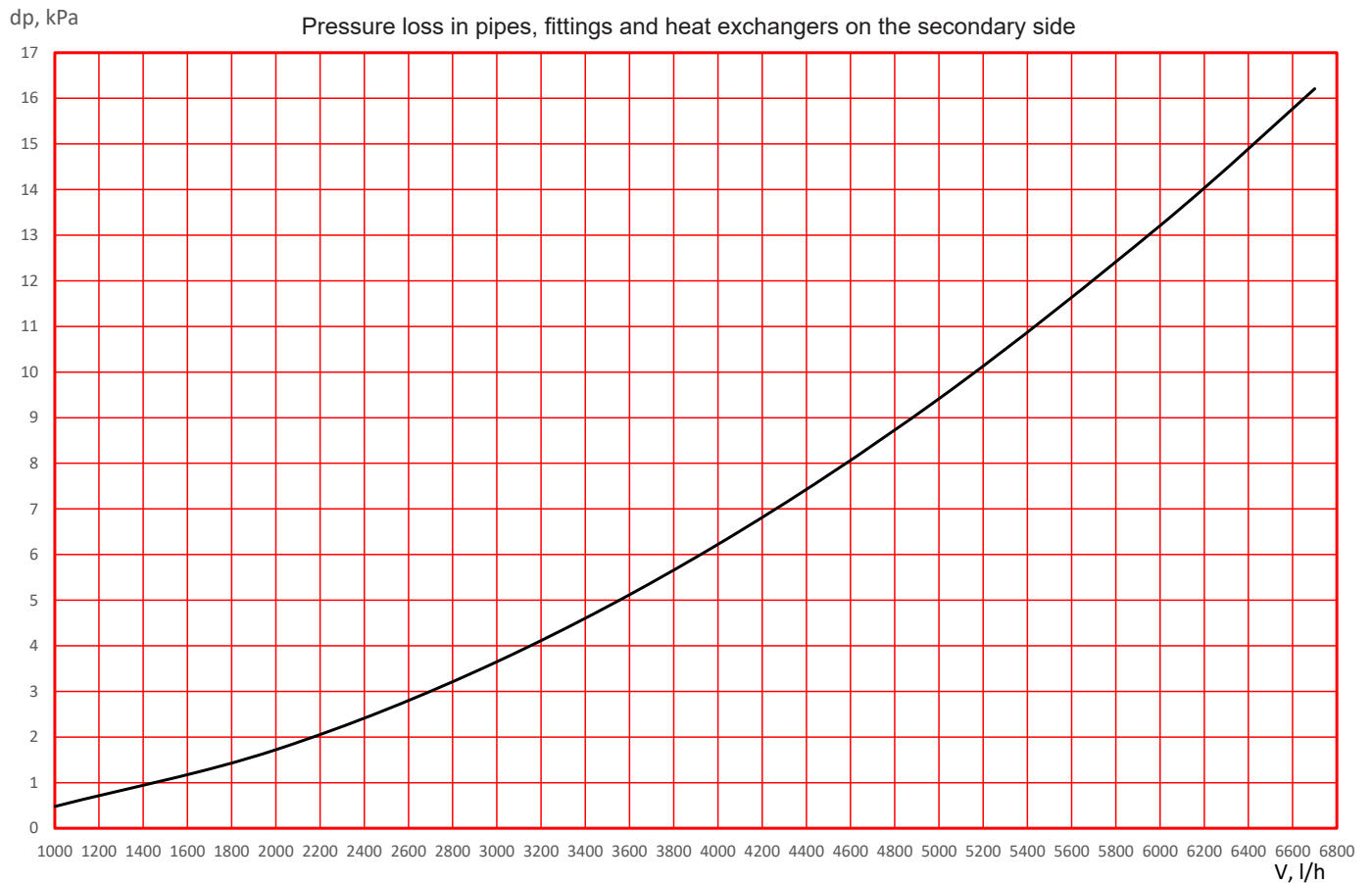

Pressure loss diagrams D H409 11 and D H410 11

**District heating primary**

dp pressure-independent control valve DN40, strainer DN50, pipes DN50, fittings and heat exchanger 120 Plates, without heat meter

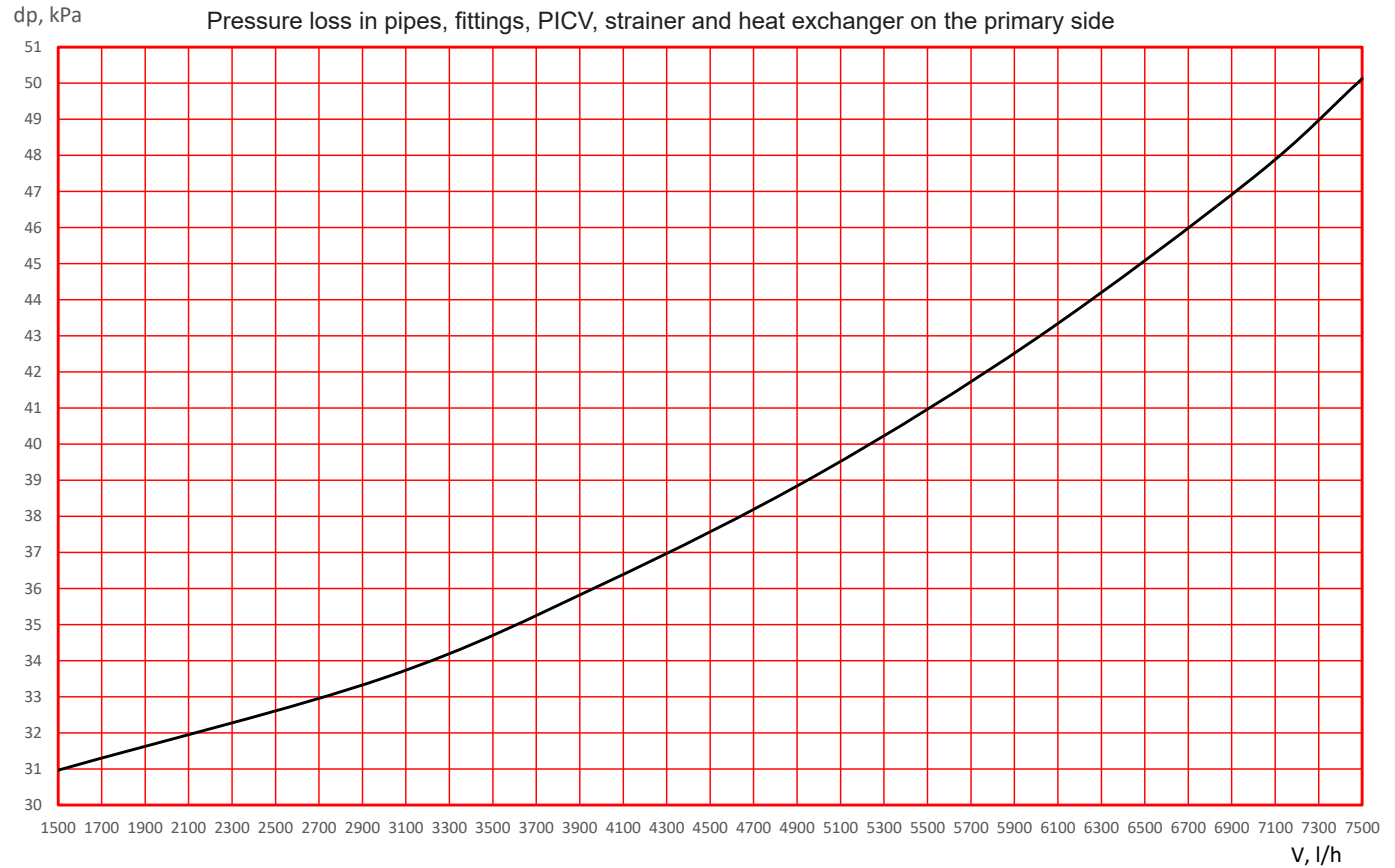

**District heating secondary**

dp pipes DN50, fittings and heat exchanger 120 plates

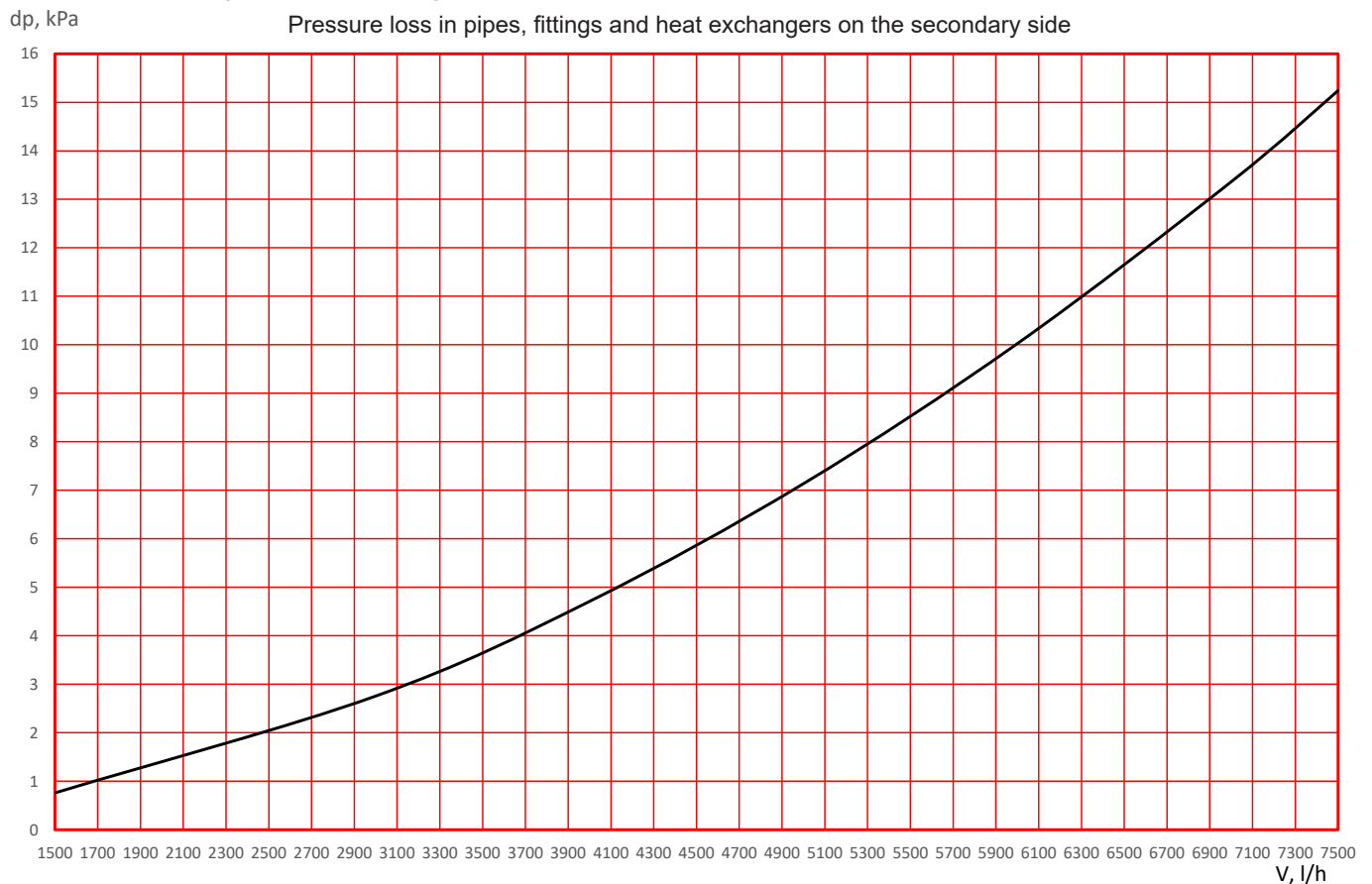

Pressure loss diagrams D H409 12 and D H410 12

**District heating primary**

dp Pressure-independent control valve DN40, strainer DN50, Pipes DN50, fittings and heat exchanger 140 plates, without heat meter

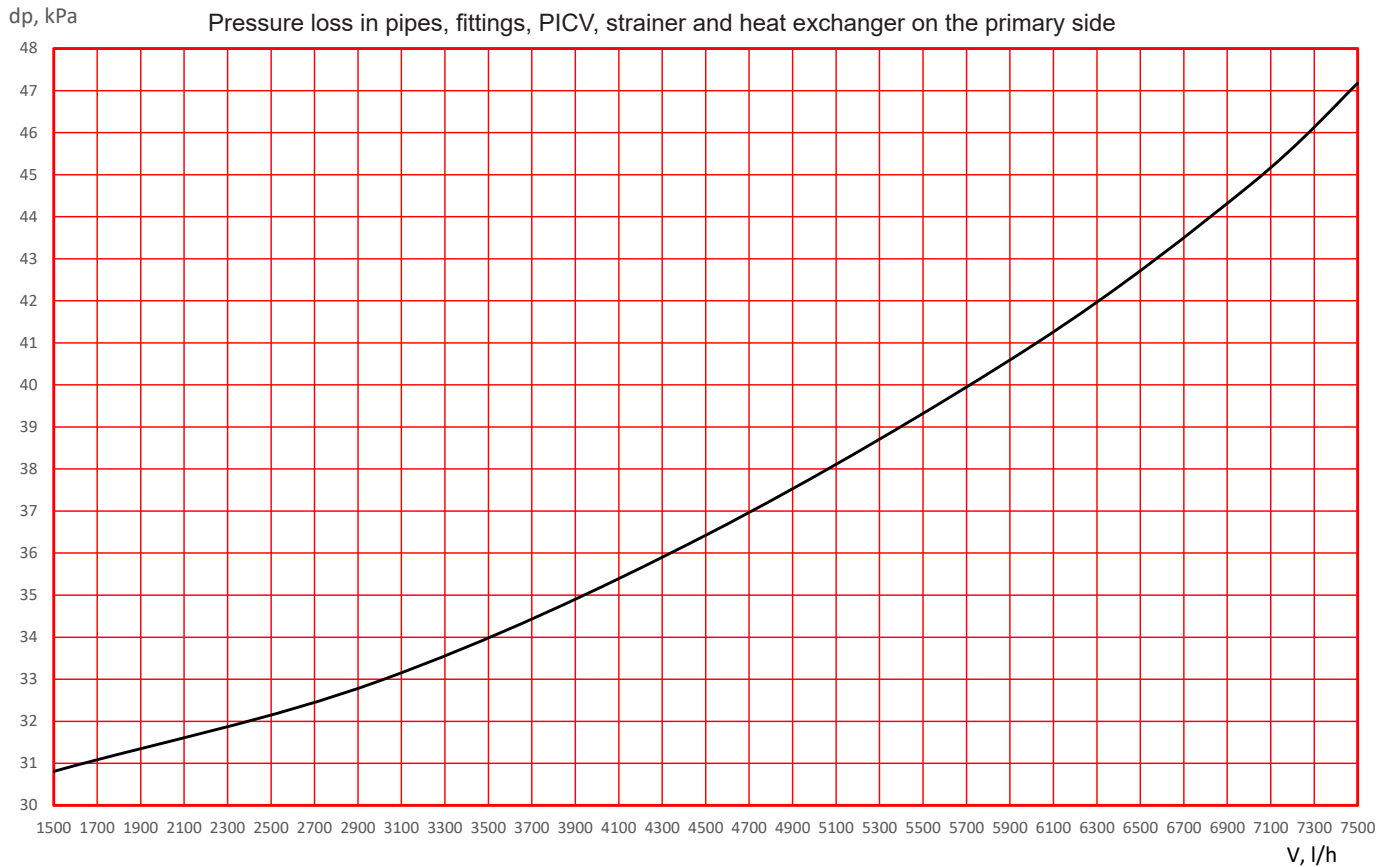

**District heating secondary**

dp pipes DN50, fittings and heat exchanger 140 plates

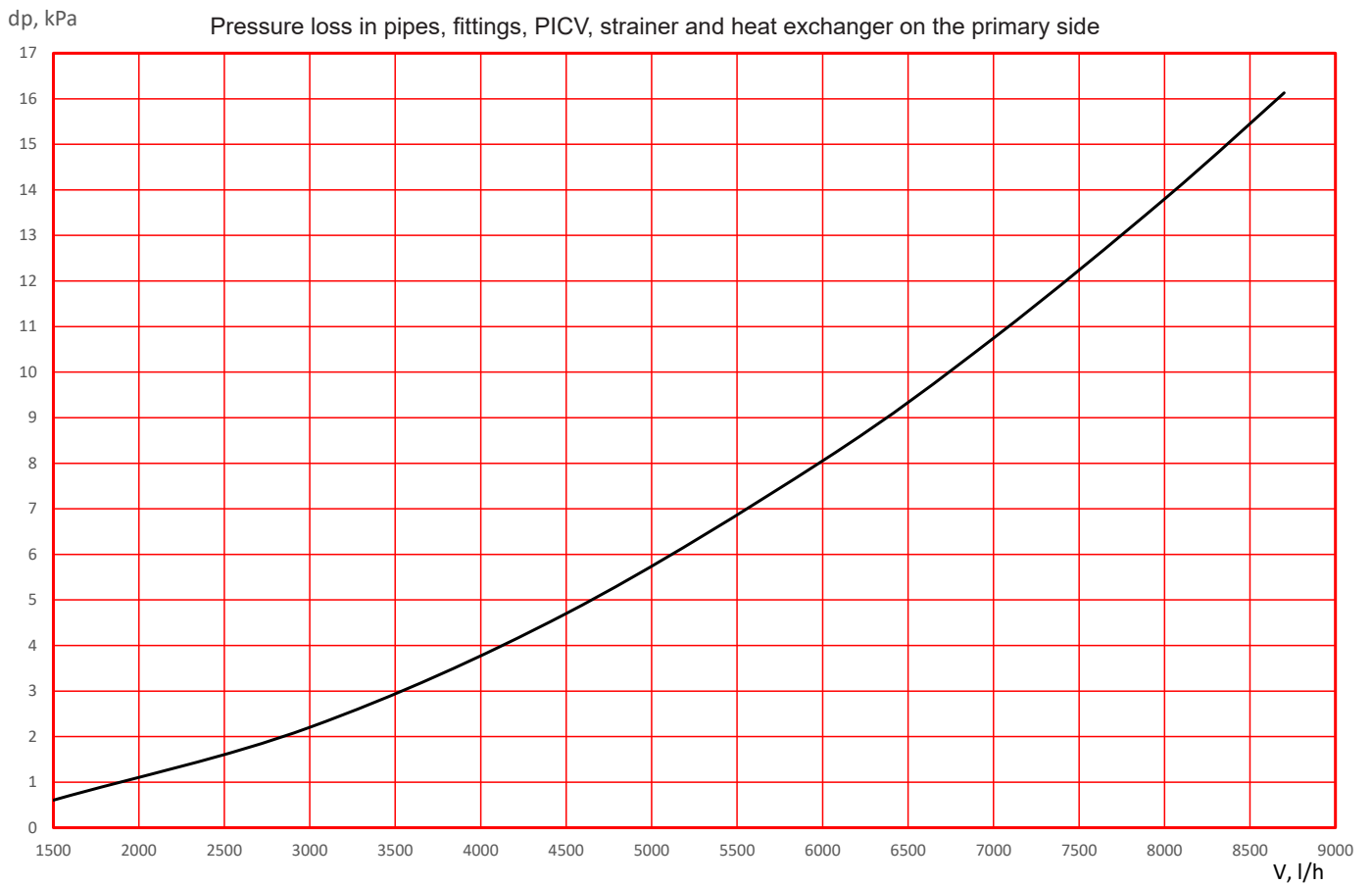

Pressure loss diagrams D H409 13 and D H410 13

**District heating primary**

dp pressure-independent control valve DN50, strainer DN50, pipes DN50, fittings and heat exchanger 160 plates, without heat meter

dp, kPa

Pressure loss in pipes, fittings, PICV, strainer and heat exchanger on the primary side

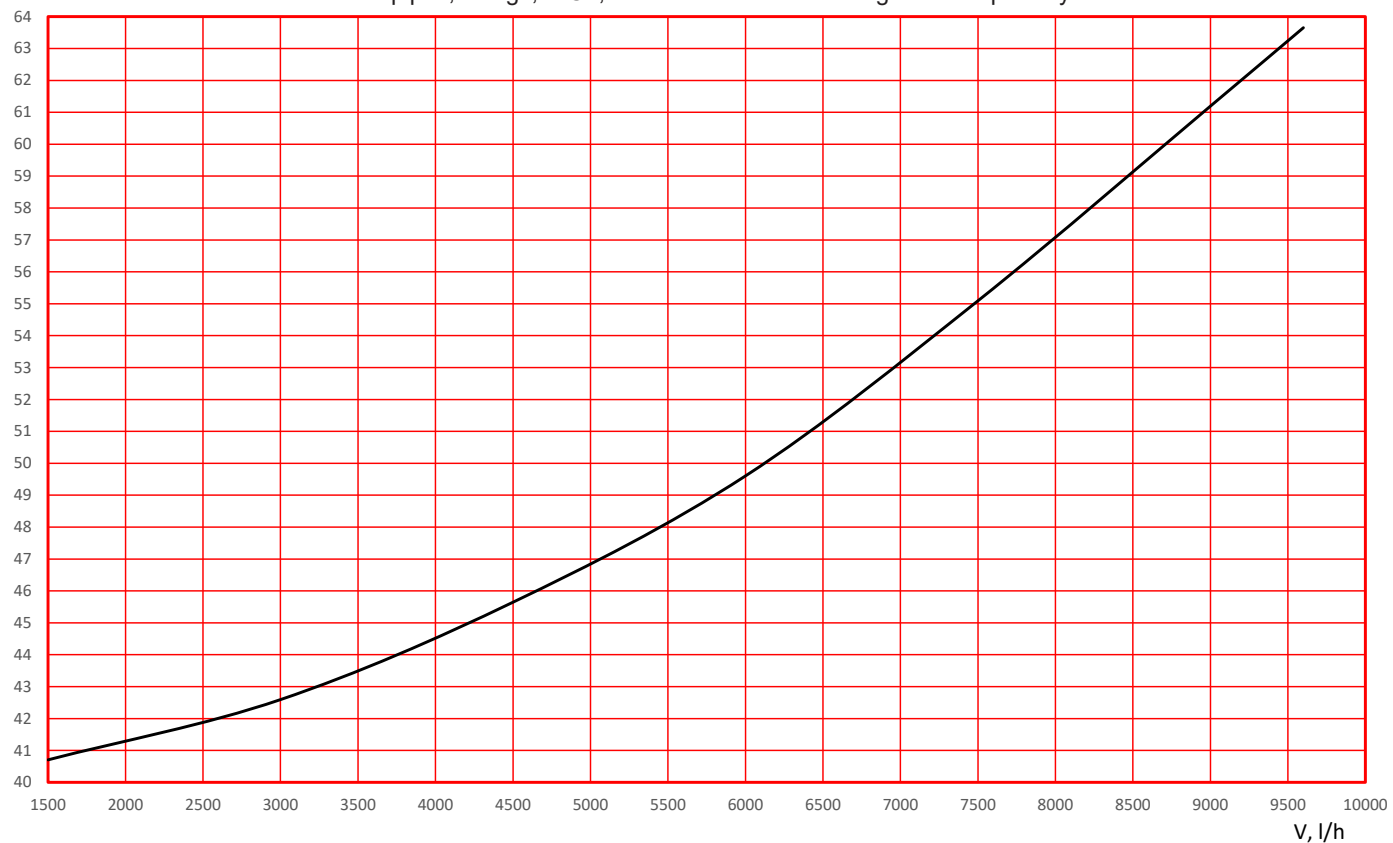

**District heating secondary**

dp pipes DN50, fittings and heat exchanger 160 plates

dp, kPa

Pressure loss in pipes, fittings and heat exchangers on the secondary side

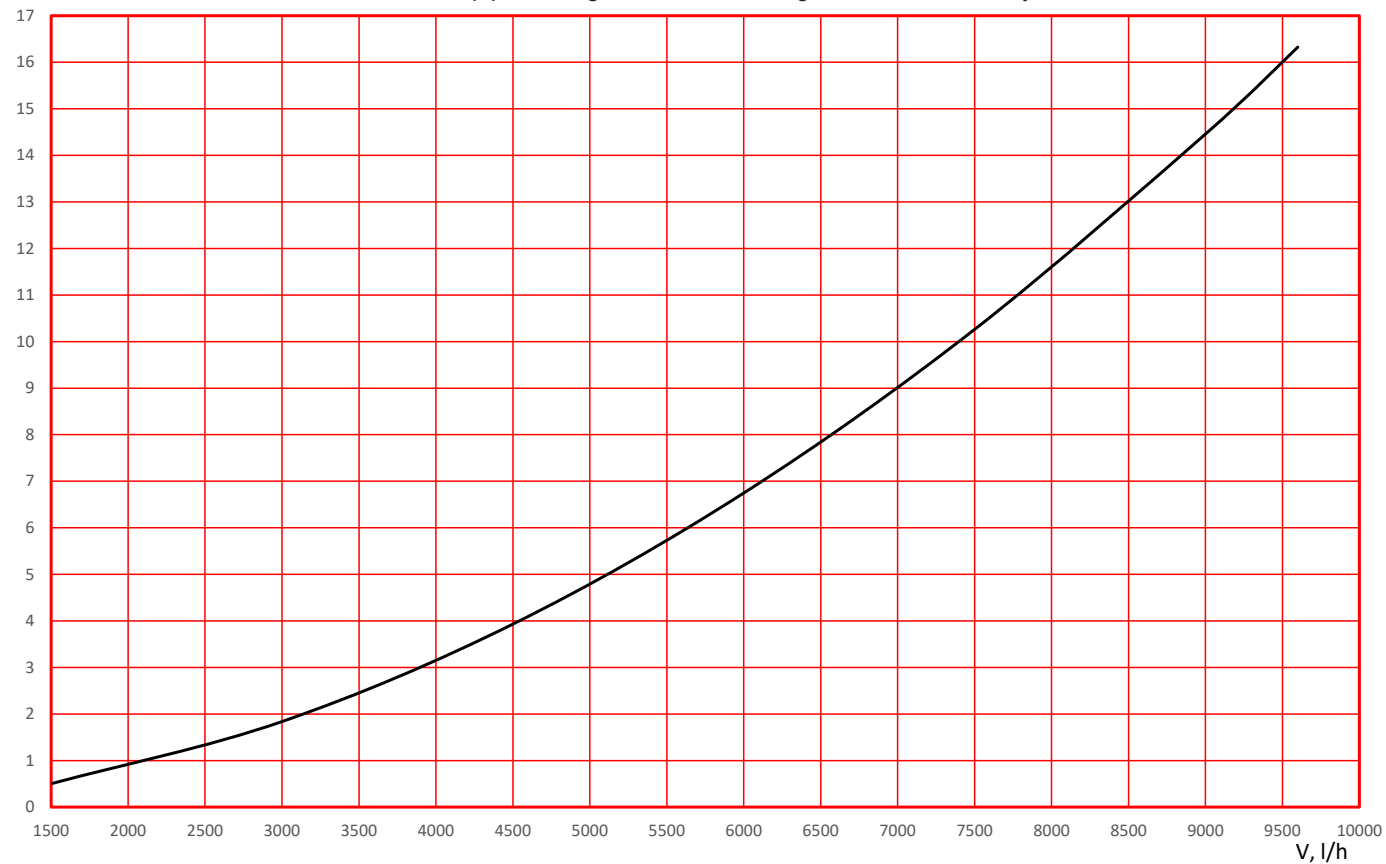

**HERZ pressure-independent control valve 4406**

N	Description	Materials
1	Body	DZR brass
2	Membrane body	brass
3	Pin	stainless steel
4	Membrane	EPDM
5	O-rings	EPDM
6	Spring	stainless steel
7	capillary pipe	copper Cu-DHP
8	Pin	stainless steel
9	Spring	stainless steel
10	Protective cap	plastic

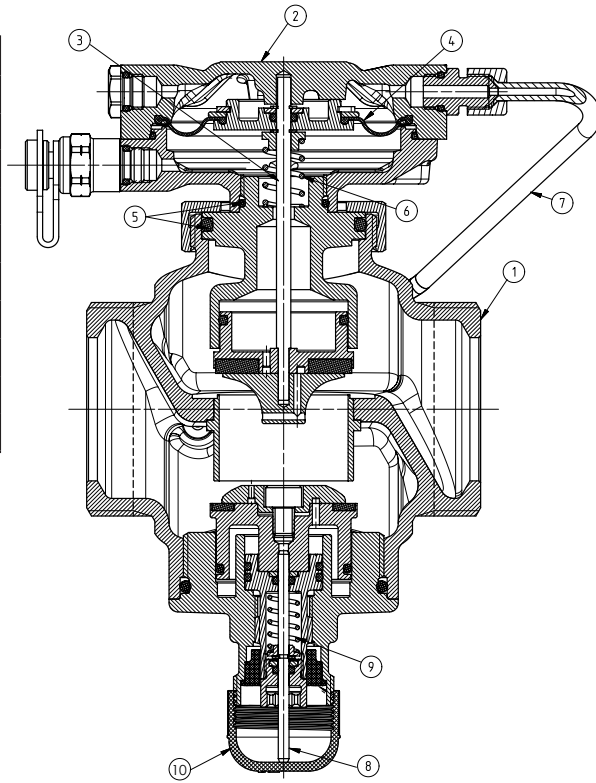

With the help of the kv diagram, the respective minimum differential pressure [kPa] can be determined depending on the flow [l/h] and the default setting [%].

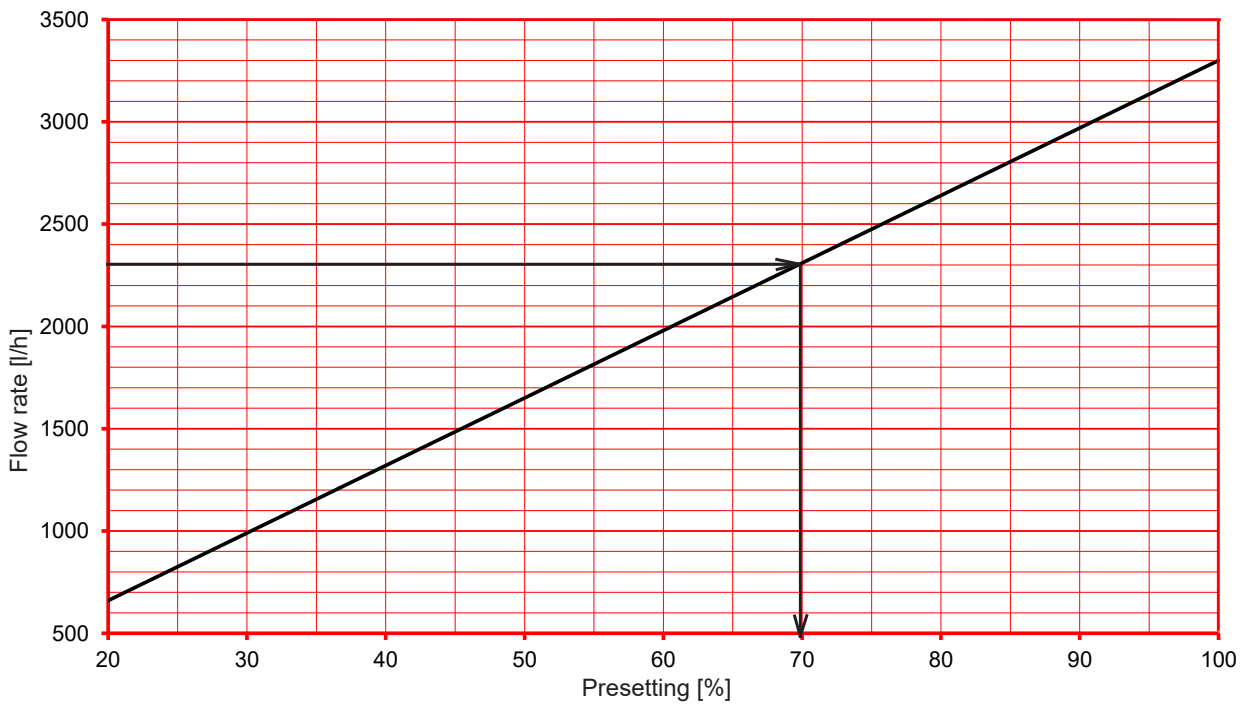

☑  $k_v$  - values of the control valve in the PIBCV (test points P1 - P2)

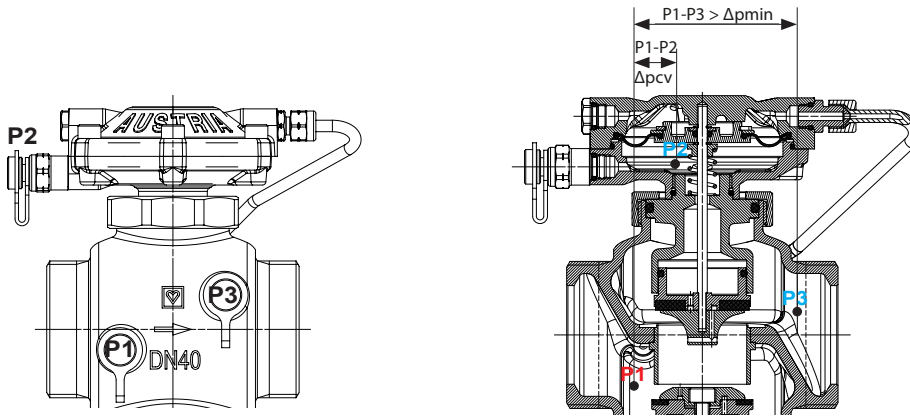

Presetting	DN32	DN 40	DN 50
[%]	[m <sup>3</sup> /h]	[m <sup>3</sup> /h]	[m <sup>3</sup> /h]
10	1,014	1,268	2,000
11	1,119	1,395	2,212
12	1,223	1,521	2,423
13	1,327	1,648	2,635
14	1,432	1,775	2,846
15	1,536	1,902	3,058
16	1,640	2,028	3,270
17	1,745	2,155	3,481
18	1,849	2,282	3,693
19	1,954	2,409	3,904
20	2,058	2,535	4,116
21	2,161	2,668	4,322
22	2,264	2,800	4,528
23	2,367	2,932	4,733
24	2,470	3,065	4,939
25	2,572	3,197	5,145
26	2,675	3,329	5,351
27	2,778	3,462	5,557
28	2,881	3,594	5,762
29	2,984	3,726	5,968
30	3,087	3,859	6,174
31	3,190	3,987	6,380
32	3,293	4,116	6,586
33	3,396	4,245	6,791
34	3,499	4,373	6,997
35	3,601	4,502	7,203
36	3,704	4,630	7,409
37	3,807	4,759	7,615
38	3,910	4,888	7,820
39	4,013	5,016	8,026
40	4,116	5,145	8,232
41	4,227	5,293	8,453
42	4,337	5,442	8,674
43	4,448	5,590	8,896
44	4,559	5,739	9,117

45	4,669	5,887	9,338
46	4,780	6,035	9,560
47	4,890	6,184	9,781
48	5,001	6,332	10,002
49	5,112	6,481	10,223
50	5,222	6,629	10,445
51	5,327	6,762	10,654
52	5,431	6,894	10,862
53	5,536	7,027	11,071
54	5,640	7,159	11,280
55	5,745	7,292	11,489
56	5,849	7,425	11,698
57	5,953	7,557	11,907
58	6,058	7,690	12,116
59	6,162	7,822	12,325
60	6,267	7,955	12,534
61	6,371	8,102	12,742
62	6,476	8,250	12,951
63	6,580	8,397	13,160
64	6,685	8,545	13,369
65	6,789	8,692	13,578
66	6,893	8,840	13,787
67	6,998	8,987	13,996
68	7,102	9,134	14,205
69	7,207	9,282	14,414
70	7,311	9,429	14,623
71	7,429	9,564	14,857
72	7,546	9,699	15,092
73	7,663	9,833	15,327
74	7,781	9,968	15,562
75	7,898	10,103	15,797
76	8,016	10,238	16,031
77	8,133	10,372	16,266
78	8,250	10,507	16,501
79	8,368	10,642	16,736
80	8,485	10,776	16,971
81	8,607	10,931	17,213
82	8,728	11,086	17,456
83	8,849	11,241	17,699
84	8,971	11,395	17,941
85	9,092	11,550	18,184
86	9,213	11,705	18,427
87	9,335	11,860	18,669
88	9,456	12,014	18,912
89	9,577	12,169	19,155
90	9,699	12,324	19,397
91	9,806	12,461	19,613
92	9,914	12,598	19,828
93	10,022	12,735	20,044
94	10,130	12,871	20,259
95	10,238	13,008	20,475
96	10,345	13,145	20,691
97	10,453	13,282	20,906
98	10,561	13,419	21,122
99	10,669	13,556	21,337
100	10,776	13,693	21,553

HERZ - Standard diagram

HERZ - PICV

1 4406 34

DN 32

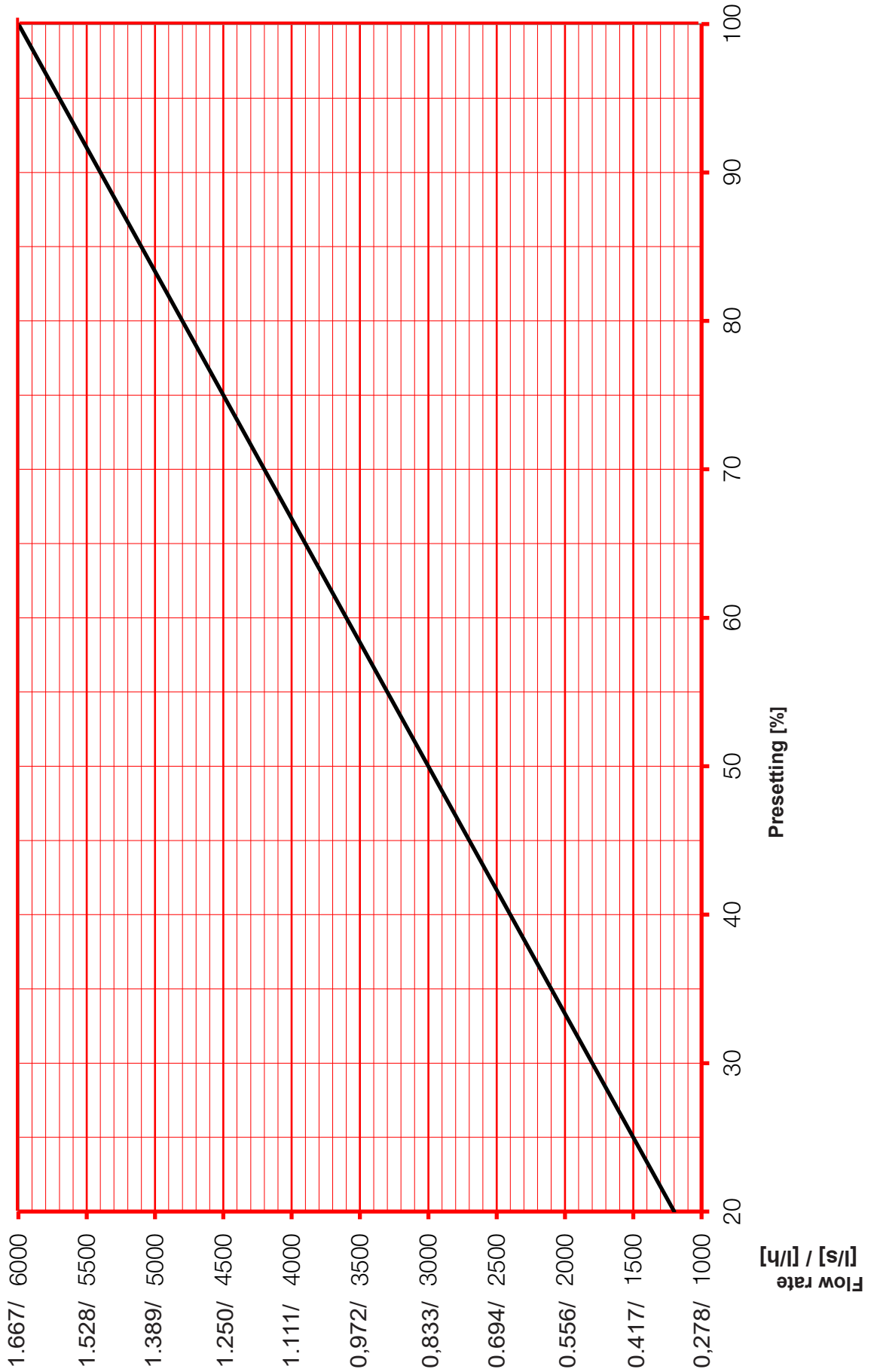

HERZ - Standard diagram

HERZ - PICV

1 4406 35



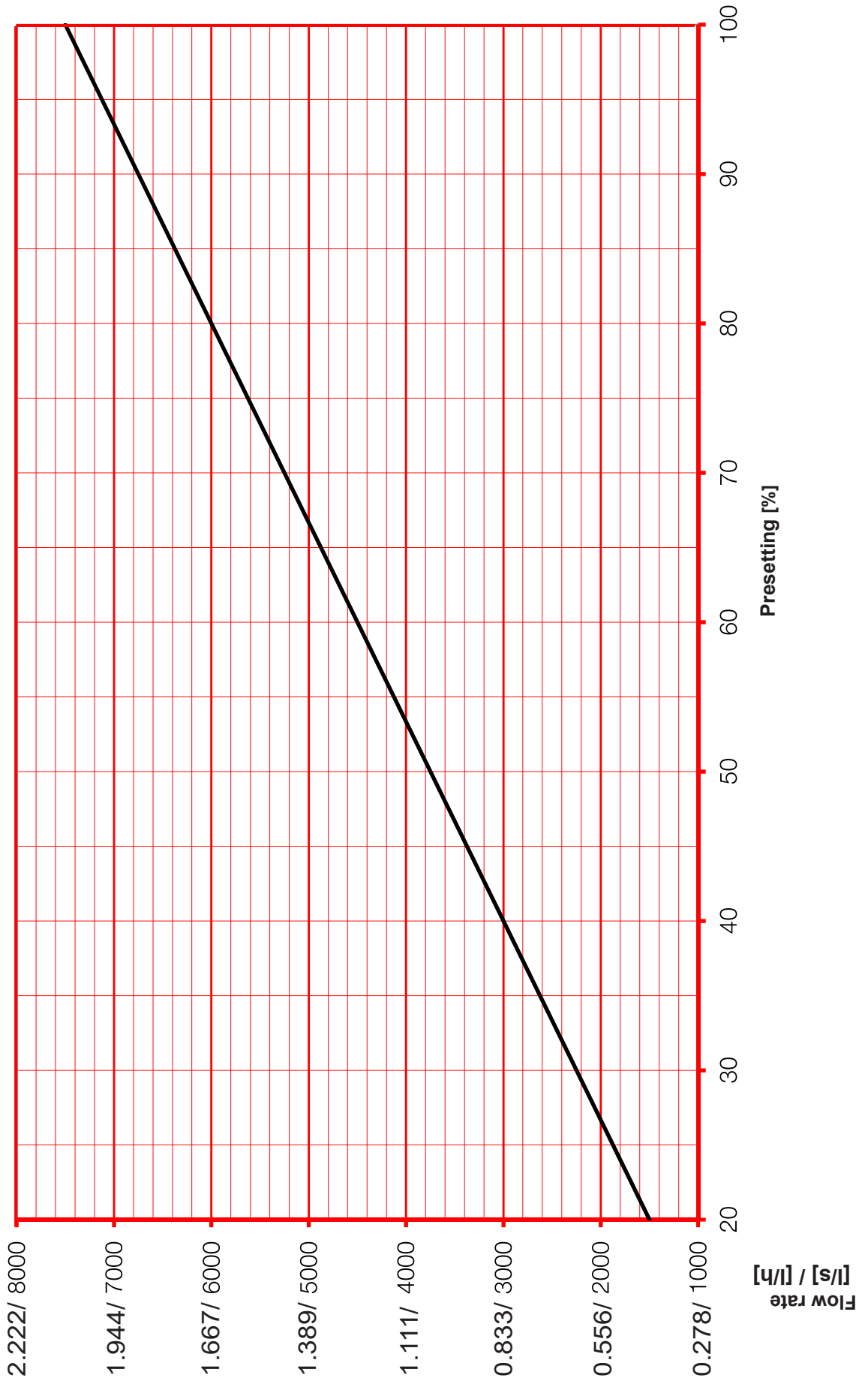

DN 40

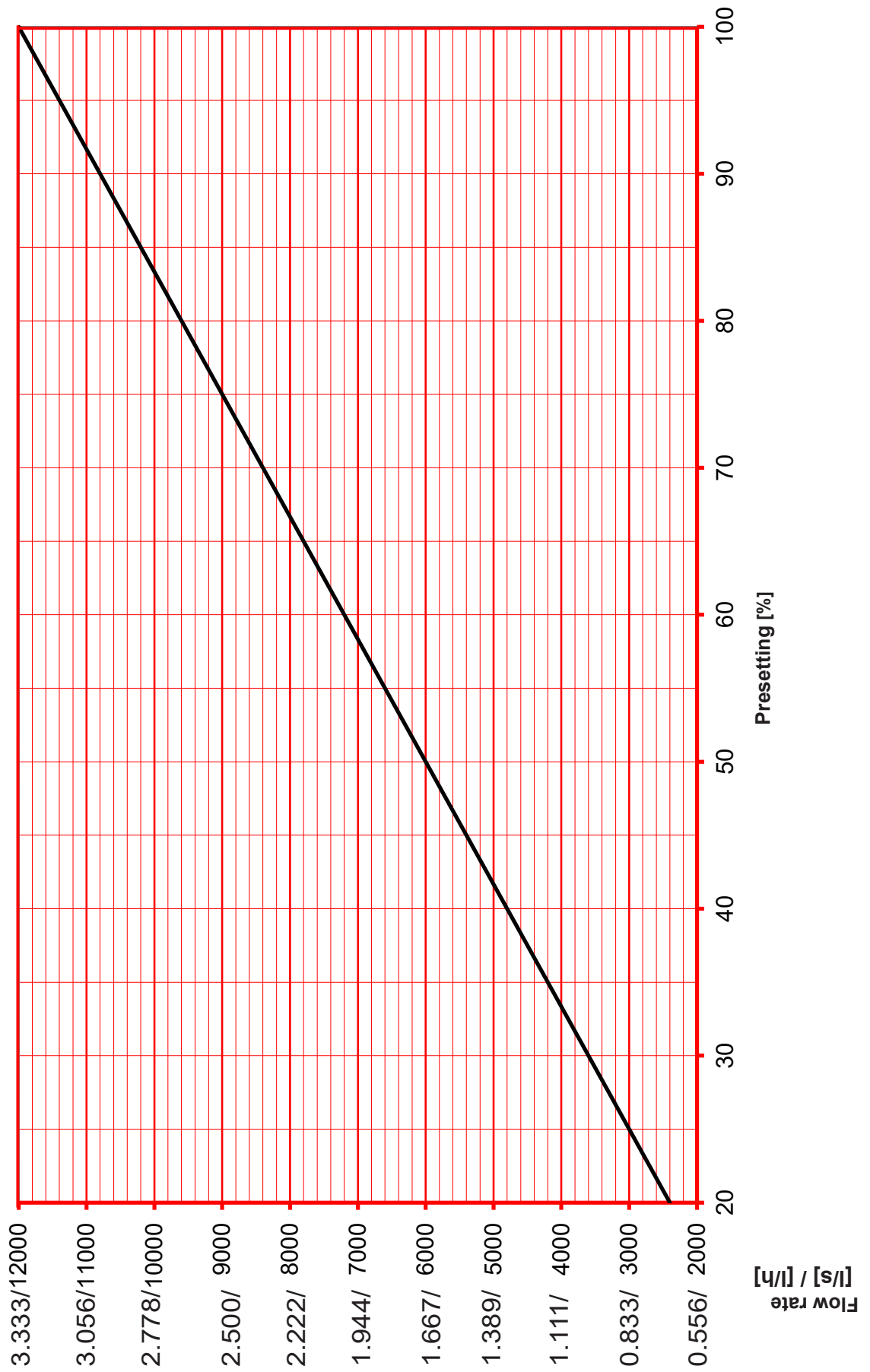







HERZ - Standard diagram	HERZ - PICV
1 4406 36	DN 50



☑ Accessories and spare parts

Article-number	Description	Picture
1 7708 40	<b>HERZ geared motor 3-point</b> Adapter M 28 x 1.5 colour red integrated, 24 V, stroke distance max. 8.5 mm, max. actuation force 200 N, 24 V / AC / DC	
1 7708 41	<b>HERZ geared motor 3-point</b> Adapter M 28 x 1.5 colour red integrated, 230 V, stroke distance max. 8.5 mm, max. actuation force 200 N, 230 V / AC	
1 7708 42	<b>HERZ geared motor DDC 0–10 V</b> Adapter M 28 x 1.5 colour red integrated, 24 V, stroke distance max. 8.5 mm, max. actuation force 200 N, 24 V / AC / DC, Steuersignal 0... 10 V / DC	
1 7708 46	<b>HERZ geared motor DDC 0–10 V</b> Adapter M 28 x 1.5 colour red integrated, 24 V, stroke distance max. 8.5 mm, max. actuation force 200 N. With valve port detection and feedback channel, 24 V / AC / DC, Steuersignal 0... 10 V / DC	
1 7708 47	<b>HERZ geared motor DDC 0–10 V failsafe</b> Adapter M 28 x 1.5 colour red integrated, 24 V AC/DC, stroke distance max. 8.5 mm, max. actuation force 200 N. With failsafe function, closes in case of power failure. With valve stroke detection and feedback channel.	
1 4406 34	<b>HERZ pressure-independent control valve,</b> Compact shape, body of dezincification-resistant brass, male thread connection with flat sealing, threaded connection for drive M 28 x 1.5, model with 3 test points, DN32, suitable for D H409 06, D H409 07, D H409 08, D H409 09, D H410 06, D H410 07, D H410 08, D H410 09..	
1 4406 35	<b>HERZ pressure-independent control valve,</b> Compact shape, body of dezincification-resistant brass, male thread connection with flat sealing, threaded connection for drive M 28 x 1.5, model with 3 test points, DN40, suitable for D H409 10, D H409 11, D H409 12, D H410 10, D H410 11, D H410 12.	
1 4406 36	<b>HERZ pressure-independent control valve,</b> Compact shape, body of dezincification-resistant brass, male thread connection with flat sealing, threaded connection for drive M 28 x 1.5, model with 3 test points DN50, suitable for D H409 13, D H410 13.	
1 2608 03	<b>Pressure relief safety valve DN25, PN3,</b> suitable for D H409 06, D H409 07, D H409 08, D H409 09, D H410 06, D H410 07, D H410 08, D H410 09.	
1 2610 04	<b>Pressure relief safety valve DN32, PN3,</b> suitable for D H409 10, D H409 11, D H409 12, D H409 13, D H410 10, D H410 11, D H410 12, D H410 13	
1 2662 05	<b>HERZ strainer, mesh size 0,5 mm</b> body made of dezincification-resistant brass, socket x socket, strainer insert 1 6385 95 made of stainless steel. Suitable for D H409 06, D H409 07, D H409 08, D H410 06, D H410 07, D H410 08.	
1 2662 06	<b>HERZ strainer, mesh size 0,5 mm</b> body made of dezincification-resistant brass, socket x socket, strainer insert 1 6385 96 made of stainless steel. Suitable for D H409 09, D H409 10, D H409 11, D H409 12, D H409 13, D H410 09, D H410 10, D H410 11, D H410 12, D H410 13.	

☑ Accessories

Article-number	Description	Picture
D H499 30	<p><b>CONTROL UNIT "SCHNEID"</b></p> <ul style="list-style-type: none"> <li>- for controlling the district heating substation;</li> <li>- prepared for controlling a mixed heating circuit (3-point actuator, 230 V; sensor and actuator must be ordered separately);</li> <li>- prepared for controlling an direct heating circuit (230 V; sensor must be ordered separately);</li> <li>- expandable with the HK08 STANDARD heating circuit module or the MR12 AIN add-on board.</li> </ul> <p>Unit includes:            MR12 control panel; MR12 basic terminal board AKP with 5 plug-in modules; HK08 STANDARD heating circuit module; CM12 communication base module; CM-MBM plug-in card module; CM-422 plug-in card module; MIDI housing with door (32.5 × 21 × 12 cm); outdoor sensor with plastic housing (D H499 11); 3 × immersion sensors, 2 m long (D H499 10); 6 × PG cable glands pre-installed in the housing (4 on the bottom, 2 on the right); fully wired.</p>	
	<p><b>Accessories:</b></p>	
D H499 31	<p><b>Heating circuit module HK08 STANDARD 40x100x24 mm, incl. 10-pin ribbon cable, standard length 800 mm</b></p> <p>Module for an additional 3-point mixer heating circuit (230 V), protection class: IP20, operating voltage: 12 V DC, max. rated current per output: 2 A continuous current // max. 15 A inrush current</p>	
D H499 32	<p><b>MR12 AIN add-on board without plug-in modules, 55x100x24 mm</b></p> <p>8 analog inputs (AI): 0–10 V or 4 analog outputs (AO): 0–10 V and 3 digital outputs (DO): 12 V, protection class: IP00, operating voltage: 12 V DC</p>	
D H499 10	<p><b>PT1000 immersion sensor</b></p> <p>Sleeve diameter 6 mm, nominal sensor length 6 x 50 mm, cable length 2 m; Protection class: IP65; Measuring range -50...+200 °C</p>	
D H499 11	<p><b>PT1000 113 outdoor sensor, 3 x 66 x 50 mm</b></p> <p>IEC/EN protection rating: IP65; IEC/EN protection class: III safety extra-low voltage (SELV); measuring range: -35...50 °C; max. ambient humidity 95% r.h., non-condensing; cable entry: cable gland with strain relief Ø 6...8 mm; electrical connection: plug-in spring-loaded terminal, max. 2.5 mm<sup>2</sup></p>	
D H499 12	<p><b>PT1000 contact sensor</b></p> <p>Cable length: 2 m, protection class: IP54; measuring range: -30...+180°C</p>	

☑ Dimensions, mm

D H409 06 (60 plates)

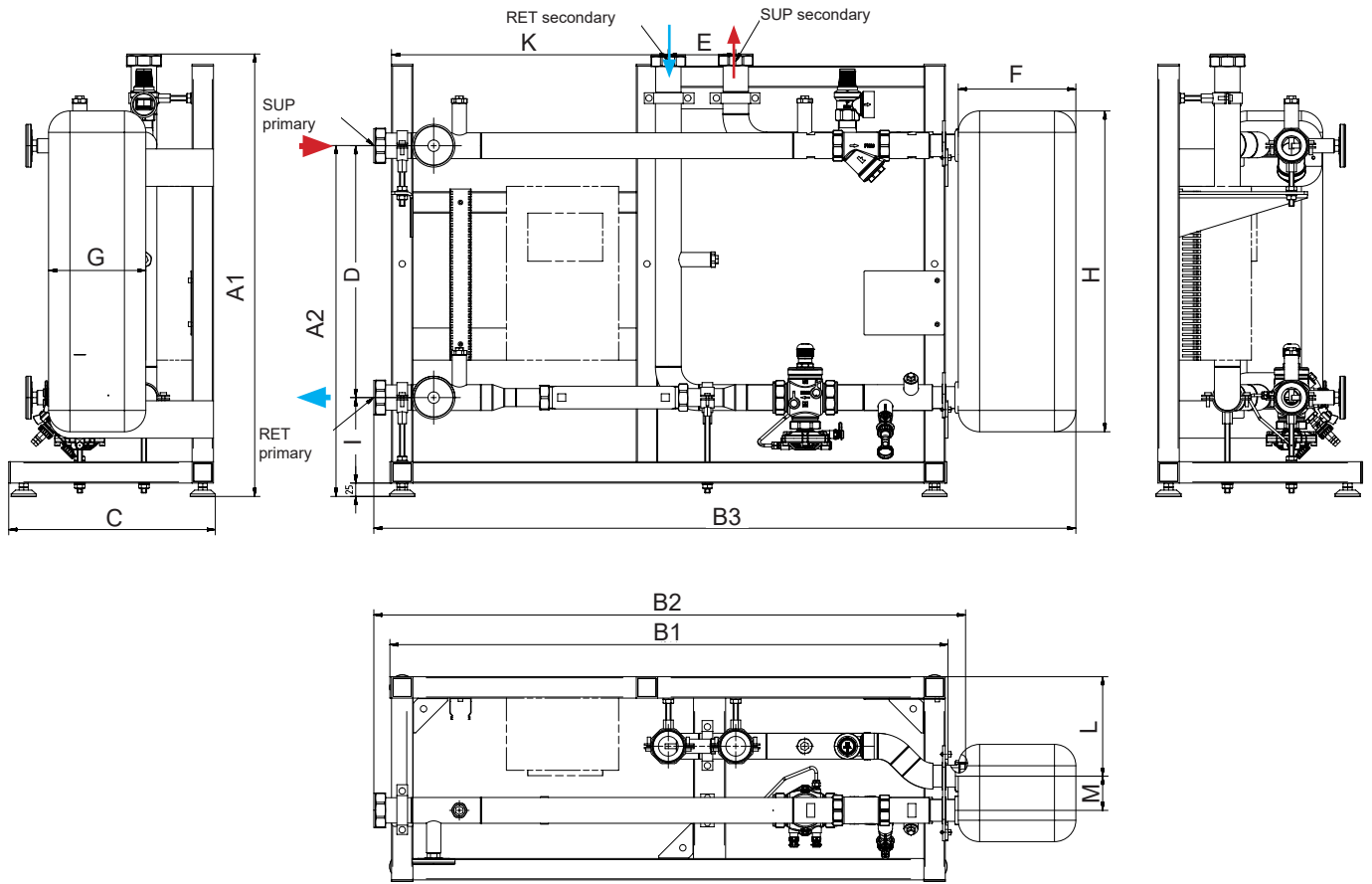

A1	A2	B1	B2	B3	C	D	E	F	G	H	I	K	L	M	Connection SUP / RET, primary	Connection SUP / RET, secondary
825	656	1004	1106	1278	~ 387	471	125	220	182	600	160	508	186	64	2"	2"

Allocation of heat meters

Spacer for the heat meters	Overall length	Connection size
	260	G1 1/4"

☑ Dimensions, mm

D H410 06 (60 plates)  
insulated

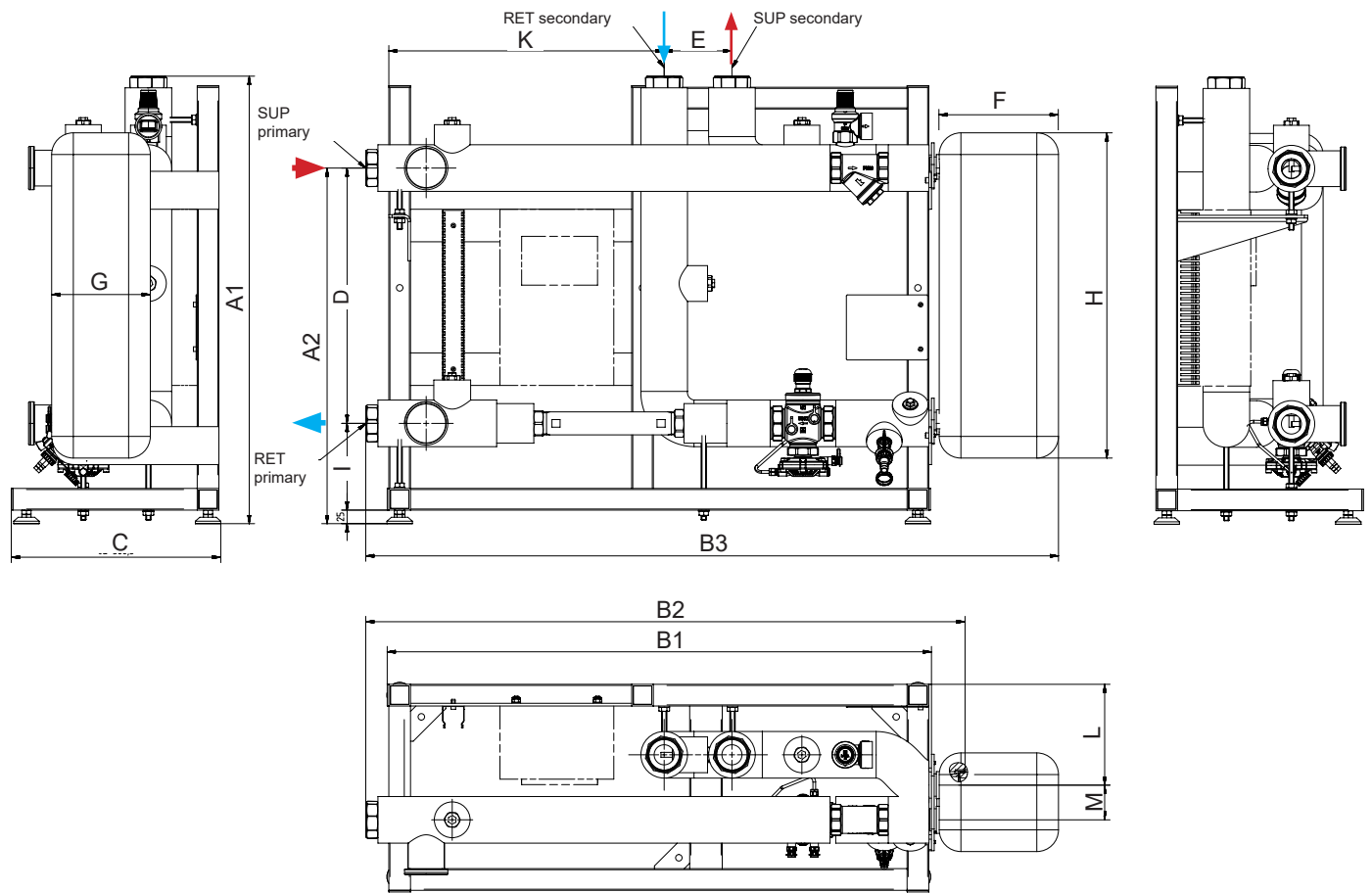

A1	A2	B1	B2	B3	C	D	E	F	G	H	I	K	L	M	Connection SUP / RET, primary	Connection SUP / RET, secondary
825	656	1004	1106	~1278	~ 387	471	125	220	182	600	160	508	186	64	2"	2"

Allocation of heat meters

Spacer for the heat meters	Overall length	Connection size
	260	G1 1/4"

☑ Dimensions, mm

D H408 07 (70 plates)

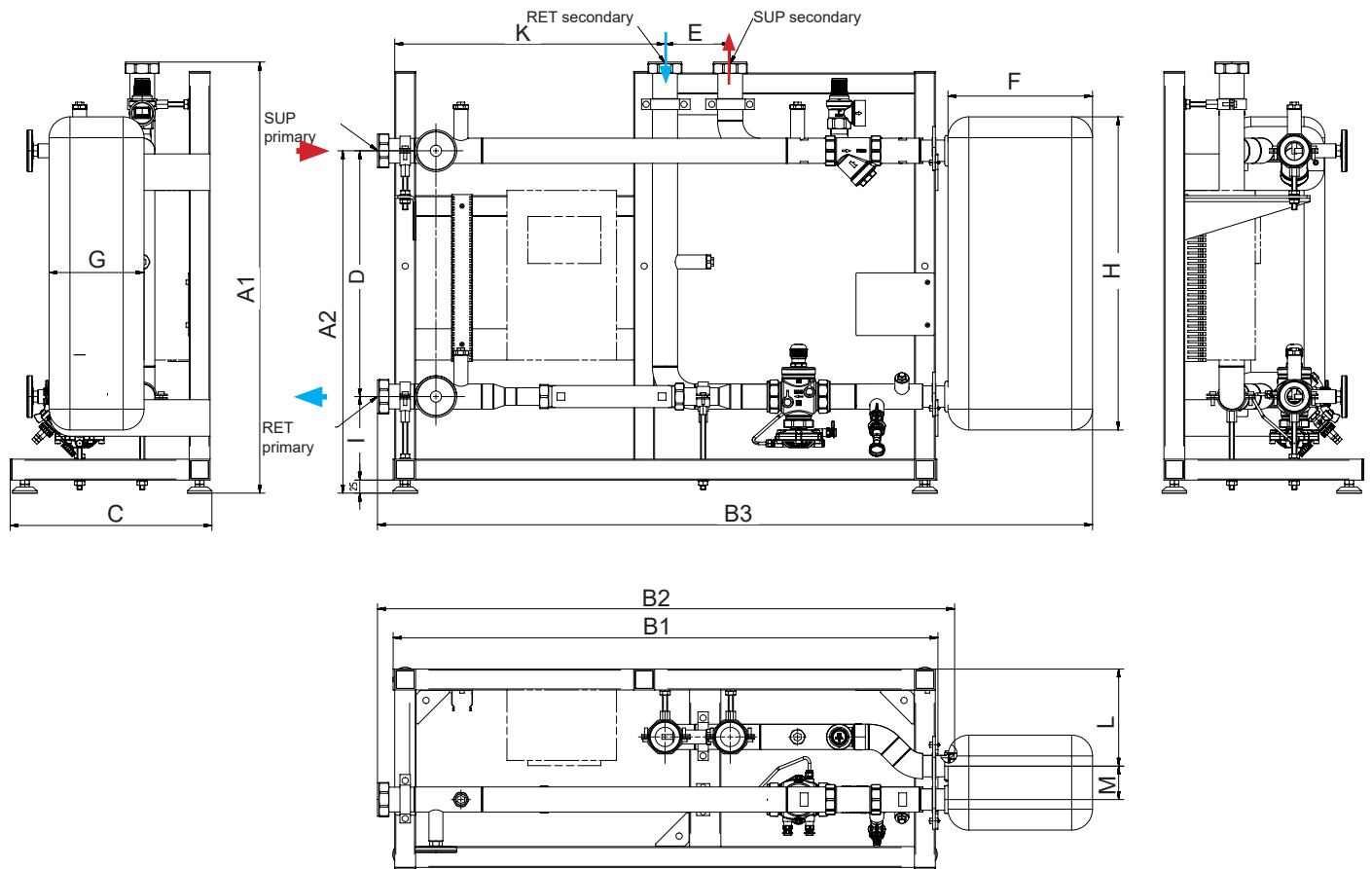

A1	A2	B1	B2	B3	C	D	E	F	G	H	I	K	L	M	Connection SUP/ RET, primary	Connection SUP/ RET, secondary
825	656	1004	1106	~1335	~387	471	125	277	182	600	160	508	186	64	2"	2"

Allocation of heat meters

Spacer for the heat meters	Overall length	Connection size
	260	G1 1/4"

☑ Dimensions, mm

D H410 07 (70 plates)  
insulated

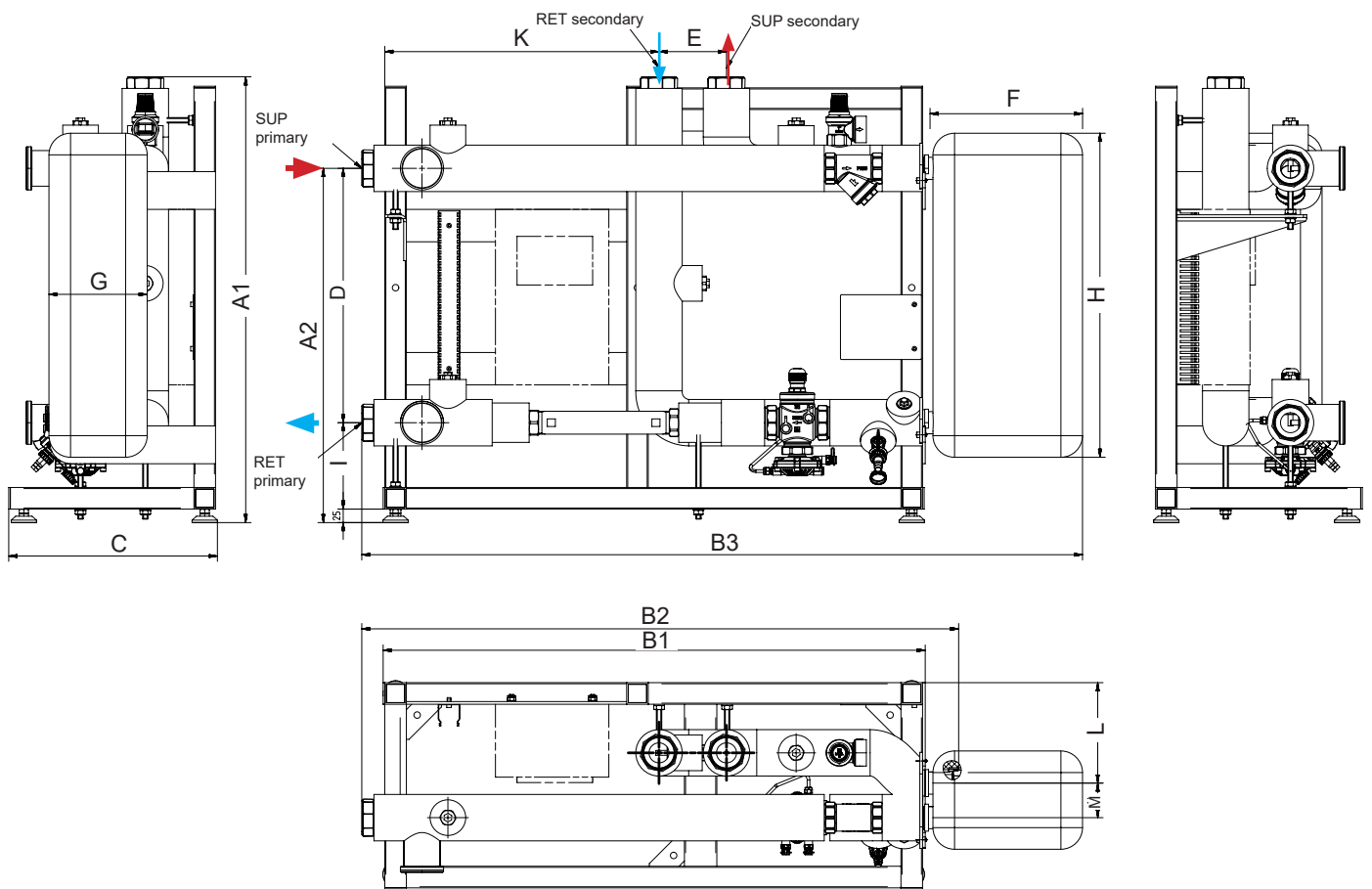

A1	A2	B1	B2	B3	C	D	E	F	G	H	I	K	L	M	Connection SUP/ RET, primary	Connection SUP/ RET, secondary
825	656	1004	1106	~1335	~ 387	471	125	277	182	600	160	508	186	64	2"	2"

Allocation of heat meters

Spacer for the heat meters	Overall length	Connection size
	260	G1 1/4"

☑ Dimensions, mm

D H408 08 (80 plates)

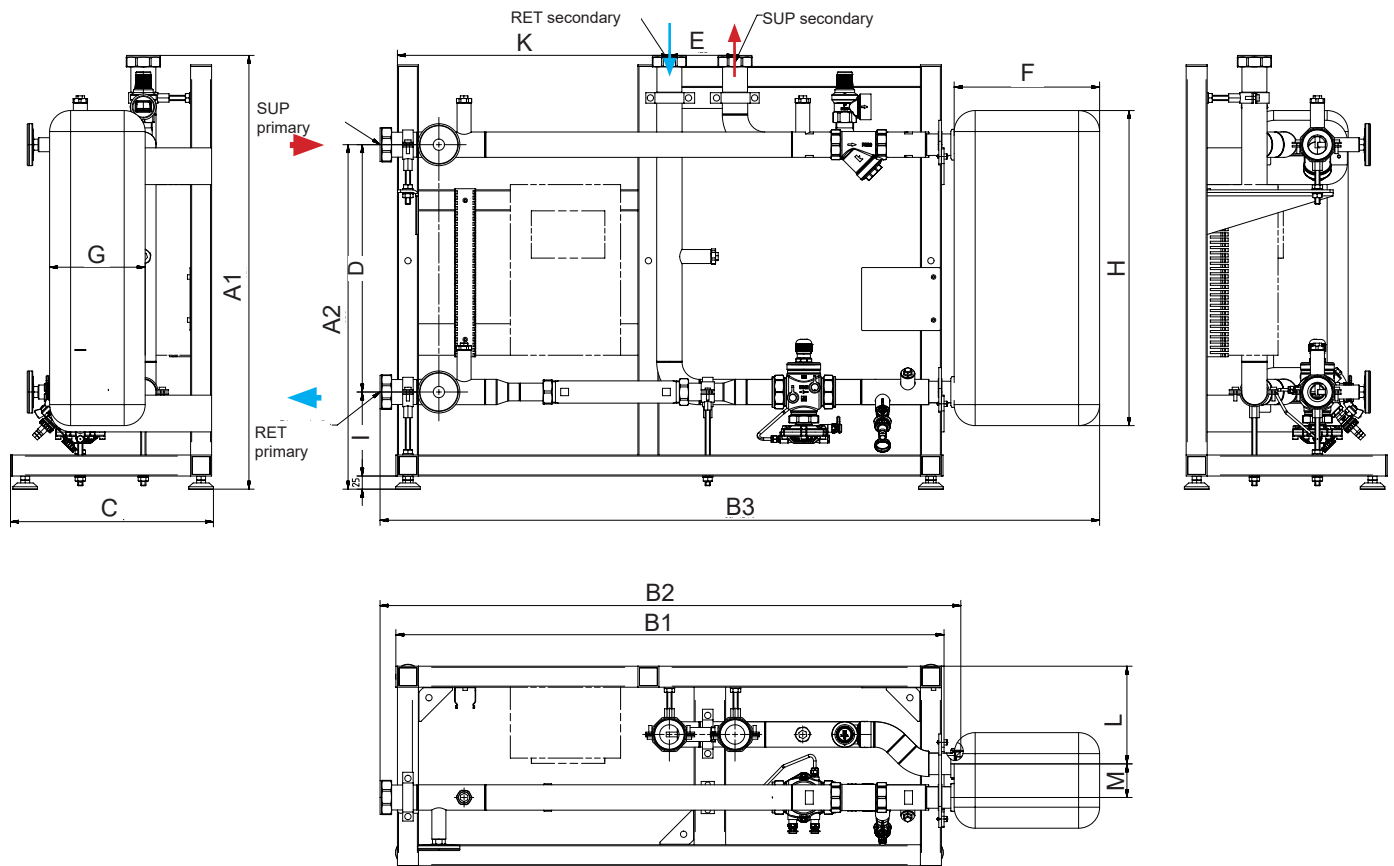

A1	A2	B1	B2	B3	C	D	E	F	G	H	I	K	L	M	Connection SUP / RET, primary	Connection SUP / RET, secondary
825	656	1004	1106	~1335	~ 387	471	125	277	182	600	160	508	186	64	2"	2"

Allocation of heat meters

Spacer for the heat meters	Overall length	Connection size
	260	G1 1/4"



☑ Dimensions, mm

D H408 09 (90 plates)

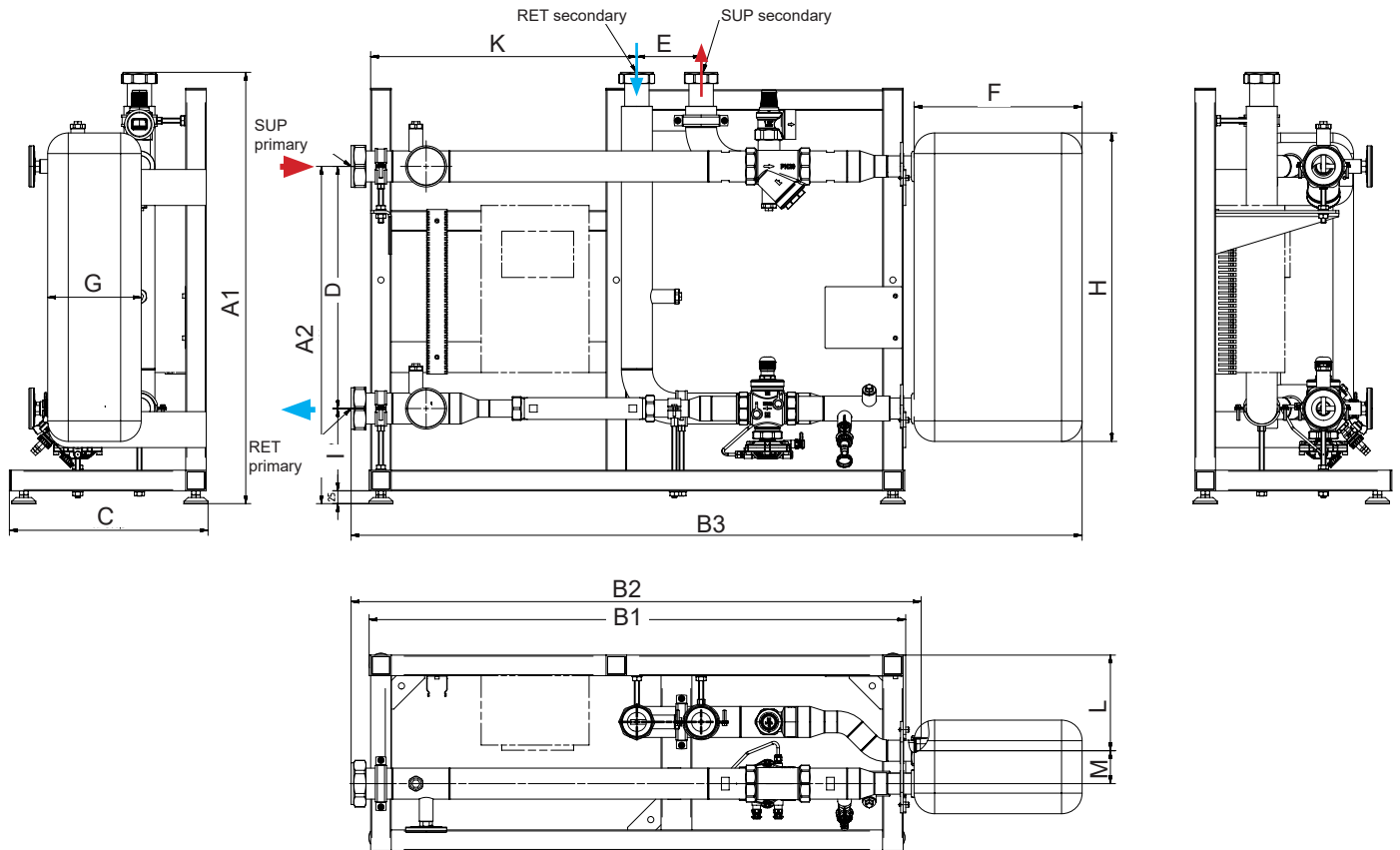

A1	A2	B1	B2	B3	C	D	E	F	G	H	I	K	L	M	Connection SUP / RET, primary	Connection SUP / RET, secondary
838	656	1004	1109	~1387	~387	471	125	327	182	600	160	508	186	64	2 1/2"	2"

Allocation of heat meters

Spacer for the heat meters	Overall length	Connection size
	260	G1 1/4"

☑ Dimensions, mm

D H410 09 (90 plates)  
insulated

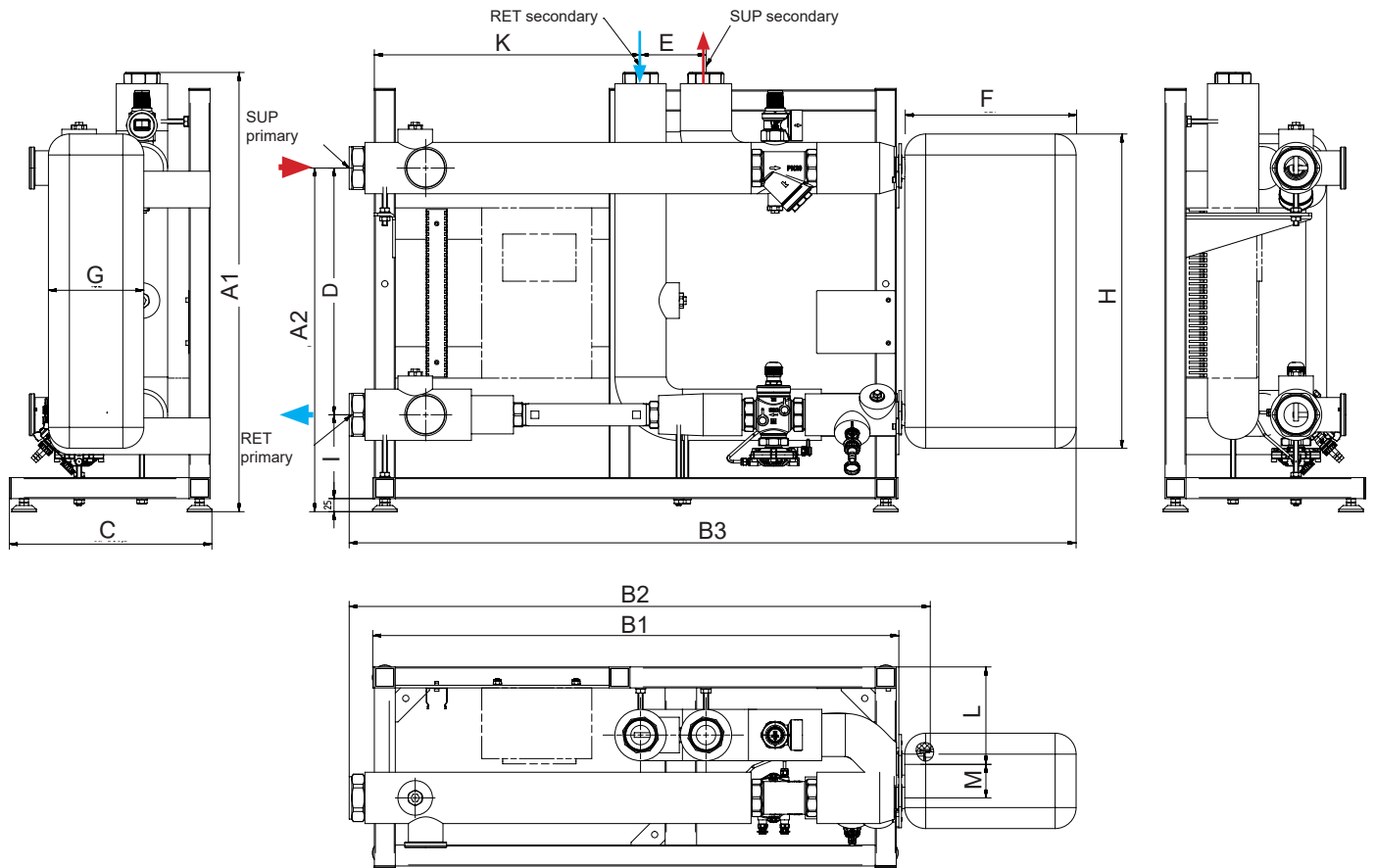

A1	A2	B1	B2	B3	C	D	E	F	G	H	I	K	L	M	Connection SUP / RET, primary	Connection SUP / RET, secondary
838	656	1004	1109	~1387	~387	471	125	327	182	600	160	508	186	64	2 1/2"	2"

Allocation of heat meters

Spacer for the heat meters	Overall length	Connection size
	260	G1 1/4"

☑ Dimensions, mm

D H408 10 (100 plates)

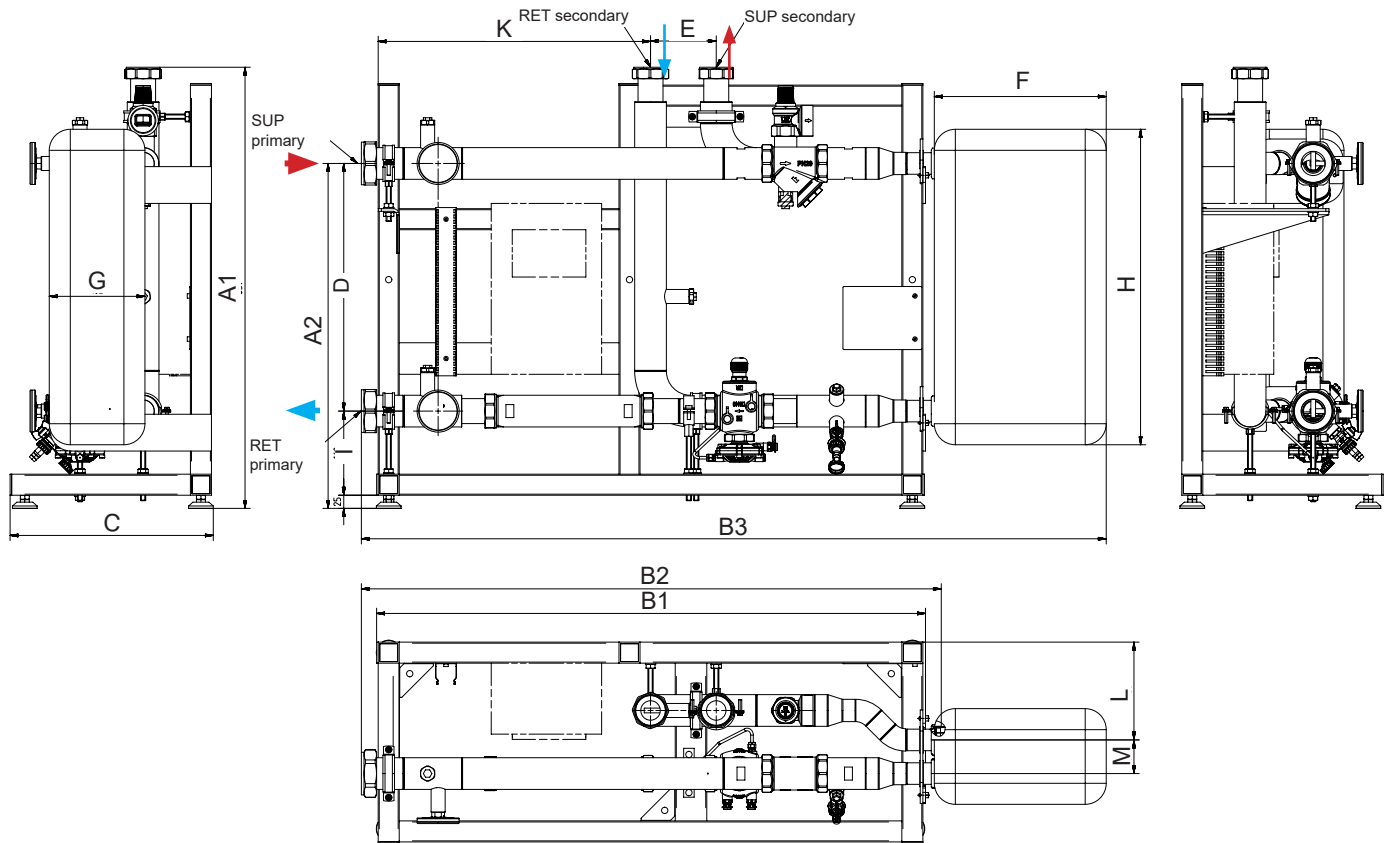

A1	A2	B1	B2	B3	C	D	E	F	G	H	I	K	L	M	Connection SUP / RET, primary	Connection SUP / RET, secondary
838	656	1004	1103	~1381	~387	471	125	327	182	600	160	508	186	64	2 1/2"	2"

Allocation of heat meters

Spacer for the heat meters	Overall length	Connection size
	300	G2"

☑ Dimensions, mm

D H410 10 (100 plates)

insulated

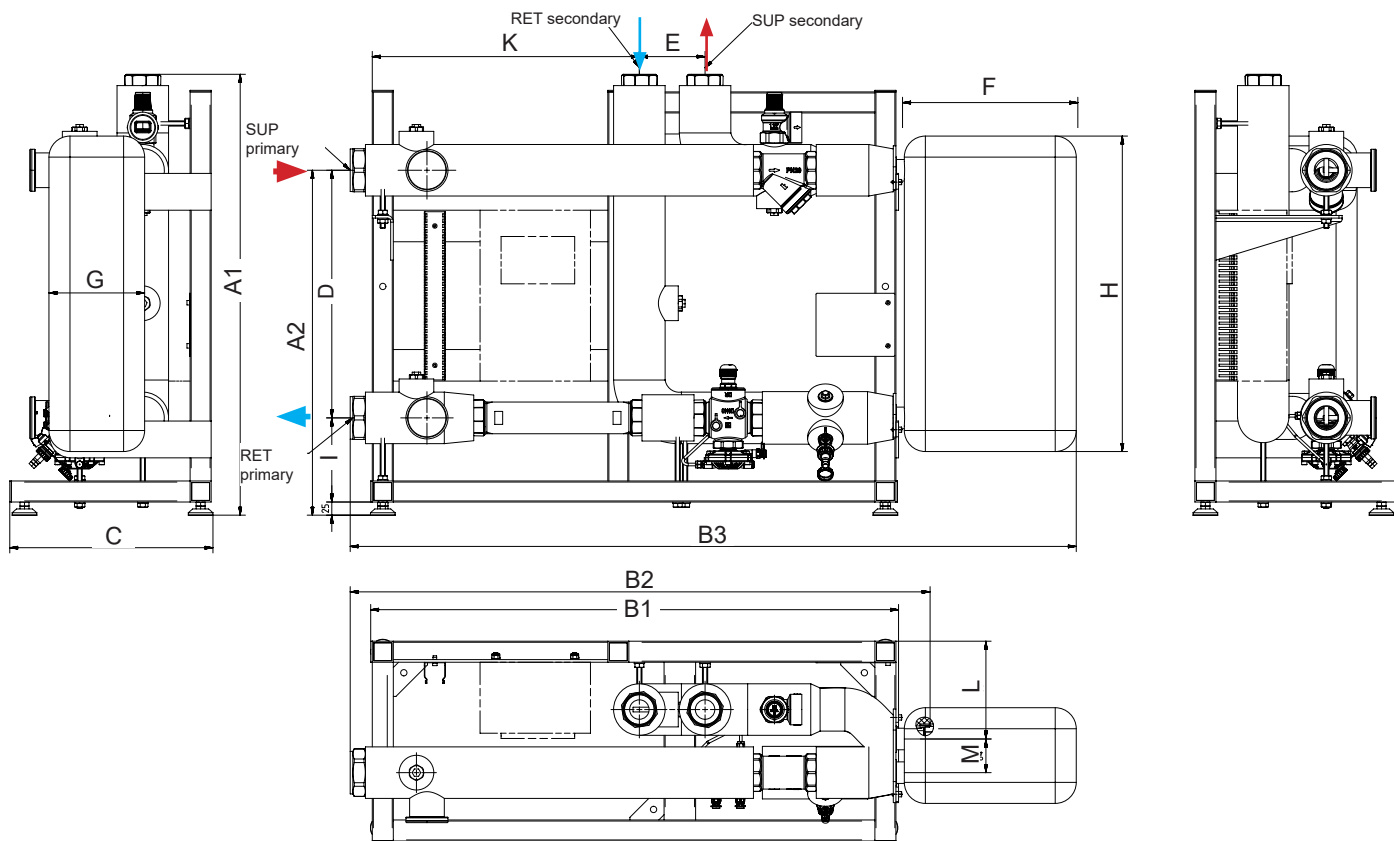

A1	A2	B1	B2	B3	C	D	E	F	G	H	I	K	L	M	Connection SUP / RET, primary	Connection SUP / RET, secondary
838	656	1004	1103	~1381	~387	471	125	327	182	600	160	508	186	64	2 1/2"	2"

Allocation of heat meters

Spacer for the heat meters	Overall length	Connection size
	300	G2"

☑ Dimensions, mm

D H408 11 (120 plates)

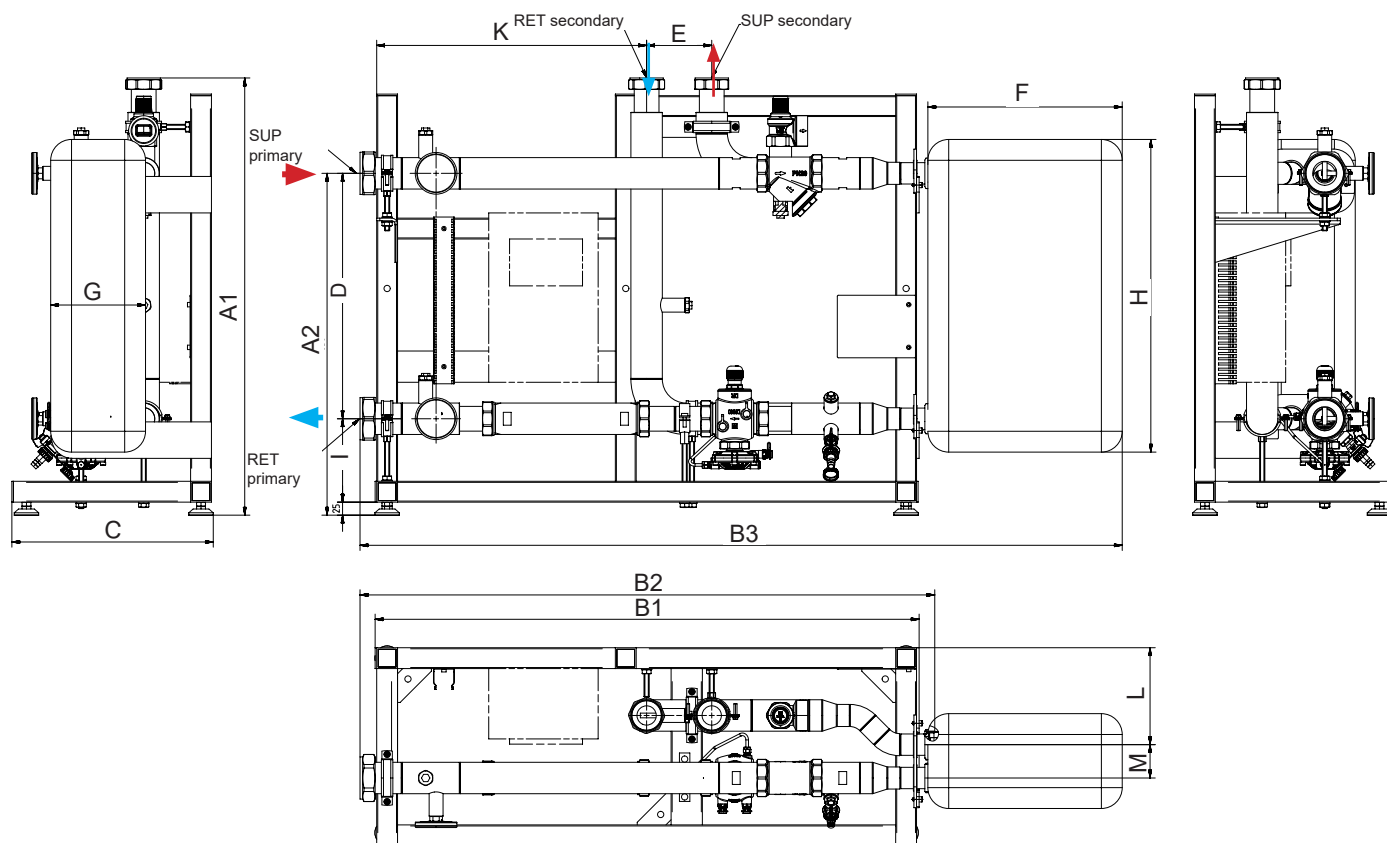

A1	A2	B1	B2	B3	C	D	E	F	G	H	I	K	L	M	Connection SUP / RET, primary	Connection SUP / RET, secondary
838	656	1004	1103	~1428	~387	471	125	373	182	600	160	508	186	64	2 1/2"	2"

Allocation of heat meters

Spacer for the heat meters	Overall length	Connection size
	300	G2"

☑ Dimensions, mm

D H410 11 (120 plates)  
insulated

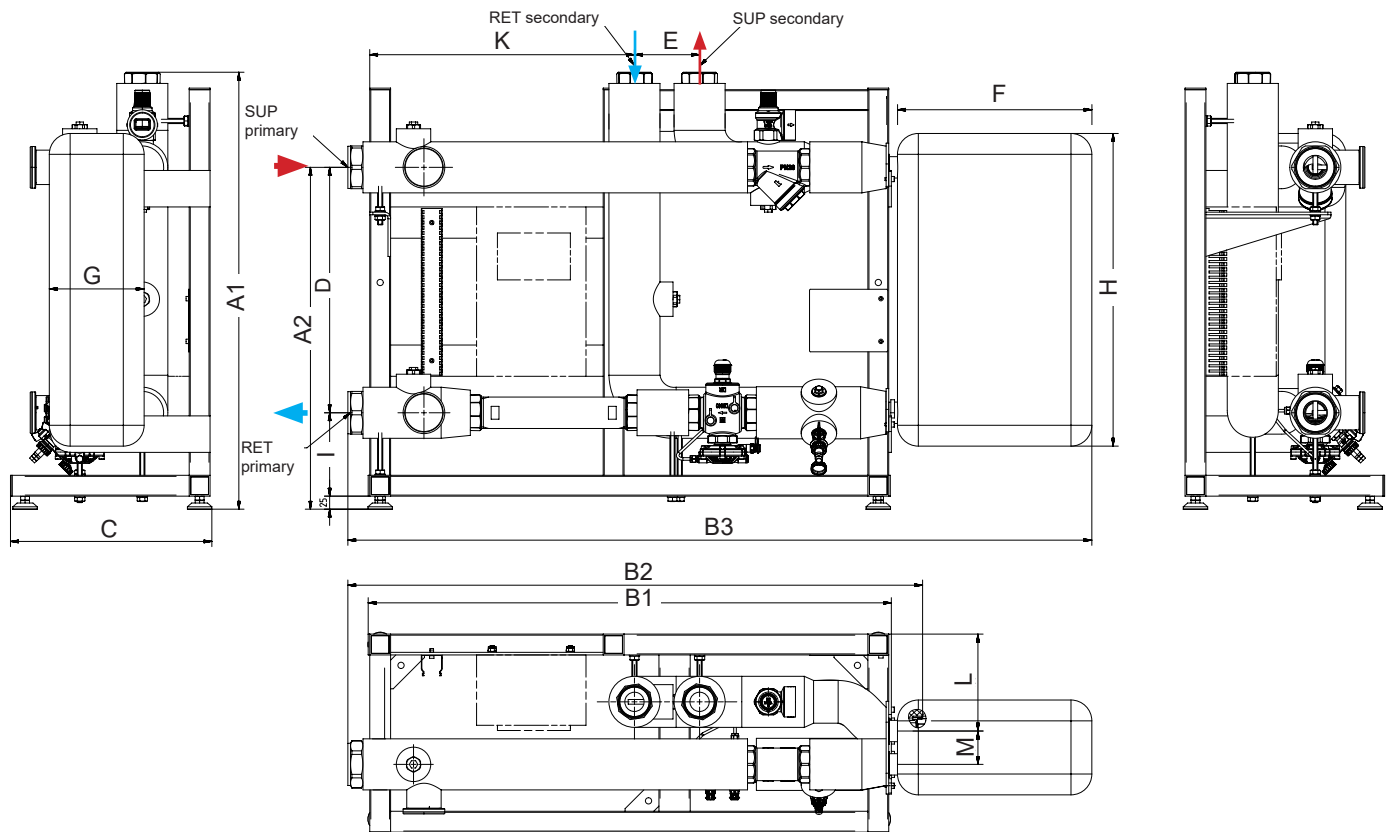

A1	A2	B1	B2	B3	C	D	E	F	G	H	I	K	L	M	Connection SUP / RET, primary	Connection SUP / RET, secondary
838	656	1004	1103	~1428	~387	471	125	373	182	600	160	508	186	64	2 1/2"	2"

Allocation of heat meters

Spacer for the heat meters	Overall length	Connection size
	300	G2"

☑ Dimensions, mm

D H408 12 (140 plates)

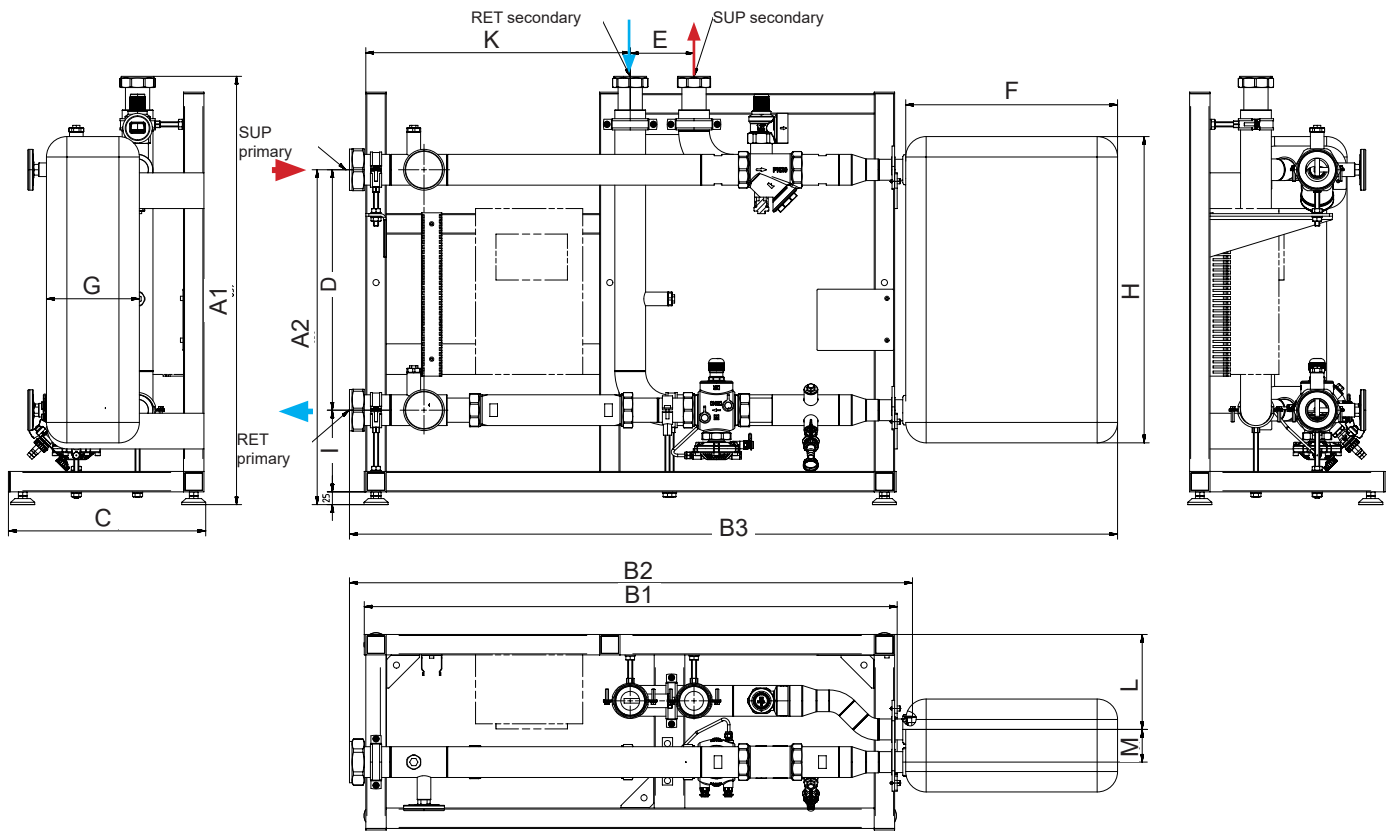

A1	A2	B1	B2	B3	C	D	E	F	G	H	I	K	L	M	Connection SUP / RET, primary	Connection SUP / RET, secondary
838	656	1004	1103	~1470	~ 387	471	125	415	182	600	160	508	186	64	2 1/2"	2"

Allocation of heat meters

Spacer for the heat meters	Overall length	Connection size
	300	G2"

☑ Dimensions, mm

D H410 12 (140 plates)  
insulated

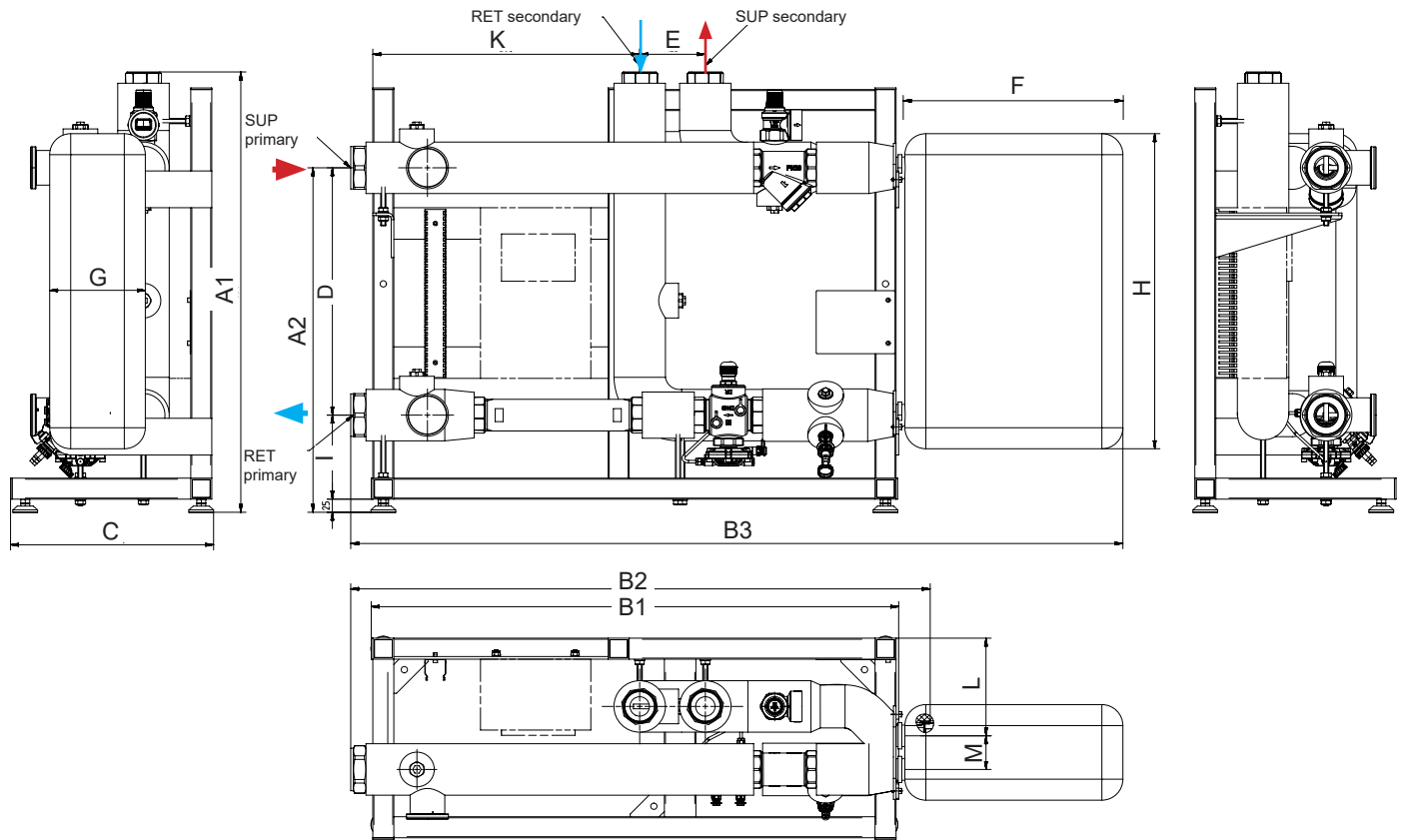

A1	A2	B1	B2	B3	C	D	E	F	G	H	I	K	L	M	Connection SUP / RET, primary	Connection SUP / RET, secondary
838	656	1004	1103	~1470	~387	471	125	415	182	600	160	508	186	64	2 1/2"	2"

Allocation of heat meters

Spacer for the heat meters	Overall length	Connection size
	300	G2"

☑ Dimensions, mm

D H408 13 (160 plates)

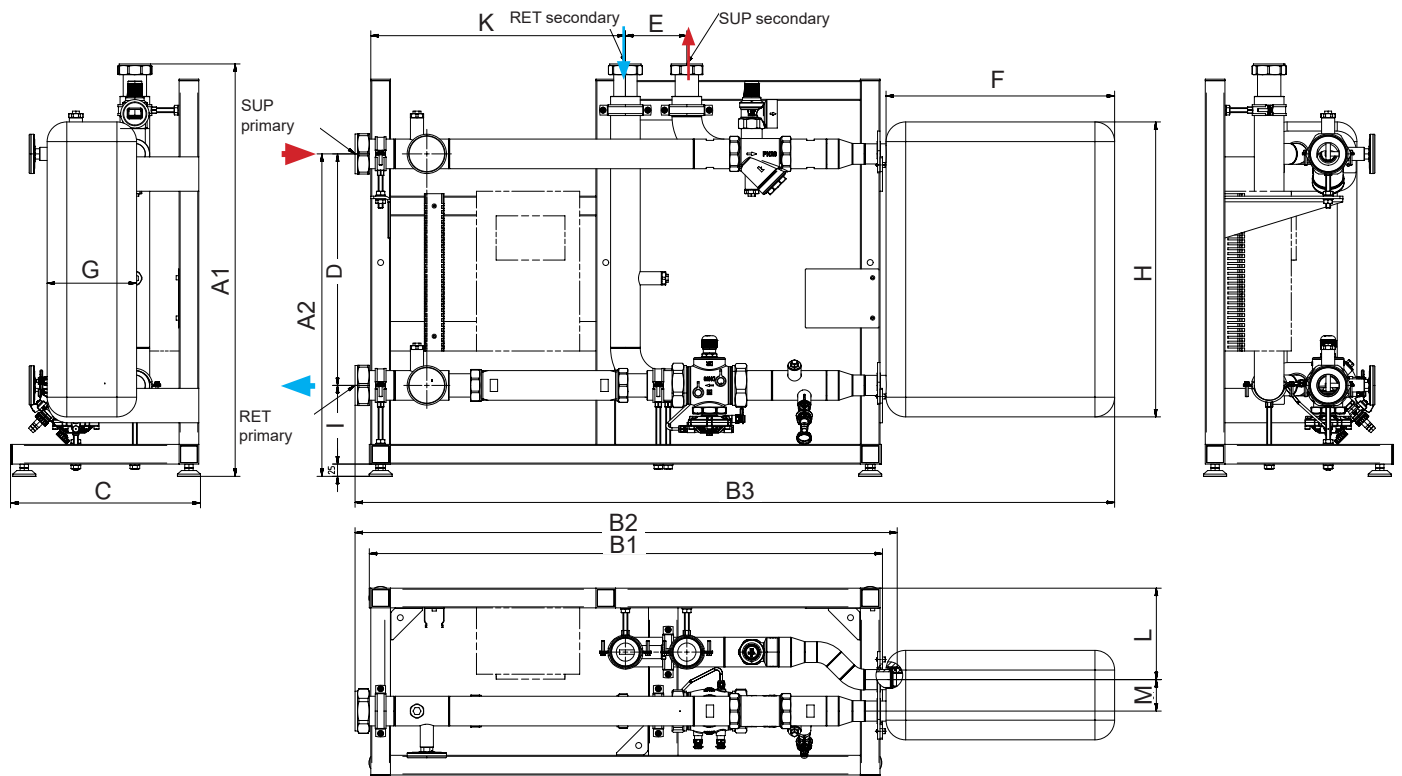

A1	A2	B1	B2	B3*	C	D	E	F*	G*	H*	I	K	L	M	Connection SUP / RET, primary	Connection SUP / RET, secondary
838	656	1004	1103	~1517	~387	471	125	465	182	600	160	508	186	64	2 1/2"	2"

\* depending on the insulation

Allocation of heat meters

Spacer for the heat meters	Overall length	Connection size
	300	G2"

☑ Dimensions, mm

D H410 13 (160 plates)  
insulated

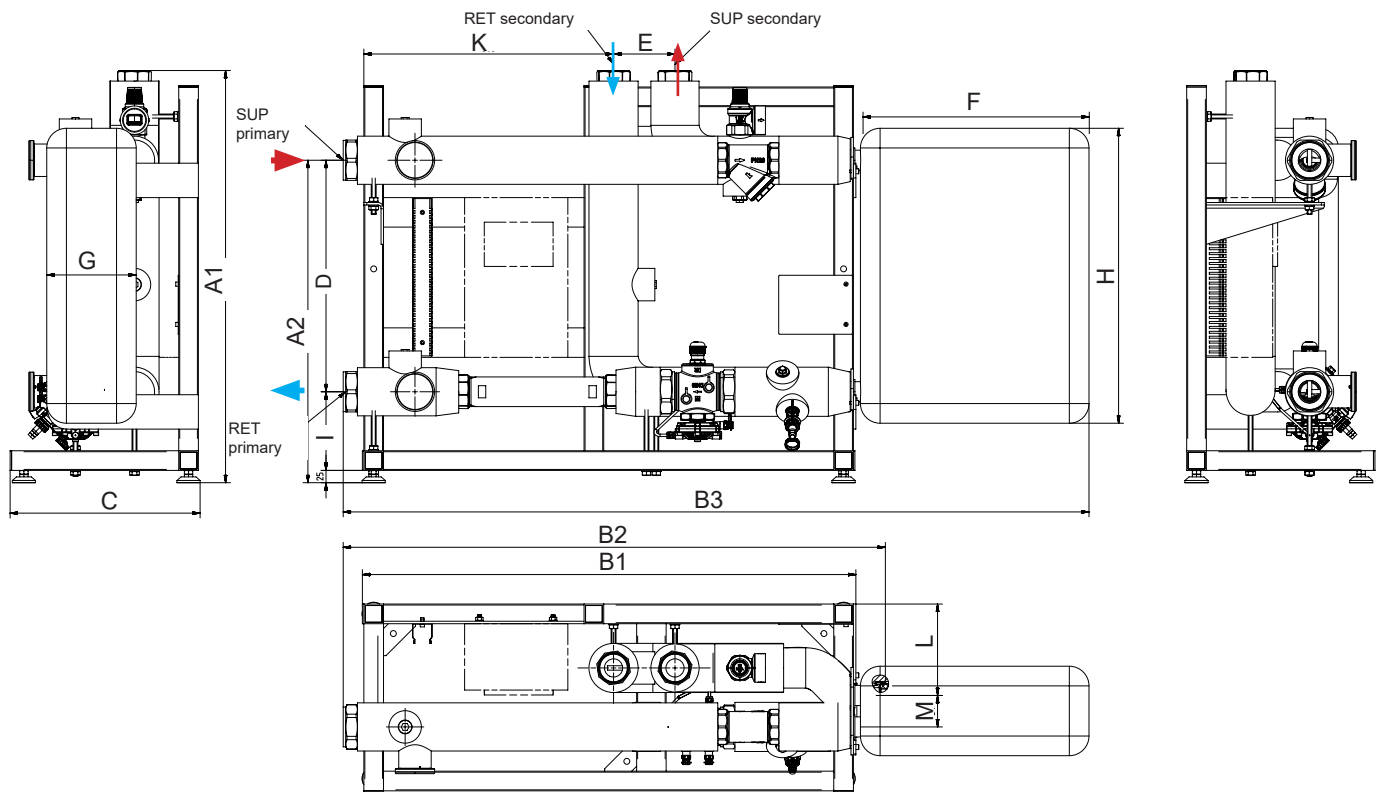

A1	A2	B1	B2	B3*	C	D	E	F*	G*	H*	I	K	L	M	Connection SUP / RET, primary	Connection SUP / RET, secondary
838	656	1004	1103	~1517	~ 387	471	125	465	182	600	160	508	186	64	2 1/2"	2"

\*depending on the insulation

Allocation of heat meters

Spacer for the heat meters	Overall length	Connection size
	300	G2"