

Water meter set

after ÖNORM B 2531

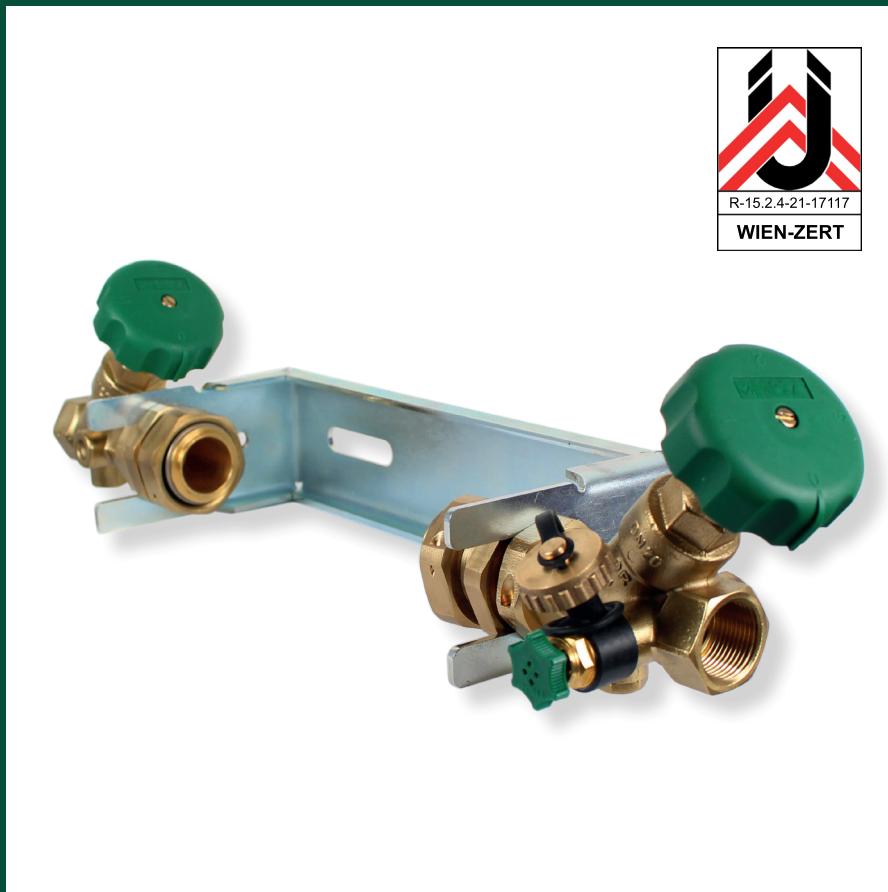

- ☑ Stable structure with open galvanized sheet steel frame
- ☑ ÜA installation sign for legally compliant installation in drinking water installations in Austria
- ☑ Shut-off valve in front of the water meter
- ☑ Backflow preventer, shut-off and draining after the water meter
- ☑ Length compensation for simple water meter installation
- ☑ Both union nuts can be sealed
- ☑ Non-rising stems with dual O-ring seals
- ☑ Austrian product

WATER METER SET

The HERZ water meter set combines the functionalities of isolating the water meter, sealability of the union nuts to the water meter, simple and stress-free installation of the water meter by means of length compensation as well as backflow prevention, shut-off and draining after the the water meter. This corresponds to the specifications of the standards EN 806, DIN 1988 and ÖNORM B 2531. Fastening material is included.

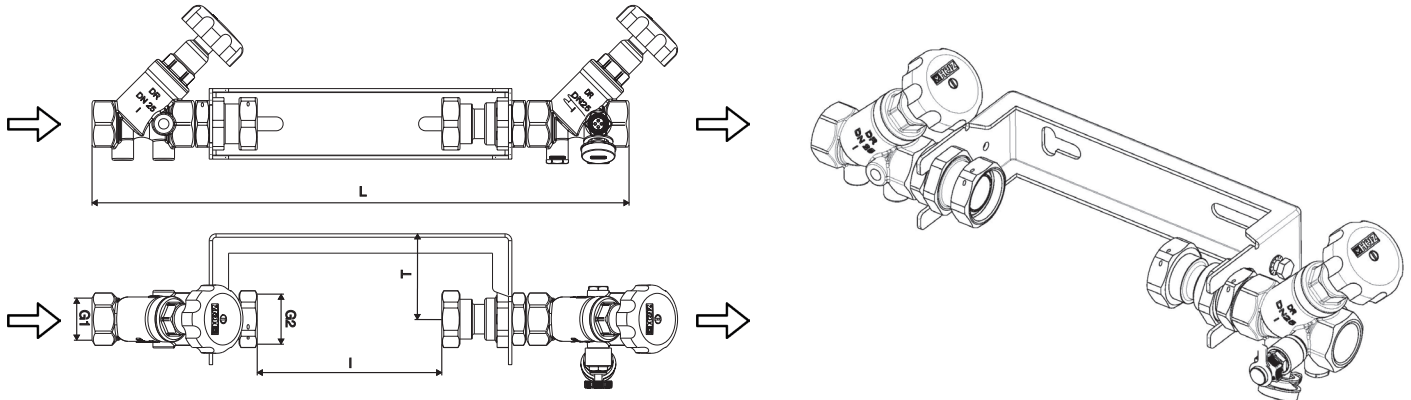

Order number	DN	G1	G2	l [mm]	T [mm]	L [mm]	Min. l/s
2 4126 62	20	3/4"	1 1/4"	175 +9 -9	75 - 95	440	1,00
2 4126 63	25	1"	1 1/4"	175 +9 -9	75 - 95	470	1,75
2 4126 64	32	1 1/4"	1 1/4"	175 +9 -9	75 - 95	509	3,00
2 4126 65	40	1 1/2"	2"	300 +18,5 -15	120 + 20	666	4,00
2 4126 66	50	2"	2"	300 +8,5 -18	119 + 20	733	6,76



Materials

Housing: Dezincification-resistant brass suitable for drinking water hygiene according to the current UBA list and the 4MS list
 Spring: stainless steel
 Bracket: galvanized sheet steel incl. earthing screw

Technical data

Max. working pressure: 16 bar
 Min. operating temperature: 2 °C
 Max. operating temperature: 85 °C

Installation example

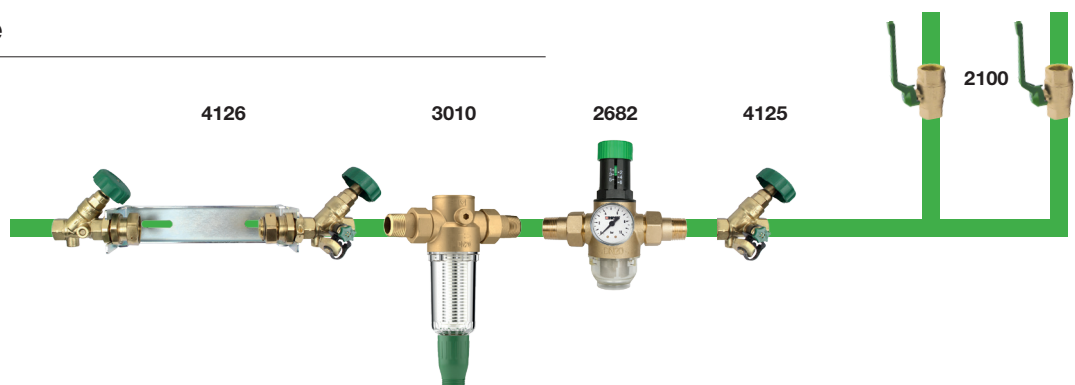

Herz Armaturen Ges.m.b.H.

Richard-Strauss-Straße 22, 1230 Vienna, Austria
 T: +43 1 616 26 31-0, F: +43 1 616 26 31-227
 E-Mail: office@herz.eu

www.herz.eu

