



# Air and Dirt Separator

---

I 1124

- ☑ high venting capacity
- ☑ separation of ferromagnetic particles without draining the system
- ☑ continuous air separation
- ☑ applicable to horizontal and vertical pipe conductions



**HERZ Armaturen GmbH**

A-1230 Vienna · Richard-Strauss-Strasse 22

Tel./Fax: +43 (0)1 616 26 31-0/-227, [www.herz.eu](http://www.herz.eu)



# HERZ I 1124 Air and Dirt Separator with Magnet

The air and dirt separator serves to separate sludge and air from the heating or cooling system. It is equipped with a sludge and dirt reduction feature that functions according to the cyclone principle. This guarantees an effective separation of the particles.

## Application area

The air and dirt separator is installed in the heating or cooling circuit (feed or return line) and serves to separate dirt and air from the heating or cooling water.

## Special product features

Air Separator: Thanks to a large internal chamber the water speed is significantly reduced and this enables the air bubbles to deposit on the internal brust and finally they vent through the air vent.

Dirt Separator: the optimal flow abatement design ensures that the contained dirt is deposited as best as possible and can be drained via the ground ball valve.

Integrated Magnet: for the collection of ferromagnetic particles, which are in the water. Separation without draining the system is possible.

Automatic Air Vent with Stop Valve: for different requirements the separator can also be combined with other air vents from the HERZ product range.

Rotatable Connector: the separator can be mounted in vertical as well as in horizontal pipes.

## Material

The air and dirt separator is made of DZR brass.

## Functional description

The air and dirt separator is used for the separation of dirt particles and air from the heating or cooling system.

For the air separation the air and dirt separator has an air vent. If air is present in the system, it rises to the highest point of the air and dirt separator. The water level drops locally there, the integrated float pulls the float arm downwards and thus opens the sealing area. The air escapes, the water level rises again and the sealing area is closed.

## Typical applications

For installation in the heating or cooling circuit to filter out dirt and sludge particles and bleed off microbubbles. This prevents malfunctions and damage to heating and cooling systems. A high efficiency for the whole heating or cooling system is ensured.

## Maintenance

A periodic maintenance for the HERZ air and dirt separator is required - depending on the nature and quality of the medium.

The lower part and the collecting chamber can be removed and the inner element can be pulled out for cleaning. Also the function of the magnet should be checked periodically.

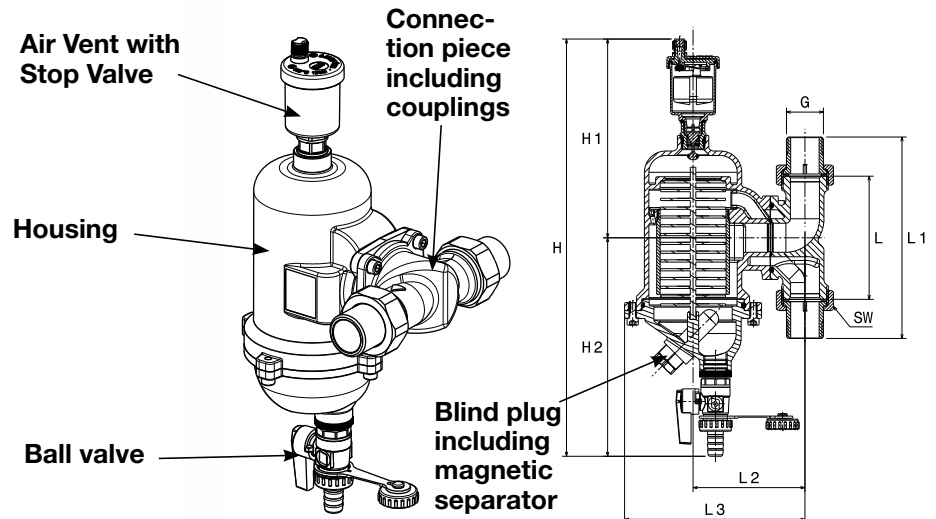

Order number	Dimension	G	L [mm]	L1 [mm]	L2 [mm]	L3 [mm]	H [mm]	H1 [mm]	H2 [mm]	SW [mm]	Nom. press.	Medium	max. temperature
I 1124 02	DN 20	3/4"	110	210	100	161	373	178	195	47	PN 10	Water and water-glycol mixture (30%)	110°C (without steam)
I 1124 03	DN 25	1"	110	180	100	161	373	178	195	47	PN 10	Water and water-glycol mixture (30%)	110°C (without steam)