

**130**  **Herz**®  
*years*

# NEWS

Issue June 2026

**INTERVIEW**  
**XENIA TICHY**  
**BETWEEN ICE**  
**AND BUREAUCRACY**  
FROM PAGE 12

**HERZ AS A**  
**PROBLEM-SOLVER**  
**CLEAN RETROFITTING OF**  
**UNDERFLOOR HEATING IN**  
**EXISTING BUILDINGS**  
FROM PAGE 8

# HERZ IN POLAND

## A REPORT

FROM PAGE 4





## Dear Readers,

Top performance is also in demand in building services engineering. At the same time, the sector has long been facing one of its greatest challenges: the shortage of skilled workers. Together with our Sales Manager for Austria, in this issue we take a look at the current market situation in Austria and explore why well-trained skilled workers are more important today than ever before.

After all, one thing is clear: progress does not happen by itself.

It is the people who master their craft, take responsibility and drive developments forward. That is precisely why this issue also takes us to Poland. In recent years, the country has developed into one of Europe's economic powerhouses and also plays an important role within the HERZ Group. It is a market that is attracting attention with its dynamism and growth.

In keeping with the season, you can also expect a refreshing look beyond the boundaries of building services engineering. The HERZ Group is delighted to count the Tichy ice cream parlour – renowned far beyond the country's borders – amongst its customers. What do a traditional Viennese ice cream parlour and an Austrian fittings manufacturer have in common? A commitment to making no compromises when it comes to quality, precision and reliability.

However diverse the topics in this issue may be, they are united by a common thread: success arises where people demonstrate their skills on a daily basis – be it on a building site, in an international growth market or behind an ice cream counter.

With this in mind, I wish you an enjoyable, relaxing summer and hope you enjoy reading this issue.

Nurgül Akbas  
Editor-in-Chief

**P.S.: Would you like to share something with us or be featured in the next issue? We welcome all feedback, suggestions and ideas from you via email at: [herznews@herz.eu](mailto:herznews@herz.eu)**

HERZ News  
Customer Magazine of Herz Armaturen Ges.m.b.H.

Owner, Publisher and Editor: Herz Armaturen Ges.m.b.H.  
A-1230 Vienna, Richard-Strauss-Straße 22  
Web: [www.herz.eu](http://www.herz.eu) | E-Mail: [herznews@herz.eu](mailto:herznews@herz.eu) | Tel: +43 1 616 26 31-0  
Editor-in-Chief: Nurgül Akbas  
Issue: June 2026

<b><u>HERZ</u></b> Poland and its charms	3
<b><u>HERZ global: Poland</u></b> A report	4
<b><u>HERZ als a problem-solver</u></b> Clean retrofitting of underfloor heating in existing buildings	8
<b><u>HERZ International</u></b> Lithuania, Romania, New Zealand, Japan	10
<b>Interview</b> <b><u>Between ice and bureaucracy</u></b> Tichy ice cream parlour	12
<b><u>Everything in its place</u></b> HERZ water flow meter fitting	15
<b>Interview</b> <b><u>Austria's skills shortage</u></b> A reality we must adapt to	16
<b><u>HERZ Pumpfix Compact</u></b> Fewer interfaces – more system	18



**Note:** For better readability, the masculine form is used for personal nouns, which of course refers to female as well as all other gender identities.

# POLAND AND ITS CHARMS



Dear customers and partners,  
dear friends of HERZ,

"The charm of the Polish woman remains unrivalled!" is the line we hear in Carl Millöcker's operetta "The Beggar Student". Premiered in Vienna in 1882, the operetta is set in Kraków in the year 1704, at a time when Augustus the Strong, Elector of Saxony and King of Poland, was on the throne. Probably the best-known number from this operetta is "Ah, I only kissed her on the shoulder". Carl Millöcker was one of the great operetta composers, alongside Franz von Suppé and, of course, Johann Strauss (the Younger).

The kissing thing won't happen, though, because our Editor-in-Chief has visually depicted the beauty on the front cover of this issue of HERZ News in line with the song lyrics – but with AI.

With AI, we're already heading towards the present. Following the partition of Poland, the country disappeared from the map for over 100 years, divided between Russia, Prussia and Austria. Having been re-established in 1918 after the First World War, Poland only regained its full sovereignty with the collapse of the Soviet Union in 1990–1991 and, with a population of almost 40 million, became a leading nation in Eastern Europe.

HERZ has been active in Poland since 1990 through its own subsidiary and has chosen the Kraków area as its base. Originally planned purely as a sales location for HERZ products, HERZ Poland very quickly became a production site for valves and boilers. In addition, our group company HIRSCH Servo AG has three production sites in Poland.

The appeal of this huge country has, of course, also attracted Western European industry and ultimately all the major competitors in the valve sector have set up production facilities in Poland. Whilst low labour costs were the initial draw, today it is above all the well-trained and motivated workforce that represents a major locational advantage.

As a legacy of the Warsaw Pact – a military alliance led by the Soviet Union – the country has a large pool of highly skilled technicians in the metalworking, electrical and electronics sectors, just as we would wish for in Austria. Furthermore, building services engineering is a degree course at university level, unlike in Austria. Also in contrast to Western Europe, the opportunity to build prosperity only arose from the 1990s onwards – a generation later than here – and, as a result, the motivation to work and earn money is very strong.

We therefore expect growth and a positive outlook for HERZ in Poland over the coming years, as well as in the other Eastern European countries.

Perhaps our magazine is not the right place for this, but Poland's role in the war in Ukraine should not go unmentioned. Almost all supplies of military and civilian aid pass through Poland, which lends the country additional weight – both internationally and within the EU. From this perspective, too, it is to be expected that the country can continue to count on substantial support for its economic development, benefiting not only its residents but also the companies that have invested and established an industrial presence there.



Gerhard Glinzerer  
CEO HERZ Group

gerhard.glinzerer@herz.eu

## HIU Renova

The perfect replacement  
for your gas boiler

The RENOVA heating interface unit has been specially developed as a direct replacement for wall-mounted gas boilers. The connection sequence, which is adapted to standard gas boilers, allows for effortless connection to existing installation pipework – without the need for any pipework modifications.

Thanks to its compact design and flexible connection options from either the top or the bottom, the system is ideal for quick replacement in existing buildings.

Efficient, time-saving and ideal for modernising gas central heating systems.



Scan now  
and learn  
more.





## HERZ IN POLAND

### A REPORT

---

Poland is now one of Europe's most dynamic industrial centres – yet the country's economic development is closely linked to a history marked by upheavals and new beginnings. Continuous growth has given rise to a market characterised by fierce competition, international pressure and, at the same time, a high level of industrial expertise. It is precisely in this environment that HERZ, with its site in Wieliczka, has successfully established itself over the decades.

#### The disappearance of Poland from the map – Liberum Veto

There are few countries in Europe whose history is as extraordinary as that of Poland. At the end of the 18th century, the country was partitioned between Russia, Prussia and Austria and disappeared completely from the map for 123 years. The reason for this was a historical instrument within the Polish-Lithuanian Sejm – the so-called Liberum Veto, which is Latin for 'free veto'. The Liberum Veto allowed a single member of parliament to immediately adjourn a parliamentary session or to declare decisions that had

already been taken invalid by raising an objection. What began as a democratic check and balance led to extreme political paralysis, rendering the state incapable of action. This was exploited by foreign powers, particularly Russia and Prussia. They bribed Polish nobles in parliament to prevent reforms in Poland, which in turn contributed to the decline of the noble republic.

A certain parallel to this political mechanism can be seen today in the United Nations Security Council. The five permanent members – the USA, Russia, China, the United Kingdom and France – have a

right of veto there. This can prevent international decisions from being taken when the interests of the major powers involved diverge.

#### The rise of a Kingdom

Despite foreign rule and political oppression, however, the Polish people preserved their language, culture and national identity. Following the end of the First World War, Poland returned to the map of Europe as an independent state in 1918. The decades that followed were marked by war, occupation and political upheaval, yet the country retained its

identity and, after 1989, developed into one of Europe's most dynamic economies.

### The white gold

Traces of this long history can still be found in many parts of the country today. One of the best-known is Wieliczka, south-east of Krakow, whose salt mine has been closely linked to Poland's economic development for centuries. Salt has been mined at the Wieliczka Salt Mine – one of the oldest in Europe – since the 13th century. Back then, salt was far more than just an ordinary seasoning: It was needed to preserve food and was regarded as one of the most valuable raw materials of its time. It was not for nothing that it was referred to as 'white gold'. For centuries, the revenue from salt mining contributed significantly to the prosperity of the Kingdom of Poland.

Today, the Wieliczka Salt Mine is a UNESCO World Heritage Site and ranks among the country's most famous attractions. Deep underground, kilometres of tunnels, underground lakes and chambers and sculptures artfully carved from salt stretch out – an impressive testament to European industrial and mining history. At the same time, they provide an extraordinary setting for cultural events, which now take place hundreds of metres below ground.

### HERZ in Poland

Following Russia's invasion of Ukraine, Poland's geographical location and its

NATO membership have made it the most important military and logistical hub for supporting Ukraine. Around 95 percent of all international military and aid shipments are handled via Rzeszów-Jasionka Airport. As a result, the country has also significantly increased its political influence in Europe. Furthermore, Poland is the largest economy in the CEE region (Central and Eastern Europe) and enjoys stable growth. This is officially confirmed by figures from the WKO. The country's attractiveness as a business location has prompted many of HERZ's competitors from the UK, Scandinavia and Austria to set up production facilities in Poland.

The HERZ Group has four sites in Poland. The country is one of the Group's largest foreign markets. In addition to the three sites operated by HIRSCH Servo (a global player in the particle foam industry and a subsidiary of the HERZ Group), there is also a HERZ branch in Wieliczka, Poland, which includes a production facility. Shortly after the political and economic changes in the country, the HERZ branch was established in Poland in 1990, thereby laying the foundations for long-term growth in the Polish market. Since then, HERZ Poland has developed into an important partner for wholesalers, planners and installers.

Furthermore, HERZ Poland benefits from Poland's strategic location at the heart of Europe and its role as a key industrial and logistics hub. In line with the company's continuous growth, production capacity has been expanded on several occasions:



Emperor Maximilian I.

**Let others wage war:  
thou, happy Austria, marry**

Rather than waging bloody wars, the Habsburgs expanded their territory from the late 15th century onwards through skilful dynastic alliances. The historical relationship between Austria and Poland was shaped above all by this. A key starting point was the marriage of Duke Ernest the Iron – also known as the progenitor of his dynasty – of the Styrian branch of the Habsburgs to Cymburgis of Masovia, a Polish Piast princess. This marriage produced eight other children as well as Frederick III, who later became Emperor of the Holy Roman Empire and permanently consolidated the Habsburgs' power.

His son Maximilian I, known as the 'last knight', perfected this policy of marriage alliances: at the Diet of Vienna in 1515, Maximilian I and the rulers of the Jagiellonian dynasty agreed on several marriage alliances, underpinned by their shared Catholic faith. At that time, the Jagiellons ruled over Poland, Lithuania, Bohemia and Hungary and were among the most powerful dynasties in Europe. When King Louis II of Bohemia and Hungary fell in the Battle of Mohács against the Ottomans in 1526, leaving no heir, the male line of the Jagiellons in his region died out. As a result of the marriage treaties concluded previously, large parts of his realm passed to the Habsburgs.

This led to a lasting shift in the centre of power in Central Europe and the House of Habsburg was able to significantly expand its position as a major European power.



**Salt sculpture of Kinga of Poland: A miner presents Crown Princess Kinga (patron saint of miners) a ring encased in a block of salt.**

In 2003, the first production hall for assembly and welding work was built. This was followed in 2008 by a further expansion to increase assembly and valve production capacity. Most recently, in 2020, the modern, automated production hall was built and all assembly activities were consolidated at a single site.

### **Building Services Engineering as a university subject**

Krakow was once the royal city and remains to this day the cultural capital of Poland, as well as one of Europe's most important centres of higher education. Jagiellonian University, AGH University of Science and Technology and the Krakow University of Technology attract students from both Poland and abroad. A large proportion of the region's skilled workforce is drawn from this strong academic environment. "Building services engineering has been firmly established at universities and technical colleges in Poland for many years. That is why, in many areas, we find staff with a sound technical background – from field staff through to planning and production. This specialist knowledge is a key factor in the development of our site," says Gerhard Glinzerer, CEO of the HERZ Group.

### **Production in Wieliczka – developed on the basis of our in-house process expertise**

The automated production and assembly facility in Wieliczka was developed and built by HERZ's own staff. The founda-

tion for this is a stable workforce that has worked together for many years – and with it, a deep understanding of the products and processes that has grown over time. "We know our products. That is why the automated assembly lines – such as those for thermostatic heads – were designed by our own engineers and built by our experienced team of mechanics," explains Grzegorz Czyżowski, Head of the Automation Department at HERZ Poland.

Here, components are assembled, tested, labelled and prepared for dispatch across two levels. Every fitting is inspected individually, rather than simply carrying out random checks. This ensures that only products meeting the high quality standards leave the factory.

What was originally developed for the company's own production processes has quickly evolved into a separate business division: HERZ Automation now also makes its expertise available to other industrial companies.

The site also includes its own welding and painting facilities. This is where components for boiler systems from HERZ Energietechnik and BINDER Energietechnik are manufactured. Particular attention is paid to quality assurance: the welding facility is ASME-certified – an internationally recognised quality standard for the manufacture and testing of pressure-bearing components, which is of particular importance for projects in North America. The site thus meets re-

quirements that can only be demonstrated by appropriately qualified companies worldwide.

### **The Polish market**

The Polish market is characterised by continuous economic growth, which brings with it intense competition between international industrial manufacturers. The lack of stable protection for domestic industry is creating considerable pressure on the market. "The culture of industrial patriotism, long established in many Western European countries, is only slowly beginning to gain ground in Poland," says Piotr Skudlarski, Managing Director of HERZ Poland.

HERZ operates in Poland as a premium European brand in the high-end market segment. "Although our products are positioned at a higher price point, their reliability and durability are proven in everyday use – particularly at a time of increasing imports from Asia," explains Skudlarski. Last year, HERZ Poland recorded significant growth in turnover, particularly in the areas of drinking water fittings, control and regulating valves, pipes and fittings. BINDER's boiler systems for district heating, industrial applications and public buildings have also attracted considerable interest.

### **Things are heating up in Poland – BINDER boilers in high demand**

With more than 100 systems installed, BINDER is now one of the established

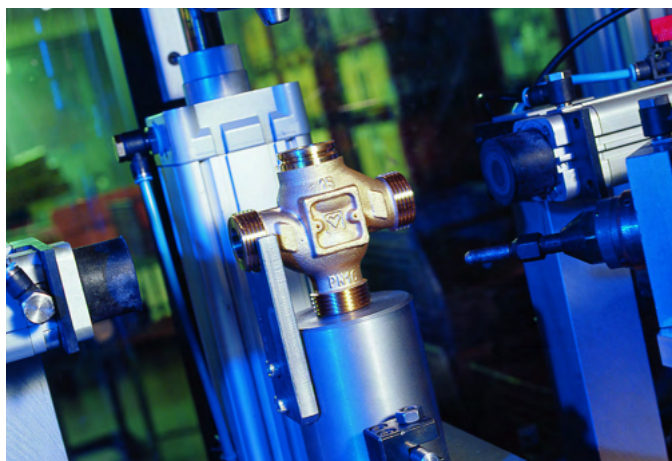

HERZ's automated production facility in Poland



In operation for 30 years: 3 MW BINDER boiler for the Kleniewski sawmill



**BINDER Energietechnik:**

A 100% subsidiary of the HERZ Group

Modern biomass-fired plants up to 10 megawatts:

- Hot water systems
- Superheated water systems
- Saturated steam systems
- Hot-air drying systems

Location: Bärnbach, Austria

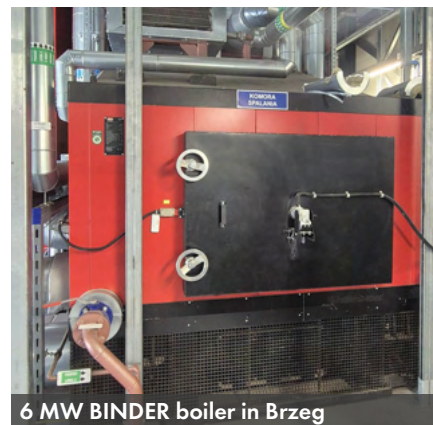

6 MW BINDER boiler in Brzeg

suppliers of biomass boilers in Poland. For around three decades, BINDER systems have been reliably supplying heat to numerous businesses in the timber and furniture industries. At the same time, BINDER is also becoming increasingly important in the field of municipal district heating, as many towns and local authorities are gradually switching their heat generation from coal to renewable energy sources. "Biomass in a heating plant – that means independence: from the weather, from fuel prices and from whatever the world's leaders happen to decide on any given day," explains Piotr Skudlarski.

The family-run Kleniewski sawmill in Bondryz provides an impressive example of the stability and durability of BINDER systems. The company processes around

12,000 m<sup>3</sup> of timber annually, of which nearly 40% is fed into one of Poland's largest drying complexes. A BINDER boiler with a capacity of 3 MW was installed at the site as early as 1996. After around twenty years of operation, the plant was relocated within the company to a second site, where it continues to operate reliably to this day. The heat supply at the main site was supplemented in parallel by a new BINDER plant for damp biomass, which has been in operation since 2016. This enables the company to utilise low-cost oak bark for energy, whilst selling higher-value sawdust and wood chips. "The boiler allows us to burn what is worth the least and sell what is worth the most," says Waldemar Kleniewski, managing director of the sawmill.

Biomass is also growing in importance in

the municipal sector. In the town of Łańcut in south-eastern Poland, with a population of just under 20,000, a BINDER boiler for wet forest biomass with a capacity of 2.5 MW was installed in 2026. Once commissioned, more than half of the district heating will come from renewable energy sources and combined heat and power generation. An electrostatic precipitator ensures low emissions.

A 6 MW BINDER biomass boiler had already been successfully commissioned in Brzeg. For many local authorities, this is not only a contribution to reducing emissions but also an economic factor: heat from biomass can be generated significantly more cheaply than heat from coal – an advantage that ultimately benefits the public. ☑

**PRIZE DRAW**



**Win a 2-day trip to Poland**

We are organising a 2-day trip to Wieliczka for two of our valued readers – including flights and accommodation. Look forward to an exclusive tour of the modern HERZ production facility and a glimpse behind the scenes of the manufacturing process. You'll also get to visit Krakow and the famous Wieliczka Salt Mine, a UNESCO World Heritage Site and one of Poland's most impressive attractions.

**How to enter:** Send an email to [herznews@herz.eu](mailto:herznews@herz.eu) by 31<sup>st</sup> August 2026 (inclusive), stating your name, company and job title – and you'll be entered into the prize draw. Optionally, we would, of course, be delighted to receive some brief feedback on HERZ News. Two winners will be drawn at random from all valid entries and notified by email.

Eligible to enter are individuals aged 18 or over who are resident in Austria and who work in the installation, heating, plumbing, planning or building services engineering sectors. Employees of the HERZ Group are not eligible to enter. Legal recourse is excluded. Multiple entries and cash redemption of the prize are not permitted. Participation is subject to the full terms and conditions, which can be requested at [herznews@herz.eu](mailto:herznews@herz.eu) and will be sent by email.



**WIN NOW:  
2 DAYS  
IN POLAND**

” On a building site, as well as functionality, it is also important that the solution fits in with the existing conditions, takes up little space and is easy to implement.

- Leon Čutura  
HERZ Planning Consultant and  
Sales Representative



## HERZ AS A PROBLEM-SOLVER

### CLEAN RETROFITTING OF UNDERFLOOR HEATING IN EXISTING BUILDINGS

---

In practice, the desire for greater comfort is increasingly reflected in the retrofitting of underfloor heating – for example, in bathrooms, toilets, hallways or as part of a flat or floor-level refurbishment. In most cases, this applies to existing radiator systems and thus presents a key technical challenge: the seamless integration of surface heating systems with low flow temperatures into a high-temperature circuit. HERZ offers various solutions for this – tailored to different renovation scenarios and requirements.

As is well known, radiators operate at higher flow temperatures than underfloor heating systems. Underfloor heating cannot therefore simply be integrated directly into an existing radiator system. This raises a typical question for plumbers in day-to-day renovation work: How can additional underfloor comfort be implemented in a technically sound manner when space is limited and existing systems must be taken into account – without resorting to improvised, bespoke solutions that may cause further

challenges later on? An additional distribution circuit, as would be used in a new build, would often be too costly and not economically viable in renovation projects where small areas are to be fitted with underfloor heating.

“It is particularly rare to find the ideal situation in renovation projects. Often, various factors arising from an existing system combine to tempt the installer into a complex and, at the same time, avoidable custom design,” reports HERZ

planning consultant and sales representative Leon Čutura, speaking from practical experience. He himself has frequently been able to help his customers with time-saving solutions that make technical and economic sense. “The key is to find solutions that can be implemented quickly on site and, at the same time, do not create any additional challenges in the long term during operation. This is precisely the aim: to provide suitable systems for a variety of renovation situations,” he concludes.

## **A** | Solution for individual room control: HERZ Floorfix Compact

If the retrofit of underfloor heating is for a clearly defined area such as a bathroom, hallway or toilet, HERZ Floorfix Compact offers the ideal solution. The product, which is supplied as a flush-mounted installation kit comprising an EPP mounting box and a cover plate, is designed for individual room control via a thermostatic valve and a return temperature limiter.

The return flow temperature limiter ensures that the fluid temperature is adjusted to meet the requirements of the underfloor heating circuit, so that a comfortable floor surface temperature can be achieved. At the same time, the user can set the room temperature as desired using the thermostatic head. In addition to its technical function, HERZ Floorfix Compact is designed to be visually timeless and suitable for any room.



Order number: 1 8100 30

## **B** | Solution for combining radiator and underfloor heating: HERZ Room Temperature Control Set

Another real-world renovation scenario involves combining radiator heating with underfloor heating in a single room. This situation often arises, for example, when a customer wishes to keep their towel radiator in the bathroom whilst also installing underfloor heating. This requirement calls for a solution that can control both heating elements – the radiator and the underfloor heating – separately and independently.

This is where the HERZ Room Temperature Control Set comes into play. The control set is designed to regulate the floor temperature via underfloor heating whilst a radiator is in use. The set comprises a dual-connection manifold,

a shut-off valve, a TS-98V thermostatic valve and a return temperature limiter – supplied as a compact flush-mounted unit with a white or chrome-plated cover plate.

The dual-connection manifold has six connections and is connected to the flow and return pipes of the radiator, the underfloor heating and the heating system (primary circuit). The return flow temperature limiter ensures that the fluid temperature is optimally adjusted for the underfloor heating. This means that both the radiator and the underfloor heating can be supplied simultaneously via the same circuit.

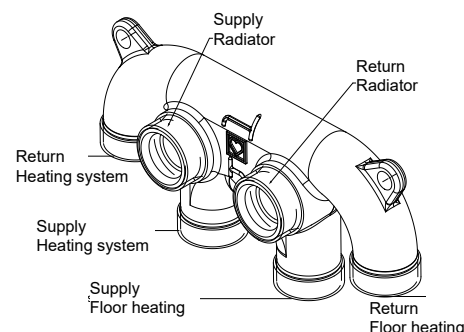

## **C** | Solution for larger renovation areas: HERZ COMPACTFLOOR

When, as part of a renovation, larger areas such as individual flats are converted to underfloor heating or additional residential units are built from scratch with underfloor heating, the following situation often arises: the existing heating system continues to operate with a high-temperature circuit, whilst the newly installed underfloor heating systems require significantly lower system temperatures.

For precisely such applications, HERZ COMPACTFLOOR offers a technically clean solution for integrating multiple underfloor heating circuits into existing high-temperature systems. HERZ COM-

PACTFLOOR is a ready-to-connect control unit comprising a high-efficiency circulation pump and a flush-mounted box for connecting between three and twelve underfloor heating circuits. Depending on the model, variants with additional radiator outlets are also available.

The prefabricated control unit combines numerous components in a compact form, such as a manifold, flow indicators, thermostatic valves, venting, drainage, a pump, mechanical temperature control, electrical components and actuators. This significantly reduces the amount of installation and commissioning work required on site and allows different heat

distribution systems to be operated reliably within a single system. ☑



Order number: 3 E532 XX

Modern technology means lower energy consumption with the same or even greater comfort—and no need to feel guilty about a warm home. That's why HERZ continuously develops innovations and efficient product solutions, ensuring this comfort remains affordable for everyone.

The Austrian HERZ Group, with its focus on energy efficiency and related production of biomass systems, heat pumps, valves, district heating stations, control technology, and insulation materi-

als, provides the products needed for efficient supply solutions—and is uniquely structured in this way within Europe.

As an Austrian company, HERZ is highly successful in the HVAC industry worldwide, with 50 subsidiaries and 44 production sites across 12 European countries. HERZ products are considered indispensable when it comes to efficient supply and long-lasting quality. For this reason, they are in high demand and successfully used around the world—from Canada all the way to the Fiji Islands.

## LITHUANIA



The Hilton Garden Inn, a subsidiary of the renowned Hilton Hotels chain, has opened its doors in the Lithuanian capital, Vilnius. The 4-star hotel boasts a prime location in the city centre, enabling guests to reach the city's attractions with ease.

HERZ Lithuania has actively supported the hotel chain by providing advice on the products required for an energy-efficient supply system. As part of this project, various HERZ products were successfully integrated, including the HERZ

pressure independent control valve, stainless steel manifolds and actuators. Each of these components was carefully selected to fulfil its specific function and role within the project. 



<input checked="" type="checkbox"/> Capital:	Vilnius
<input checked="" type="checkbox"/> Language:	Lithuanian
<input checked="" type="checkbox"/> Area:	65,300 km <sup>2</sup>
<input checked="" type="checkbox"/> Population:	2.89 million
<input checked="" type="checkbox"/> Currency:	Euro

## ROMANIA



In the Băneasa district of northern Bucharest, Cortina Elysium is taking shape as a large-scale residential development at the interface between the city and the Băneasa Forest. The project's location combines urban infrastructure with one of the capital region's most important green spaces. The project comprises 303 flats in three buildings across a total of 11 storeys and has an investment volume of around EUR 130 million. The focus is on a holistic approach to living, featuring a wellness area, fitness facilities, sports areas and a security concept.

Technically, the project is being implemented using HERZ system solutions, including underfloor heating, PipeFix for the sanitary system, HerzCON for fan coils, commissioning valves, differential pressure controllers and much more in the field of control and regulation technology. 



<input checked="" type="checkbox"/> Capital:	Bucharest
<input checked="" type="checkbox"/> Language:	Romanian
<input checked="" type="checkbox"/> Area:	238,397 km <sup>2</sup>
<input checked="" type="checkbox"/> Population:	19 million
<input checked="" type="checkbox"/> Currency:	Leu 1 € = 5.23 RON

# INTERNATIONAL



**575 million**  
Annual Revenue in Euros



**3.200**  
Employees Worldwide



**50**  
Subsidiaries



**44**  
Production Sites in 12 European Countries

## **NEW ZEALAND**



New Zealand, particular in the coastal town of Napier, was completely rebuilt following the devastating earthquake of 1931 and remains strongly characterised by its Art Deco streetscape to this day.

In the Civic Precinct – the city’s administrative and public centre – a further significant phase of urban development is now underway. The Te Aka and Maranga buildings are transforming an existing administrative and library complex into a cohesive public centre. The overall development is being supported by a green and social loan from the LGFA of up to

NZD 100 million. Based on experience from previous projects, particularly regarding quality and technical reliability in operation, HERZ products are being used for building services. In addition to the all-rounder HerzCON, components for surface heating and cooling are also being utilised.

<input checked="" type="checkbox"/> Capital:	Wellington
<input checked="" type="checkbox"/> Language:	Englisch, Maori
<input checked="" type="checkbox"/> Area:	269,652 km <sup>2</sup>
<input checked="" type="checkbox"/> Population:	5.1 million
<input checked="" type="checkbox"/> Currency:	New Zealand-Dollar 1 € = 1.96 NZD

## **JAPAN**



In Gotemba, a town approximately 100 km south-west of Tokyo, a HERZ firematic 35 wood chip plant was commissioned at Chichibunomiya Memorial Park. The park is dedicated to Prince Chichibu, the younger brother of Emperor Shōwa and a general in the Imperial Japanese Army. He is known as the prince who made a significant contribution to the promotion of Japanese sporting culture.

The centrepiece of the park is the secondary residence where the Chichinomiya imperial family lived during and af-

ter the Second World War. With an output of 35 kW, the HERZ firematic 35 provides environmentally friendly heating for a tea room and two greenhouses in the park, which are used for growing flowers.

<input checked="" type="checkbox"/> Capital:	Tokyo
<input checked="" type="checkbox"/> Language:	Japanese
<input checked="" type="checkbox"/> Area:	377,975 km <sup>2</sup>
<input checked="" type="checkbox"/> Population:	123.8 million
<input checked="" type="checkbox"/> Currency:	Yen 1 € = 186.11 JPY



Xenia Tichy, third-generation managing director of the Tichy ice-cream parlour.

## BETWEEN ICE AND BUREAUCRACY

### TICHY ICE CREAM PARLOUR

---

For decades, the family-run ice cream parlour Tichy in Vienna's 10<sup>th</sup> district has been one of the city's best-known destinations when it comes to ice cream – not just for Viennese locals, but for visitors from all over the world too. What many people don't realise, however, is that behind the iconic ice-cream sundaes, the long queues on public holidays and the nostalgic charm lies a modern production facility with sophisticated technology, clear quality standards and a family history that is still very much alive today. Xenia Tichy is the third generation to run this traditional ice cream parlour and speaks openly to HERZ News about the challenges facing Austrian businesses, cooling as a cost driver and why genuine craftsmanship is more important today than ever before.

Since 1952, the name Tichy has been synonymous with Viennese ice cream culture. What began with a three-wheeled ice cream van and five flavours of ice cream developed just a few years later into a permanent establishment in Vienna's 10<sup>th</sup> district, where the ice cream parlour has been based since 1955. Over the decades, this has grown into a traditional business with cult status, which today employs around 70 staff. Production still takes place directly at Reumannplatz – fresh, daily and without any outsourced manufacturing.

When it comes to ice cream boxes, too, Tichy relies on Austrian quality and reliability: the polystyrene ice cream boxes with high insulating properties are produced by HIRSCH Porozell GmbH, a company within the HIRSCH Servo Group, which is majority-owned by the HERZ Group. The sustainable material used is EPS – expanded polystyrene, known under the brand names Porozell or Styropor. After use, the ice boxes can be 100% recycled via the yellow bag. At HIRSCH, this is turned back into a recycled raw material, which is then reused in the manufacture of EPS products – a fun-

ctioning recycling cycle. The partnership between Tichy and HIRSCH Porozell has been a success for many decades and brings together two long-established Austrian companies that share the same values: quality, durability and continuous improvement.

**HERZ News:** Mrs. Tichy, you grew up in a family business. Was it always clear to you that you would follow this path?

**Xenia Tichy:** Not really. My parents wanted me to get a broad education first, so they sent me to grammar school. I rea-

lised fairly quickly that I wasn't the type to just sit in class and learn things by memory. So I made a conscious decision to switch to the catering industry and enrolled at a three-year vocational college. After that, I went on to train as a pastry chef – I passed my journeyman's examination and later became a master craftsman.

**HERZ News:** The 10<sup>th</sup> district doesn't always get the best press. How did it actually come to be located at Reumannplatz back then?

**Xenia Tichy:** The 10<sup>th</sup> district has much more to offer than just negative headlines. Naturally, we're delighted that Tichy is helping to ensure this district is also associated with positive experiences. My grandfather grew up in the 10<sup>th</sup> district himself and always felt a strong connection to this area. Originally, this was really just a small ice cream parlour with a shop area at the front. Step by step, my grandfather took over further parts of the premises and gradually the business as we know it today took shape.

**HERZ News:** Ice cream is traditionally very much associated with Italy. How did you manage to turn it into a genuine Viennese ice cream brand?

**Xenia Tichy:** My grandparents always used to say that back in the day, people claimed that "only Italians can make ice cream". They even learnt a few Italian phrases back then to sound more credible when talking to customers (*laughs*). At some point, though, they made a conscious decision to say: "No, we're Viennese who make ice cream" – and that's exactly how our own style came about. Our ice



Tichy Managing Director Xenia Tichy in conversation with HERZ News Editor-in-Chief Nurgül Akbas.

cream is heavily inspired by traditional Viennese confectionery – rich, high-quality and made with natural ingredients. Anyone familiar with Tichy will recognise this flavour straight away.

**HERZ News:** How do you manage to strike a balance between nostalgia and modernity?

**Xenia Tichy:** I don't think you can completely modernise a business steeped in tradition like this overnight. It's that nostalgic charm that defines Tichy. That's why, for us, modernisation often takes place behind the scenes – new cooling systems, energy-efficient technology, heat pumps and more sustainable materials such as EPS ice boxes. The familiar Tichy feel should remain visible.

**HERZ News:** Particularly in a business with enormous cooling requirements,

it is essential to follow energy-efficient production processes. What measures do you put in place to achieve this?

**Xenia Tichy:** We run a real ice cream production right in the city centre. We have four large cold stores, the largest of which is around 70 square metres. If there are any cooling losses or if the systems aren't operating efficiently, you notice it immediately in our energy consumption. That's why, in winter when the business is closed, an incredible amount of work goes into maintenance and technical optimisation. We're currently using heat pumps – partly for their efficiency, but also because we can make good use of the waste heat they generate.

**HERZ News:** Could you explain this in more detail?

**Xenia Tichy:** We use several water boilers, which are heated by a heat pump. It gets extremely hot, particularly in the basement where there is a lot of machinery. With the heat pump, we now achieve a dual benefit: we cool the room whilst at the same time using the waste heat to heat the water in the boilers. It's a real win-win system, which naturally saves us a lot on energy costs. We used to have a gas boiler.

**HERZ News:** To what extent does the issue of the skills shortage affect you as a seasonal business?



Fresh hazelnuts for pure flavour at Tichy.

**Xenia Tichy:** We employ around 70 staff. Particularly in seasonal business, it's not a given that seasonal workers will return every year, but we're really lucky here, as many of them do come back. Nevertheless, I think it's important to be honest about the shortage of skilled workers. The hospitality industry has long had a reputation for poor working conditions – excessively long working hours, days off that are frequently rescheduled or an unpleasant working atmosphere. Young people no longer accept that today and I think that's a good thing.

**HERZ News:** People tend to be very critical of the younger generation. So you see things differently?

**Xenia Tichy:** I don't believe in lumping everyone together. I think young people these days are more likely to ask themselves whether they're truly happy in their chosen career and I think that's perfectly legitimate. Work should be enjoyable and everyone should find their own path – whether that involves a degree or a trade is another matter. In my view, particularly in this age of digitalisation and AI, many people are rediscovering the value of the skilled trades.

**HERZ News:** As an Austrian family-run business, to what extent do you feel the impact of ever-increasing bureaucracy and organisational burdens?

**Xenia Tichy:** It's very demanding. Just for administrative tasks alone, you need far



**HIRSCH Porozell in the production of Tichy ice cream boxes made from EPS (expanded polystyrene).**

more staff than you used to. My grandparents had it much easier back then; they didn't see an inspector for years (*laughs*). These days, the requirements and regulations are constantly increasing, yet at the same time, companies lack points of contact that can explain the new regulations clearly and comprehensibly. The guidelines are laid down, but nobody knows exactly how they're supposed to be implemented in practice.

**HERZ News:** Lastly, if we were to discuss the partnership with HIRSCH Porozell – how would you describe it?

**Xenia Tichy:** The partnership has been in place for decades and runs smoothly. They understand our requirements perfectly, the quality is consistently high – we've designed a great product together and are very satisfied.

**HERZ News:** Mrs. Tichy, thank you very much for giving us such a candid glimpse

behind the scenes. You can really sense how much passion, technical expertise, organisation and family history have gone into this business – and why Tichy is far more than just an ice cream parlour.

### HIRSCH Servo - Solutions that go far beyond building services engineering

HIRSCH is best known in the building services sector for its energy-efficient insulation solutions for floors, walls and roofs, as well as for protective transport packaging and technical moulded parts. In addition to particle foam and fibre-moulded components, the HIRSCH Servo Group also develops energy-efficient machinery and technologies for processing particle foams, placing increasing emphasis on resource conservation, the circular economy and sustainable production processes. We show you how this sustainable circular economy is put into practice in the video – scan the QR code now to find out more. 

## HERZ ENERGIETECHNIK

### Heat pumps

Energy-efficient heat pump solutions for modern living and working.

Scan now to find out more.



commotherm SWP  
(soil-water-heat pump)  
2 - 30 kW

commotherm  
AWi-Mono  
air heat pump  
6 - 18 kW

commotherm  
SW, WW  
(soil-water;  
groundwater-  
heat pump)  
5 - 15 kW

commotherm AWP  
air heat pump  
6 - 12 kW



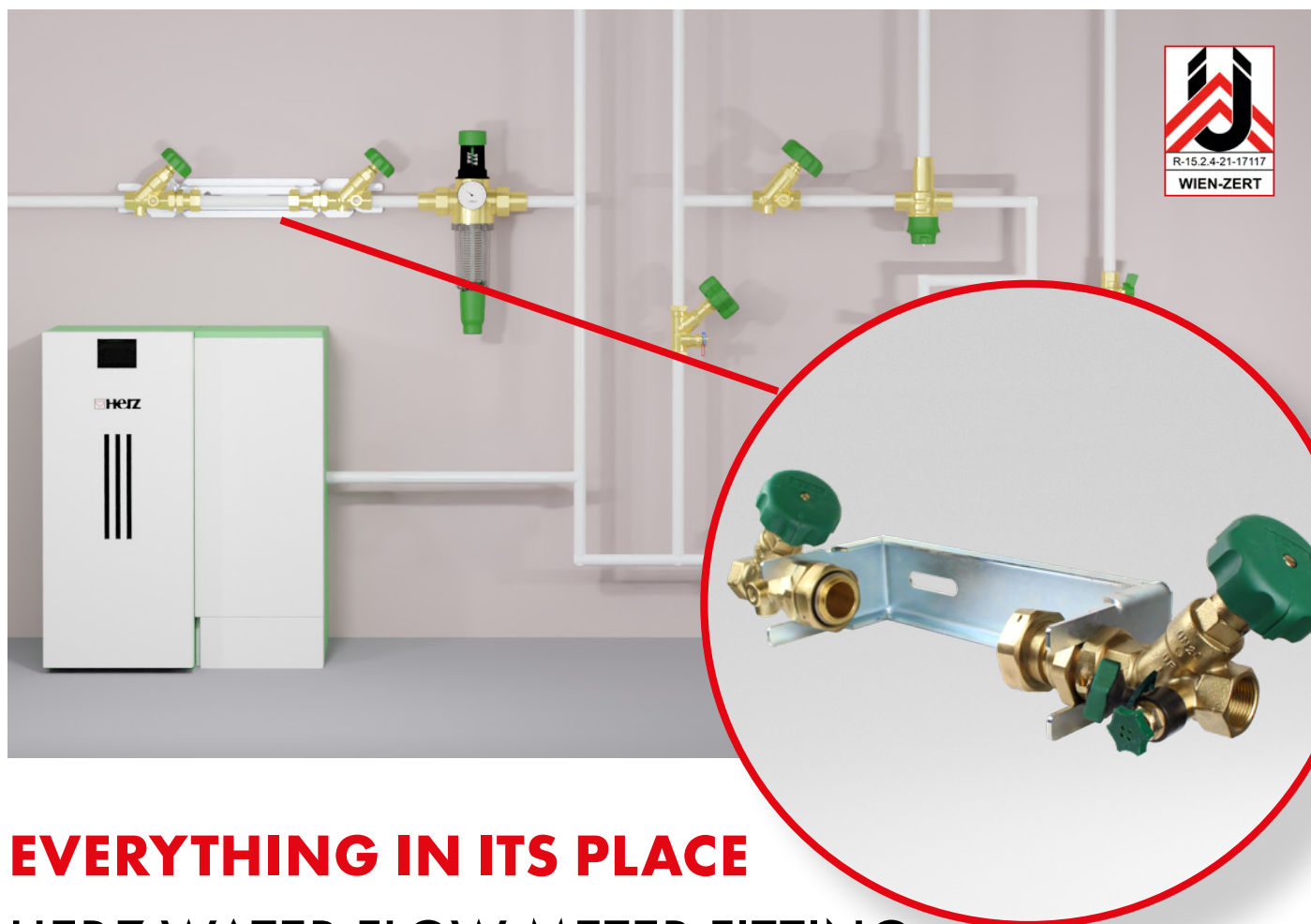

## EVERYTHING IN ITS PLACE

### HERZ WATER FLOW METER FITTING

The installation of a water flow meter is clearly defined by standards in the drinking water sector and follows a specified layout for the fittings. This prevents a simple replacement of a water meter from turning into a complex refit. Furthermore, without a clear separation before and after the water meter, any work carried out on the system would pose a risk of water loss, pressure problems or unnecessary downtime. The HERZ water flow meter fitting meets precisely these regulatory requirements in a compact, ready-to-install unit of Austrian quality – and at affordable prices.

The HERZ water flow meter fitting, compliant with ÖNORM B 2531, has been specifically designed as a compact, pre-assembled unit to meet the day-to-day requirements of plumbers working with drinking water. The water flow meter fitting includes all components defined by the standard: a shut-off valve before the water flow meter and a check valve, as well as a shut-off valve and a drain valve after the water flow meter. This makes the installation clearer and significantly reduces the effort involved.

Safety plays a key role, particularly in the drinking water sector. The integrated

check valve reliably ensures that water cannot flow back into the primary drinking water network, thereby helping to ensure that the system operates in a hygienically safe manner.

The sturdy construction, featuring an open galvanised sheet steel bracket, ensures a secure mounting base, even under recurring operational loads. The length compensation mechanism facilitates the installation of standard water meters and allows minor dimensional deviations to be easily compensated for. The union nut on the inlet side is sealable, thereby meeting additional security

and monitoring requirements. Long-lasting and reliable operation is ensured by the robust shut-off valves with non-rising spindles, including spindle seals with double O-rings. The design of the HERZ water flow meter fitting ensures a permanently secure seal, even with regular operation during normal service. At the same time, the ÜA mark certifies its approved use in the sensitive drinking water sector and underlines the high standards of quality and safety.

Further technical information is available by scanning the QR code. 



” Competition in the Austrian market has become fiercer. The pie isn't getting any bigger, but more and more people want a slice of it.

- Helmut Veigl  
HERZ Head of Sales Austria



## AUSTRIA'S SKILLS SHORTAGE

### A REALITY WE MUST ADAPT TO

---

The Austrian building services sector is under pressure: projects are being postponed indefinitely, price pressure is mounting and many companies are facing a shortage of skilled workers. The result? Tasks are increasingly being outsourced to industry: what used to be managed with technical advice now requires intensive support right from the planning stage. In an interview with HERZ News, Helmut Veigl, HERZ Head of Sales for Austria, discusses the reality of the market, the changes taking place in the field sales team and why technical expertise is more crucial today than ever before.

**HERZ News:** Mr Veigl, how do you view the current situation on the Austrian market?

**Helmut Veigl:** The pressure has increased massively. There are fewer projects, whilst at the same time more companies are competing for the same contracts. Today, large companies are bidding for smaller projects, whilst smaller firms are increasingly bidding for larger installations as well. In the past, the division was often clear-cut. The pie isn't getting any bigger, but more and more people want a slice of it. As a result, competition has become fiercer and price pressure has

risen enormously.

**HERZ News:** How does this pressure show up in practice?

**Helmut Veigl:** The impact is particularly evident in larger projects. Smaller firms can often quote more aggressively because they have lower fixed costs. However, the problem often only arises after the contract has been awarded. Some firms win projects that are barely manageable in terms of staffing. As a result, subcontractors have to be organised at short notice or work has to be outsourced. This creates additional pressure th-

roughout the entire supply chain.

**HERZ News:** At the same time, one often hears that many projects are planned but never implemented. What implications does this have for an industrial company such as HERZ?

**Helmut Veigl:** This is exactly what we have been experiencing very keenly since the start of the year. Whilst there is no shortage of project enquiries, the actual implementation of projects is proving problematic. Projects are being postponed indefinitely. This makes long-term planning extremely difficult for the

construction industry, wholesalers and plumbing contractors. In the past, entire residential complexes were built in one go. Today, construction phases are being scaled back significantly and are often only continued once units have already been sold.

**HERZ News:** How does HERZ deal with this unpredictability?

**Helmut Veigl:** We make a conscious effort to invest in technical advice and support. Our team is sometimes involved in projects as early as the planning stage – working alongside planners, plant manufacturers and installers. The technical depth of our discussions has changed completely. Customers no longer just want to know what products are available and how much they cost; they want to know what benefits they will deliver in the long term. We discuss energy efficiency, hydraulic balancing, long-term savings and system optimisation.

**HERZ News:** Why is technical advice more important than ever before?

**Helmut Veigl:** Because the shortage of skilled workers at other companies is increasingly being passed on to the manufacturing sector. Many companies have scaled back their technical capacity as a result of cost-cutting measures or are simply unable to find skilled workers any more. As a result, more and more work is being outsourced to the manufacturing sector.

**HERZ News:** To what extent have the requirements for sales changed as a result?

**Helmut Veigl:** In the past, the sales team would visit customers to present new products or provide product-specific support. Today, we are sent complete building plans so that we can configure entire heating systems. Customers expect ready-made solutions, including calculations and optimal system settings.

**HERZ News:** How is HERZ responding to this change?

**Helmut Veigl:** We are stepping up our support throughout the entire planning process – both digitally and through enhanced face-to-face advice. We have been offering installers and planners the digital planning software HERZ PROplan for some time now. The software enables the straightforward design of under-floor heating and radiator systems, as well as drinking water installations, whilst also handling the thermal building calculations. Meanwhile, we are currently expanding our sales team and are specifically looking for technically qualified building services and planning consultants.

**HERZ News:** What qualifications are required for this?

**Helmut Veigl:** We are looking for individuals with an understanding of building services engineering and technical system solutions – perhaps from a technical

college, a planning office or directly from the plumbing sector. Strong communication skills are, of course, also essential, but sales skills alone are no longer enough these days.

**HERZ News:** Does this also mean new opportunities for career changers or young professionals?

**Helmut Veigl:** Absolutely. Anyone wanting to work in the field these days needs to have a strong technical background and be able to hold their own in discussions with planners and plant engineers. The rest will follow naturally. This field is also particularly interesting for skilled workers who are looking to change career direction and want to apply their technical experience in a different environment.

**HERZ News:** In your opinion, what needs to change to ensure the industry remains stable in the long term?

**Helmut Veigl:** More cooperation. The pressure is high across the board – on manufacturers, wholesalers, designers and plumbers. In the long term, it will only work if we work more closely together again, rather than competing against one another on price.

**HERZ News:** Mr Veigl, thank you very much for your clear words and candid insights into the Austrian market. ☑

## DYNAMIC THERMOSTATIC VALVES

Precise control and automatic balancing: the combined functions of a thermostatic valve and differential pressure regulator ensure a constant flow despite pressure fluctuations—automatically and independently, with no need for readjustment. The result: the desired temperature, at the desired time, in the desired place. Achieve maximum energy efficiency with minimal effort.



# HERZ PUMPFIX COMPACT

Compact series of  
PUMPFIX pump groups  
in DN 20



## HERZ PUMPFIX COMPACT FEWER INTERFACES - MORE SYSTEM

In the day-to-day work of plumbers, a pattern repeats itself: heating and cooling systems are becoming increasingly technically sophisticated, whilst at the same time the demands on space, time and precision on site are rising. Every system consists of standard hydraulic functions – yet the traditional method of installing these components individually takes time, takes up space and increases the likelihood of mistakes. This is precisely where the new HERZ PUMPFIX Compact comes in. It combines two fully pre-assembled and independent pump groups into a compact connection solution, thereby reducing the most time-consuming steps in the installation process: the assembly, calibration and fitting of individual hydraulic components on site.

An often underestimated factor in heating and cooling technology is not only the subsequent energy efficiency, but also the efficiency of the installation process itself. Every hour saved during installation not only reduces costs but also minimises complexity on site.

In conventional systems, the hydraulic distribution consists of many individual components, each of which fulfils an important function. However, it is only the interaction between these components that makes the system operational. It is precisely this interaction that is establis-

hed factory-side in the HERZ PUMPFIX Compact.

The HERZ PUMPFIX Compact is integrated into the circuit between the heat generator and the heating or cooling circuits. All central components – such as the manifold, shut-off valves with thermometers in the flow and return lines, check valves and high-efficiency pumps – are integrated into a thermally insulated pump unit and coordinated with one another.

Acting as a hydraulic interface, this pump unit supplies the individual functional

areas and ensures that water circulates reliably at the correct temperatures. In practice, this shifts the focus to what really matters – away from the installation of individual components and towards functional system integration.

### Day-to-day operational requirements

The key feature of the HERZ PUMPFIX Compact is the combination of two independently operating pump groups in a single unit. Depending on requirements, these can be configured as two mixing circuits, two direct circuits or a combina-

tion of both. This flexibility is particularly crucial, as systems rarely have uniform usage requirements. Part of the system often requires a controlled flow temperature, for example for underfloor heating or combined heating and cooling systems. In such cases, the mixing circuit comes into play, continuously adjusting the fluid temperature via a three-way valve and an external controller. The defined flow temperature is achieved by the controlled mixing of cool return water into hot flow water.

In parallel, a second circuit can be designed as a direct circuit, which operates without temperature mixing and transfers the heating water directly from the heat generator to the consumer. Typical applications include conventional radiator circuits or boiler charging.

Combining both principles in a single unit enables a clear separation of different hydraulic requirements within a system.

### Two pump units, a wide range of applications

A combination of different pump groups is possible for HERZ PUMPFIX Compact in the following scenarios:

#### For two mixing circuits:

Two PUMPFIX Mix pump units are used for this purpose. These are designed for systems where active temperature control is required. They operate with a mixing motor and enable precise adjustment of the flow temperature via a 3-point control system. They ensure stable and energy-efficient operating conditions, particularly in underfloor heating systems or combined heating and cooling systems.

#### For two direct circuits:

Two PUMPFIX Direct pump units are in use. These establish a direct connection between the heat generator and the heating circuit. Thanks to the shut-off valve acting as a connection component, the pump can also be replaced with ease.

#### For the combination of a mixed circuit and a direct circuit:

For applications requiring both a controlled mixing circuit and a directly supplied heating circuit, the HERZ PUMPFIX Compact is designed as a combination of a PUMPFIX Mix and a PUMPFIX Direct pump unit.

### Can be flexibly adapted, even in the event of subsequent changes

In all variants, the pump groups in the HERZ PUMPFIX Compact are connected to one another via a common manifold. Depending on the system requirements, the manifold can be used either as a pressurised manifold or as a hydraulic separator. This adaptability allows for flexible integration into various heating systems and facilitates the hydraulic balancing of the entire system.

The function of the hydraulic separator is particularly required in systems with an additional supply pump in the primary heating circuit. It ensures hydraulic decoupling between the flow and return pipes and balances out differences in flow rates between the primary and secondary circuits. As a result, each circuit operates independently within its optimal operating range, whilst at the same time improving the stability and controllability of the entire system.

This modularity is particularly important in an environment where requirements often change during the construction phase or later in operation. Instead of rebuilding the entire system from scratch, the existing structure can be expanded or adapted without losing the basic hydraulic architecture. ☑

### Components

Valve with thermometer with integrated check valve (blue)

Spacer with check valve

Ball valve  
Easy conversion to a mixing circuit is possible

Combined manifold–separator module

Return flow

Valve with thermometer (red)

Circulation pump  
Wilco Para 15-130/6  
can be ordered with or without a pump

Mixing valve  
with motorised actuator

Supply flow

Hydraulic switch changeover

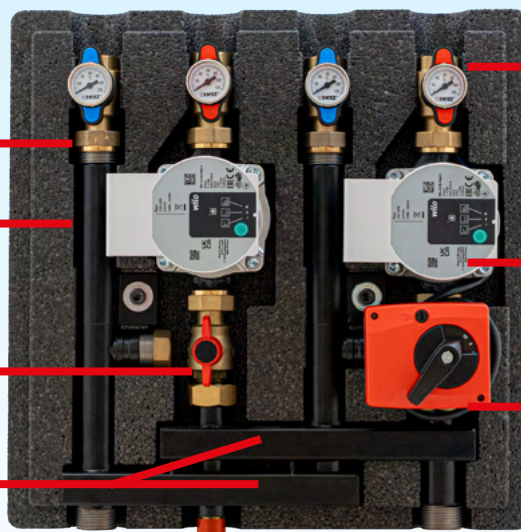

Scan now to find out more.

130  **HERZ**®  
*years*

## Drinking water with HERZ

### Protecting installations against excessive inlet pressure

Thanks to its innovative flow design, the patented membrane pressure reducer ensures precise pressure regulation and constant pressure – even at high flow rates. Available with or without a drinking water filter.



**PATENTED**





Return: HERZ Armaturen Ges.m.b.H., Richard-Strauss-Straße 22, A-1230 Vienna



Herz Armaturen Ges.m.b.H.  
Richard-Strauss-Straße 22, A-1230 Vienna  
T: +43 1 616 26 31-0  
E-Mail: [herznews@herz.eu](mailto:herznews@herz.eu)  
[www.herz.eu](http://www.herz.eu)

 HERZ Armaturen GesmbH - Wien  
 Herz Armaturen Ges.m.b.H.

 [herz.armaturen](https://www.instagram.com/herz.armaturen)

 [Herz Armaturen Ges.m.b.H.](https://www.facebook.com/HerzArmaturen)



*the Heart of technology*