

# HERZ Calis-TS Three way valves

for one-pipe systems

Datasheet 7761 Calis, Issue 0923

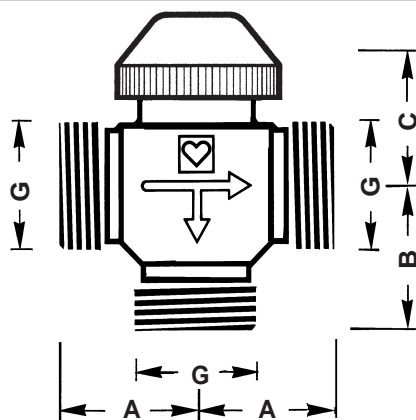

7761

Dimensions in mm

Model	Order No.	Dimension	G	A	B	C	kvs	dp (bar) max.
Calis TS	1 7761 01	1/2	3/4	30	30	22	2,75	0,20
Calis TS	1 7761 02	3/4	1	37,5	34	22	3,2	0,20

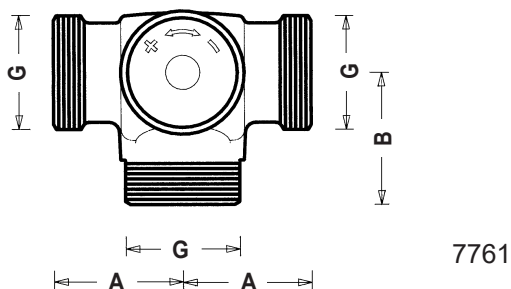

7761

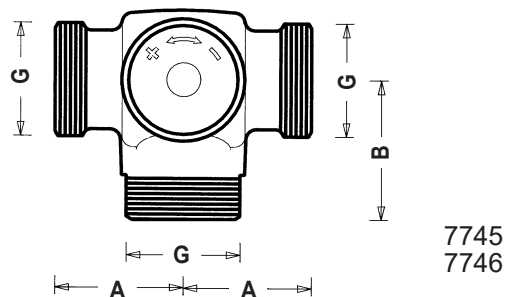
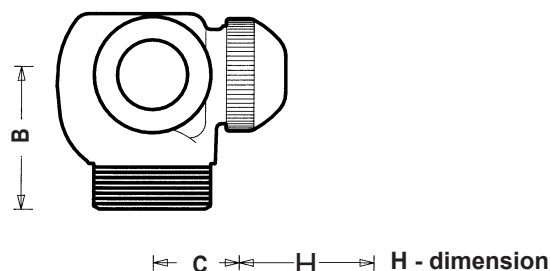

7745  
7746

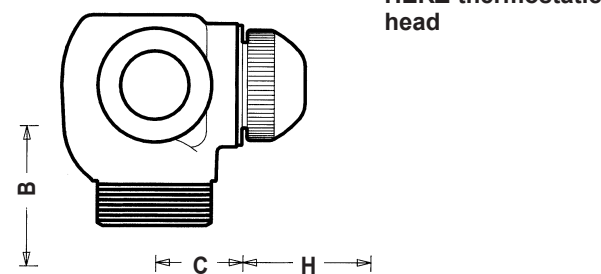

Dimensions in mm

Modell	Order No.	Position on the radiator	DN	G	A	B	C	kvs	dp (bar) max.
CALIS-TS-3-D	1 7761 43	left	1/2	3/4	30	30	29	3,5	0,2
CALIS-TS-3-D	1 7761 44	right	1/2	3/4	30	30	29	3,5	0,2
CALIS-TS-3-D	1 7761 45	left	3/4	1	37,5	38,5	24,5	4,2	0,2
CALIS-TS-3-D	1 7761 46	right	3/4	1	37,5	38,5	24,5	4,2	0,2
CALIS-TS-E-3-D	1 7745 02	left	3/4	1	37,5	41	32,5	4,42	0,2
CALIS-TS-E-3-D	1 7746 02	right	3/4	1	37,5	41	32,5	4,42	0,2

### Field of Application

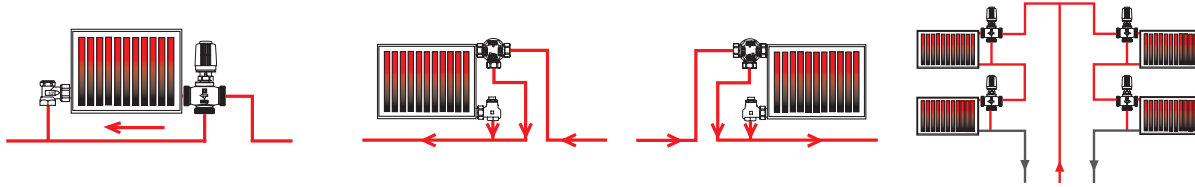

### Installing the Thermostatic Valve

When planning the system please note that the HERZ thermostatic head should wherever possible be installed horizontally in order to ensure optimum control of the room temperature and at the same time minimise disturbances. If this is not possible the HERZ thermostat with remote sensor or remote control should be used.

Under no circumstances should the HERZ thermostatic head be exposed to direct sunlight or equipment that emits relevant quantities of heat – e.g. television sets. If the radiator is covered (e.g. by curtains), this will cause heat accumulation zones in which the thermostat cannot sense the room temperature and cannot therefore control it. In these cases, use HERZ thermostats with remote sensor or remote control.

Refer to the appropriate standard sheets for details of HERZ thermostats.

### Summer Setting

After the end of the heating period open the valve completely by turning it in an anti-clockwise direction to prevent dirt deposits at the valve seat.

### Material

Brass valve body, stainless steel spindle, EPDM seals.

HERZ Calis-TS are supplied in a nickel-plated version, all with a white screw cap and without connections.

Thermostat connection thread M 28 x 1.5 HERZ.

### Operating Data

Max. operating temperature 120 °C

Max. operating pressure 10 bar

Max. differential pressure in thermostatic operation 0,2 bar

Hot water quality conforming to ÖNORM H 5195 and/or VDI guideline 2035.

No hemp should be used for thread sealing because the ammonia contained in hemp can damage the brass. It is recommended to use sealing strip. EPDM seals are swollen by mineral oils or lubricants containing mineral oil and thus lead to failure of the EPDM seals. For frost and corrosion protection agents based on ethylene and propylene glycol can be found in the manufacturer's documentation.

When using HERZ compression unions for copper and steel pipes, observe the permissible temperatures and pressures as specified in EN 1254-2: 1998 Table 5. For press fittings HERZ-PIPEFIX, the maximum operating temperature is 95 °C and the maximum operating pressure is 10 bar.

### Installation of CALIS-TS

During installation please observe the flow direction. It is marked by arrows on the valve body.

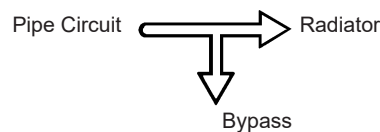

### Function

HERZ Calis-TS distribution valves are suitable for use as thermostatic one-pipe valves for radiators to control the room temperature in closed hot water heating circuits with approximately constant volume flows. When the thermostat valve is open, the through branch and the distribution branch of the valve are open; if the valve is closed by a thermostat or thermal drive, the through branch is closed.

### Other Models

**7761 RD** DN 15, 20, 25, 32 HERZ thermostatic three-port valve, distribution 100 %

**7762** DN 10,15,20 HERZ thermostatic three-port control valve for mixing and distribution

**4037** DN 15 - 50 HERZ 3-port mixing and diverting valve

Separate datasheets are available for these versions.

### ☑ Pipe connection

The delivery scope of HERZ flat-sealing screw connections always includes a nut, connection and seal.

### ☑ Changing the Upper Part of the Valve

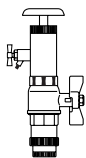

The CALIS-TS and CALIS-TS-E upper part can be changed under pressure by means of the HERZ changing device Changefix 7780.

In this way any problems occurring at the seat seal, e.g. accumulation of foreign substances such as dirt, welding and soldering residues, can be easily resolved.

When using the HERZ changing device 1 7780 00 please refer to the operation instructions supplied with it.

### ☑ Thermostatic operation

All HERZ thermostats as well as the components of the electronic control systems HERZ-RTC (room temperature computers, DDC actuators) and HERZ-RTR (room thermostats, thermal motors) can be used to control the upper thermostat parts.

### ☑ Spindle Seal

An O-ring is used as a spindle seal. It is located in a brass chamber which can be changed during operation.

The O-ring keeps maintenance requirements at a minimum and permits smooth valve operation over a long period of time.

#### Changing the O-Ring

1. Dismantle the HERZ thermostatic head and/or HERZ-TS-handwheel.
2. Then, unscrew the O-Ring chamber including the O-Ring and replace it with a new one. When doing this, use a wrench to hold the upper part. During dismantling, the valve is completely open and therefore sealing tight towards upstream. However, a few drops of water may leak out.
3. For re-assembly follow the above mentioned steps in reverse sequence. When installing the HERZ-TS-handwheel, turn to make sure that the valve closes.

Order Number for O-Ring set: 1 **6890 00**

#### Seat seal

The valve cone is equipped with a soft seal, designed to meet the requirements of thermostatic operation.

### ☑ HERZ-Thermostatic Valve Nominal stroke



The screw cap serves for operation during the installation phase (pipe flushing). The thermostatic valve is formed by removing the screw cap and screwing in the HERZ thermostatic head without draining the heating system.

Setting the nominal lift with the screw cap:

On the knurled part of the circumference of the screw cap there are two setting marks (webs) in alignment with the “+” and “-” marks.

1. Close the valve by turning the screw cap clockwise.
2. Mark the position corresponding to the setting mark “+”.
3. Turn the screw cap anti-clockwise until the setting mark “-” is at the position marked under item 2.

### ☑ HERZ-TS Handwheel



In the exceptional case that the HERZ thermostatic valve lower part is not equipped with a HERZ thermostatic head, the HERZ-TS handwheel 1 **9201 80** is used to replace the screw cap.

During installation, follow the instructions enclosed with the handwheel.

### ☑ Accessories

- 1 **7262 00** HERZ thermostatic head for elevated flow rates in proportional range
- 1 **1001 02** CALIS flow T-piece DN 20  
The flow T-piece is used on one-pipe radiators with a CALIS-TS three-way valve to connect the radiator return pipe hydrodynamically.
- 1 **6807 90** HERZ-TS-90 assembly key
- 1 **7780 00** HERZ-Changefix, changing tool for thermostatic upper parts
- 1 **9102 80** HERZ-TS-Handwheel

**Spare Parts**

- 1 6329 01 Thermostat upper part for CALIS-TS
- 1 6329 11 Thermostat upper part for CALIS-TS, 3-D-model
- 1 6329 22 Thermostat upper part for CALIS-TS-E, 3-D-model
- 1 6890 00 HERZ-TS-90 O-ring-set

**kv-Values**

Characteristics	CALIS-TS valve	kv-value	Water distribution to radiator %	Operational status
1	1 7761 01	1,45	00	Valve closed towards radiator
2	1 7761 02	1,65		
3	1 7761 01	1,60	50	Thermostatic operation xp = 2 K
	1 7761 02			
	1 7761 01	1,80	60	Thermostatic operation xp = 3 K
	1 7761 02			
4	1 7761 01	2,75	80	Valve open
5	1 7761 02	3,20		

**kv-Values**

Characteristics	CALIS-TS		CALIS-TS-E
	1 7761 43 1 7761 44	1 7761 45 1 7761 46	1 7745 02 1 7746 02
1 K	1,6	1,90	2,96
2 K	2,0	2,25	3,33
3 K	2,4	2,50	3,63
open	3,5	4,20	5,28

**Distribution via the radiator**

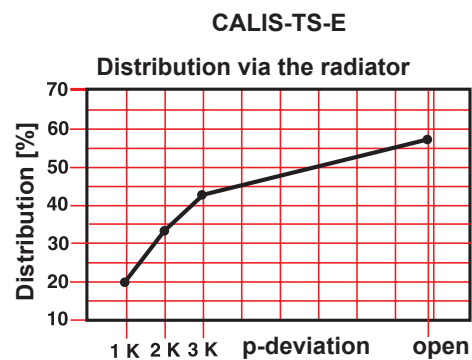
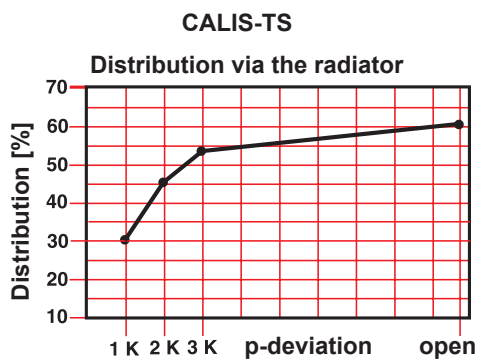

**Materials note**

Pursuant to Article 33 of the REACH Regulation (EC No. 1907/2006), we are obliged to point out that the material lead is listed on the SVHC list and that all brass components manufactured in our products exceed 0.1% (w / w) lead (CAS: 7439-92-1 / EINECS: 231-100-4). Since lead is a component part of an alloy, actual exposure is not possible and therefore no additional information on safe use is necessary.

**Disposal**

Local and currently applicable legislation must be observed for disposal. The disposal of HERZ CALIS-TS valves must not endanger the health or the environment.

HERZ-Standard diagram	CALIS-TS
Art. No. <b>7761</b> 01/02	Dim. R = 1/2 • R = 3/4

Valve dimensioning [ $\Delta p$ ] shall be performed in accordance with the "VDMA-Instruction Sheet for Planning and Hydraulic Balancing of Heating Systems with Thermostatic Radiator Valves".

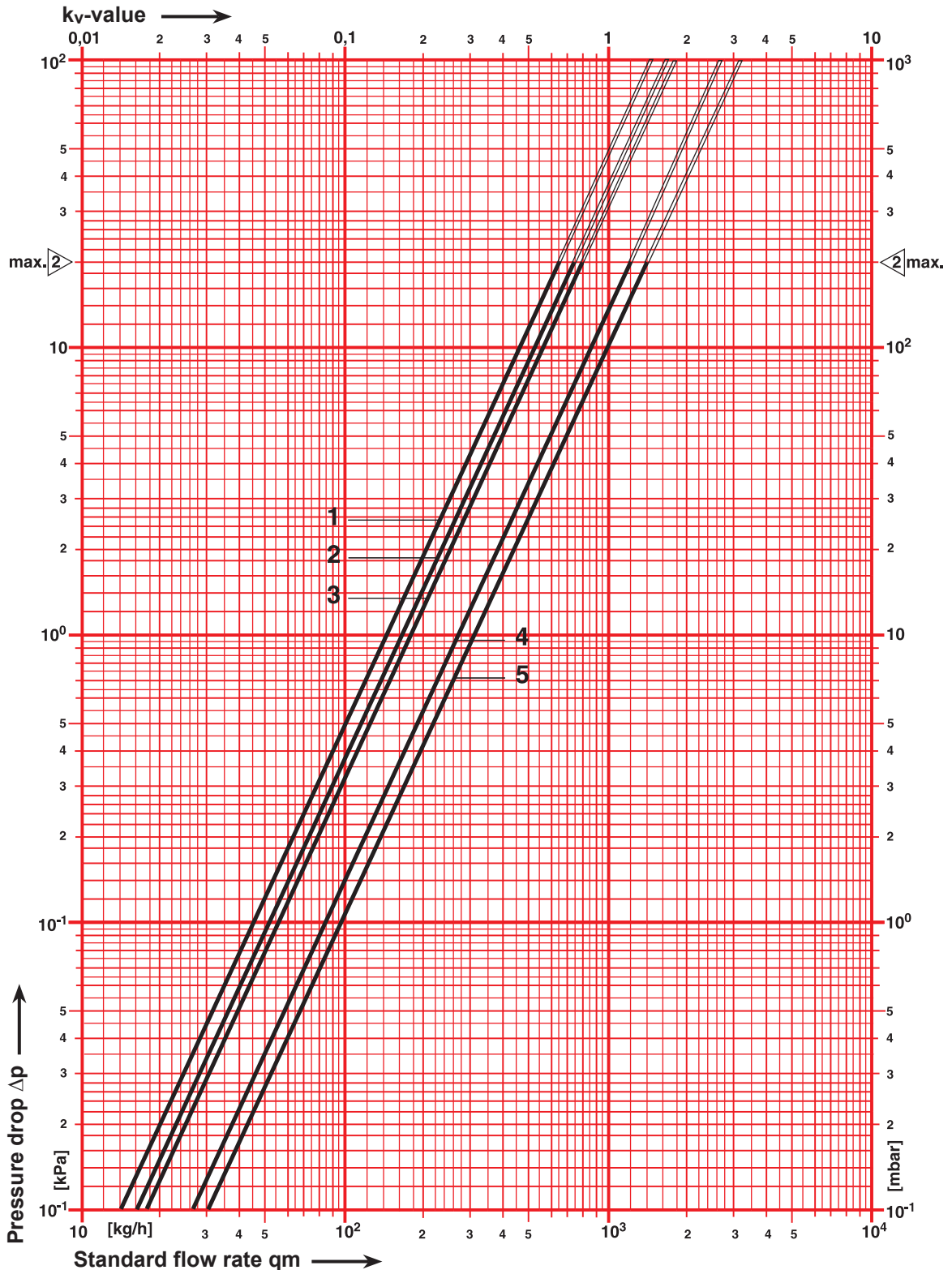

HERZ-Standard diagram	CALIS-TS
Art. No. 1 7761 43 • 1 7761 44	Dim. R = 1/2

Valve dimensioning  $[\Delta p]$  shall be performed in accordance with the "VDMA-Instruction Sheet for Planning and Hydraulic Balancing of Heating Systems with Thermostatic Radiator Valves".

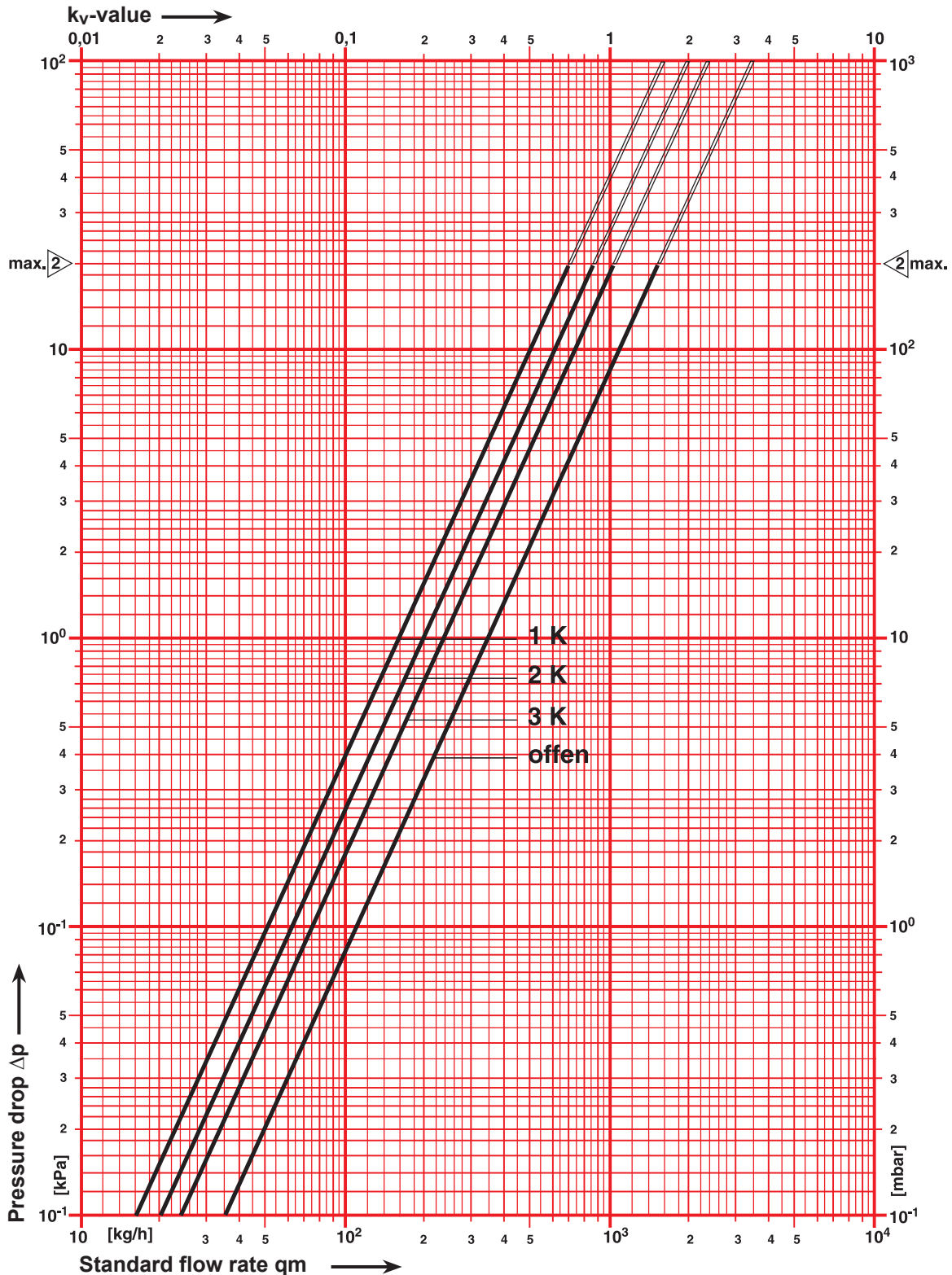

HERZ-Standard diagram	CALIS-TS-E
Art. No. 1 7761 45 • 1 7761 46	Dim. R = 3/4

Valve dimensioning [ $\Delta p$ ] shall be performed in accordance with the "VDMA-Instruction Sheet for Planning and Hydraulic Balancing of Heating Systems with Thermostatic Radiator Valves".

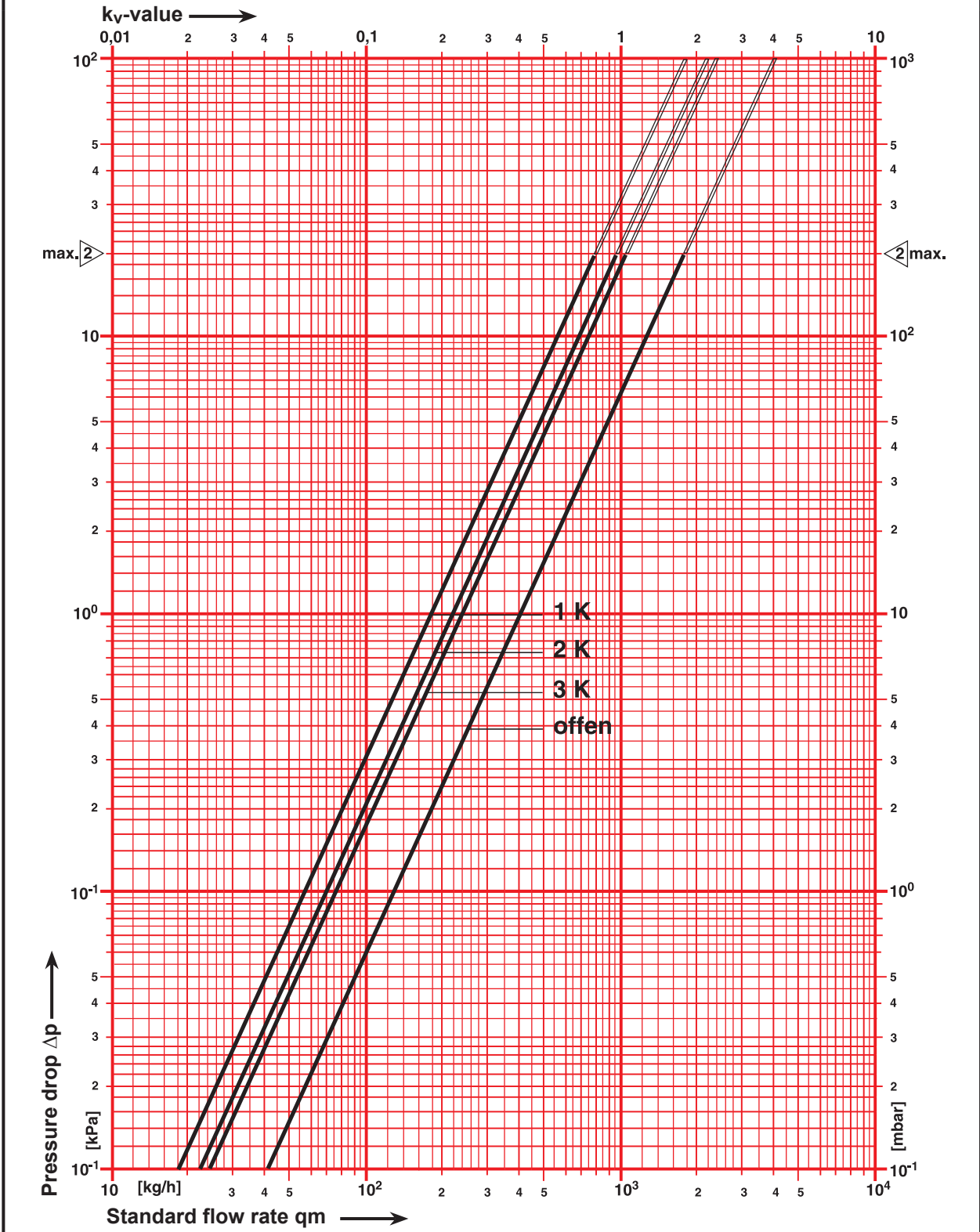

HERZ-Standard diagram	CALIS-TS-E
Art. No. 1 7745 02 • 1 7746 02	Dim. R = 3/4

Valve dimensioning [ $\Delta p$ ] shall be performed in accordance with the "VDMA-Instruction Sheet for Planning and Hydraulic Balancing of Heating Systems with Thermostatic Radiator Valves".

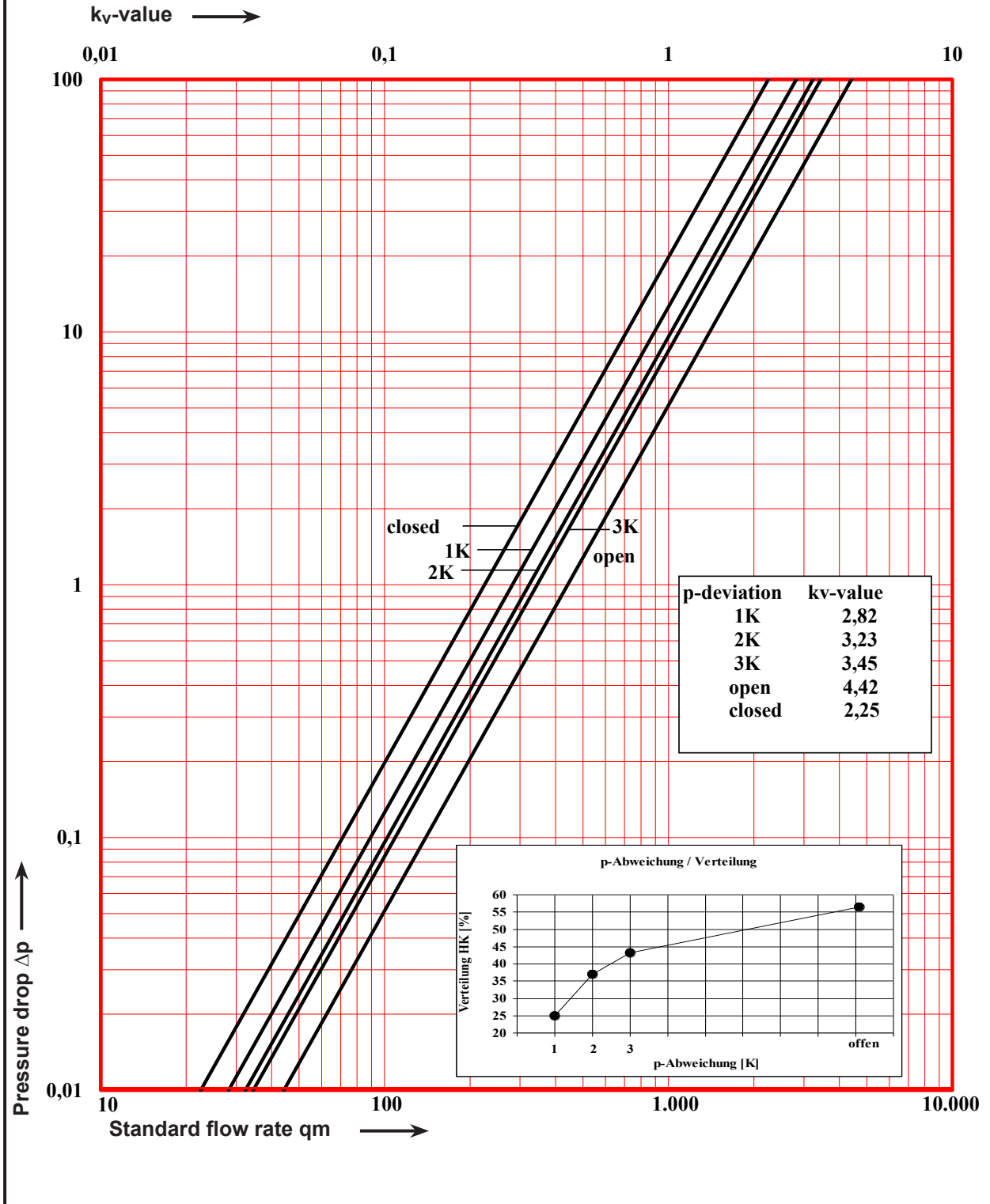

Flow T-piece and connections

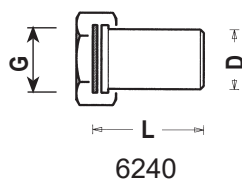
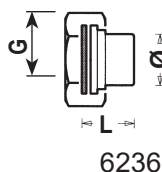
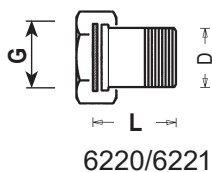

Valve dimension	Order number	G	D	∅	L
DN 15	1 6220 21	3/4	1/2	-	30
DN 15	1 6220 11	3/4	1/2	-	38
DN 20	1 6220 12	1	3/4	-	34
DN 20	1 6220 22	1	3/4	-	44
DN 20	1 6221 02	1	1/2	-	33
DN 15	1 6236 11	3/4	-	15	17
DN 15	1 6236 01	3/4	-	12	14
DN 15	1 6236 21	3/4	-	18	19
DN 20	1 6236 22	1	-	22	23
DN 20	1 6236 02	1	-	15	18
DN 20	1 6236 12	1	-	18	19
DN 15	1 6240 01	3/4	-	21	45
DN 20	1 6240 02	1	-	27	45

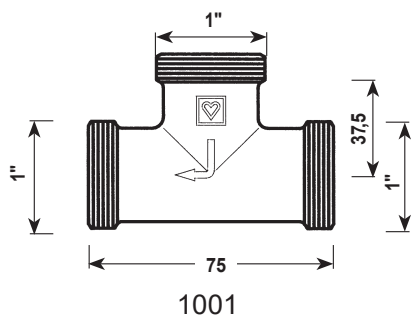

1 1001 02 DN20 Flow T-piece, nickel plated, with flat seal. Pipe connections must be ordered separately. The flow T-piece is used on one-pipe radiators with a CALIS-TS three-way valve to connect the radiator return pipe hydrodynamically.

Junction press fitting screw connection, flat-sealing

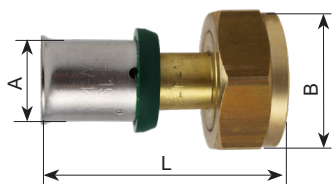

Valve dimension	Order number	B	A	L
DN 15	T 7016 41	G 3/4	16 x 2	42
DN 15	T 7020 41	G 3/4	20 x 2	42
DN 15	T 7026 41	G 3/4	26 x 2	42
DN 20	T 7016 42	G 1	16 x 2	35
DN 20	T 7020 42	G 1	20 x 2	35
DN 20	T 7026 42	G 1	26 x 3	35

All specifications and statements within this document are according to information available at the time of printing and meant for informational purpose only. Herz Armaturen reserves the right to modify and change products as well as its technical specifications and/or its functioning according to technological progress and requirements. It is understood that all images of Herz products are symbolic representations and therefore may visually differ from the actual product. Colours may differ due to printing technology used. In case of any further questions don't hesitate to contact your closest HERZ Branch-office.