

Datasheet Collection. Flanged 2-Port and 3-Port Valves.

Datasheet „2-Port and 3-Port Valves, flanged“, Issue 1125

Table of contents

HERZ-2-Port-Flanged Valves	2
HERZ-3-Port-Flanged Valves	6
Actuators selection matrix.....	9

General information

Intended Use

This product is intended to be used as specified by the manufacturer, described in the „Functional Description“ section. Local product regulations must be taken into consideration. Changes are not permitted.

Disposal

Disposal must comply with local and current legislation. Prior to the assembly, maintenance and disassembly, the system must be depressurized, cooled down and emptied. Only authorized, trained and qualified personnel may perform activities of assembly, start-up, operation and disassembly of the equipment. Before disposal the valve must be dismantled into groups of structural components and delivered to authorized waste recycling organizations in order to preserve the environment. Local legislations must be obeyed when disposing of the components.

Note

All schemes are symbolic and not exhaustive.

Material

Pursuant to Article 33 of the REACH Regulation (EC No. 1907/2006), we are obliged to point out that the material lead is listed on the SVHC list and that all brass components manufactured in our products exceed 0.1% (w / w) lead (CAS: 7439-92-1 / EINECS: 231-100-4). Since lead is a component part of an alloy, actual exposure is not possible and therefore no additional information on safe use is necessary.



Declaration of Conformity

HERZ Armaturen Ges.m.b.H hereby declares that the product F **4037** 01-41; F **4035** 01-52 is in compliance with the essential requirements and other relevant provisions of the directives 2014/68/EU, EN 60534 and EN 12516-2. The original of the conformity assessment is available upon request.

Please note: all diagrams are indicative in nature and do not claim to be complete.

All specifications and statements within this brochure are according to information available at the time of printing and meant for informational purpose only. Herz Armaturen reserves the right to modify and change products as well as its technical specifications and/or its functioning according to technological progress and requirements. It is understood that all images of Herz products are symbolic representations and therefore may visually differ from the actual product. Colours may differ due to printing technology used. In case of any further questions don't hesitate to contact your closest HERZ Branch-office.

HERZ-Two-Port-Flanged Valve

F 4035 XX

Datasheet „2-Port Valves, flanged“ PN 16 and PN 25

☑ Dimensions in mm (PN16)

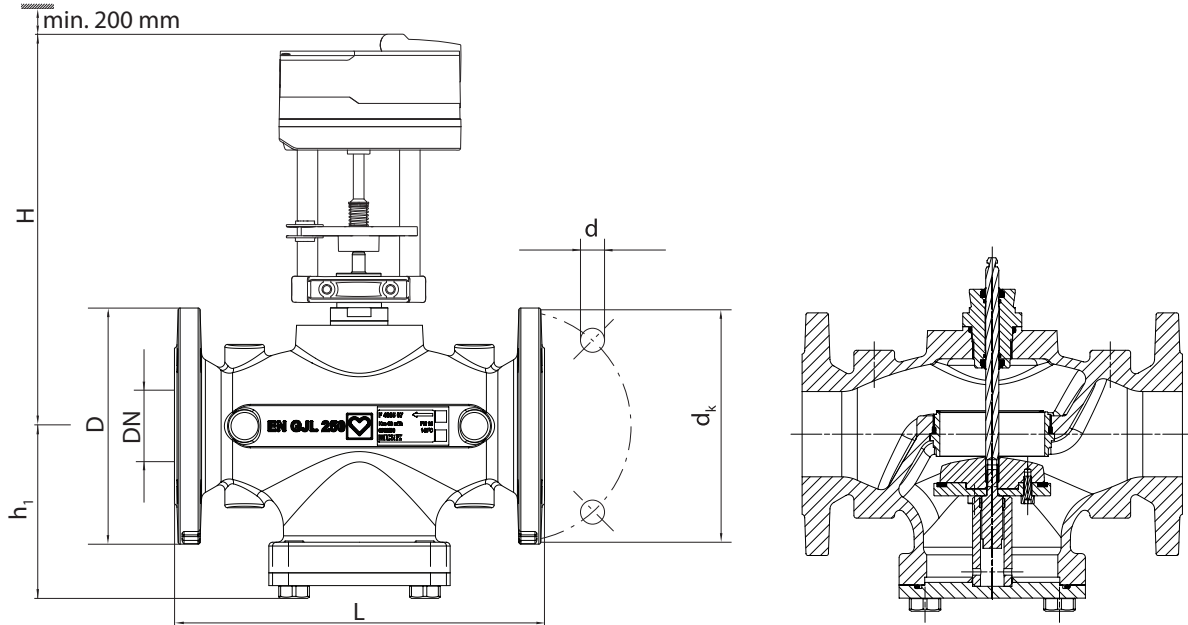

Order Nr. PN 16	DN	Stroke [mm]	kvs	D	L	Number of flange bores	d	d _k	h ₁	H	kg	
F 4035 01	15	10	1	95	130	4	14	65	68	250	4,5	
F 4035 11	15	10	1,6	95	130			65	68	250	4,5	
F 4035 21	15	10	2,5	95	130			65	68	250	4,5	
F 4035 31	15	14	4	95	130			65	68	250	4,5	
F 4035 03	25	20	6,3	115	160			85	85	255	7,5	
F 4035 13	25	20	10	115	160			85	85	255	7,5	
F 4035 04	32	20	16	140	180	8	19	100	105	305	10,5	
F 4035 05	40	20	25	150	200			110	115	315	11	
F 4035 16	50	20	40	165	230			125	90	305	12,5	
F 4035 07	65	20	63	185	290			145	135	315	20	
F 4035 08	80	20	100	200	310			160	150	350	26	
F 4035 09	100	40	160	220	350			180	160	480	38	
F 4035 10	125	40	250	250	400	12	23	210	185	520	64	
F 4035 41	150	40	330	285	480			230	180	525	77	
F 4035 42	200	40	630	340	600			230	295	236	559	161
F 4035 54	250	40	710	405	730			280	355	245	550	190

☑ Dimensions in mm (PN25)

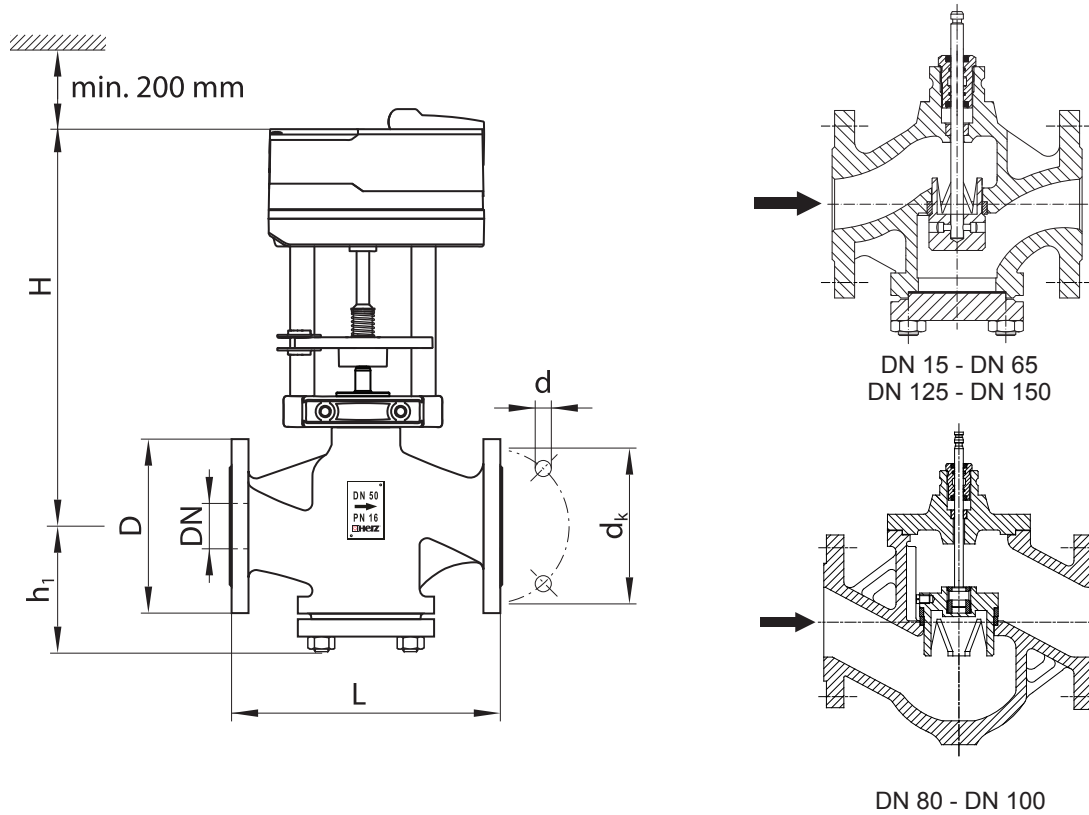

Order Nr. PN 25	DN	Stroke [mm]	kvs	D	L	Number of flange bores	d	dk	h ₁	H	kg
F 4035 40	15	10	1	95	130	4	14	65	68	250	4,5
F 4035 51	15	10	1,6	95	130			65	68	250	4,5
F 4035 61	15	10	2,5	95	130			65	68	250	4,5
F 4035 71	15	14	4	95	130			65	68	250	4,5
F 4035 43	25	20	6,3	115	160			85	85	255	7,5
F 4035 53	25	20	10	115	160			85	85	255	7,5
F 4035 44	32	20	16	140	180	8	19	100	105	305	10,5
F 4035 45	40	20	25	150	200			110	115	315	11
F 4035 56	50	20	40	165	230			125	125	320	12,5
F 4035 47	65	40	63	185	290			145	132	465	25
F 4035 48	80	40	100	200	310			160	105	510	34
F 4035 49	100	40	160	235	350			23	190	127	540
F 4035 50	125	40	250	270	400	28	220	170	505	65	
F 4035 52	150	40	330	300	480		250	180	545	84	

PN16				Leakage acc. to 12266-1
Order number	DN	Differential pressure max. [bar]		Direct flow branch
F 4035 01	15	4		≤0.01%kvs
F 4035 11	15	4		
F 4035 21	15	4		
F 4035 31	15	4		
F 4035 03	25	4		
F 4035 13	25	4		
F 4035 04	32		4	
F 4035 05	40		4	
F 4035 16	50		3	
F 4035 07	65		1.5	
F 4035 08	80		1.5	
F 4035 09	100		2	
F 4035 10	125		1	
F 4035 41	150		1	
F 4035 42	200		0.5	
F 4035 54	250		0.5	

PN25				Leakage acc. to 12266-1
Order number	DN	Differential pressure max. [bar]		Direct flow branch
F 4035 40	15	4		≤0.1%kvs
F 4035 51	15	4		
F 4035 61	15	4		
F 4035 71	15	4		
F 4035 43	25	4		
F 4035 53	25	4		
F 4035 44	32		4	
F 4035 45	40		4	
F 4035 56	50		3	
F 4035 47	65		2.5	
F 4035 48	80		2.5	
F 4035 49	100		2	
F 4035 50	125		1	
F 4035 52	150		1	

☑ Technical data and material

Max. operating pressure	16 bar (PN16), 25 bar (PN25)
Min. operating temperature	5 °C
Max. operating temperature	150 °C
Valve curve characteristic	equal percentage
Type of connection	Flanges (EN 1092-2)
Valve body material for PN16	EN-GJL-250 (EN 1561)
Valve body material for PN25	EN-GJS-400-18-LT (EN 1563)
Sealing element material	70EPDM
Valve seat material	WN1.4021
Valve cone material (PN16)	WN1.4021/brass
Valve cone material (PN25)	
up to DN 50	WN1.4021
from DN 65 to DN 150	EN-GJL-250/WN1.4021
Stem material	WN1.4404

Water purity in accordance with the ÖNORM H 5195 and VDI 2035 standards.

The use of ethylene and propylene glycol in a mixture ratio of 25 - 50% by volume [%] is permitted.

☑ Description

The two port flanged valve is primarily designed to control the flow of circulation water in district heating and HVAC systems, as well as for remote closing of heating pipelines. Circulation medium should be cold, warm and hot water in temperature range from 5°C to 150°C. The valve can be utilized in almost all heating, ventilation and air-conditioning systems and in industrial and technological processes. The valve curve is equal percentage. Regulation ratio (ratio between nominal and minimal flow coefficient) is 30:1. The selection of the two port flanged valve is according to the diagram of kvs values.

For PN16: Valve is closed when the stem is out. Valve is open when the stem is depressed.

For PN25, DN15-65 and DN125-150: Valve is closed when the stem is out. Valve is open when the stem is depressed.

For PN25, DN80-100: Valve is open when the stem is out. Valve is closed when the stem is depressed.

☑ Application examples

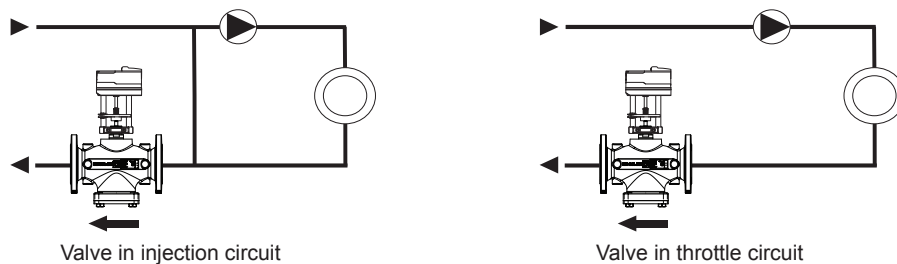

☑ Installation

The valve can be installed in all positions, from horizontal to vertical, except in vertical position with the actuator pointing downwards. The arrow on the valve body must match the direction of fluid flow through the valve. The valves must be installed for the correct application using clean fittings. A HERZ strainer (4111) should be fitted to prevent impurities during operation. Therefore an installation is recommended.

For installation, the local and international standards have to be followed.

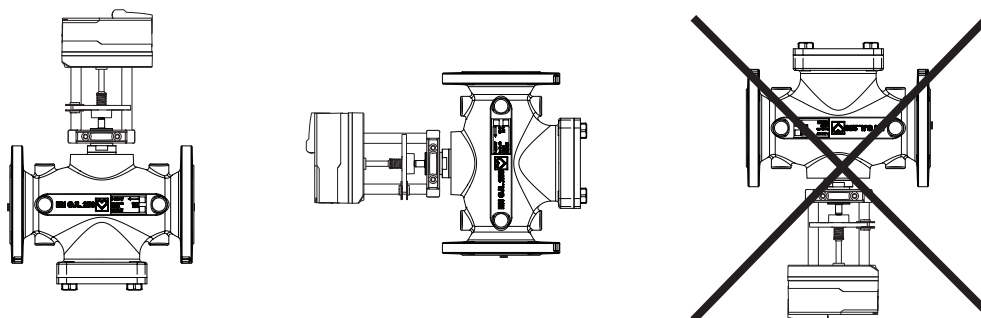

Selection diagram

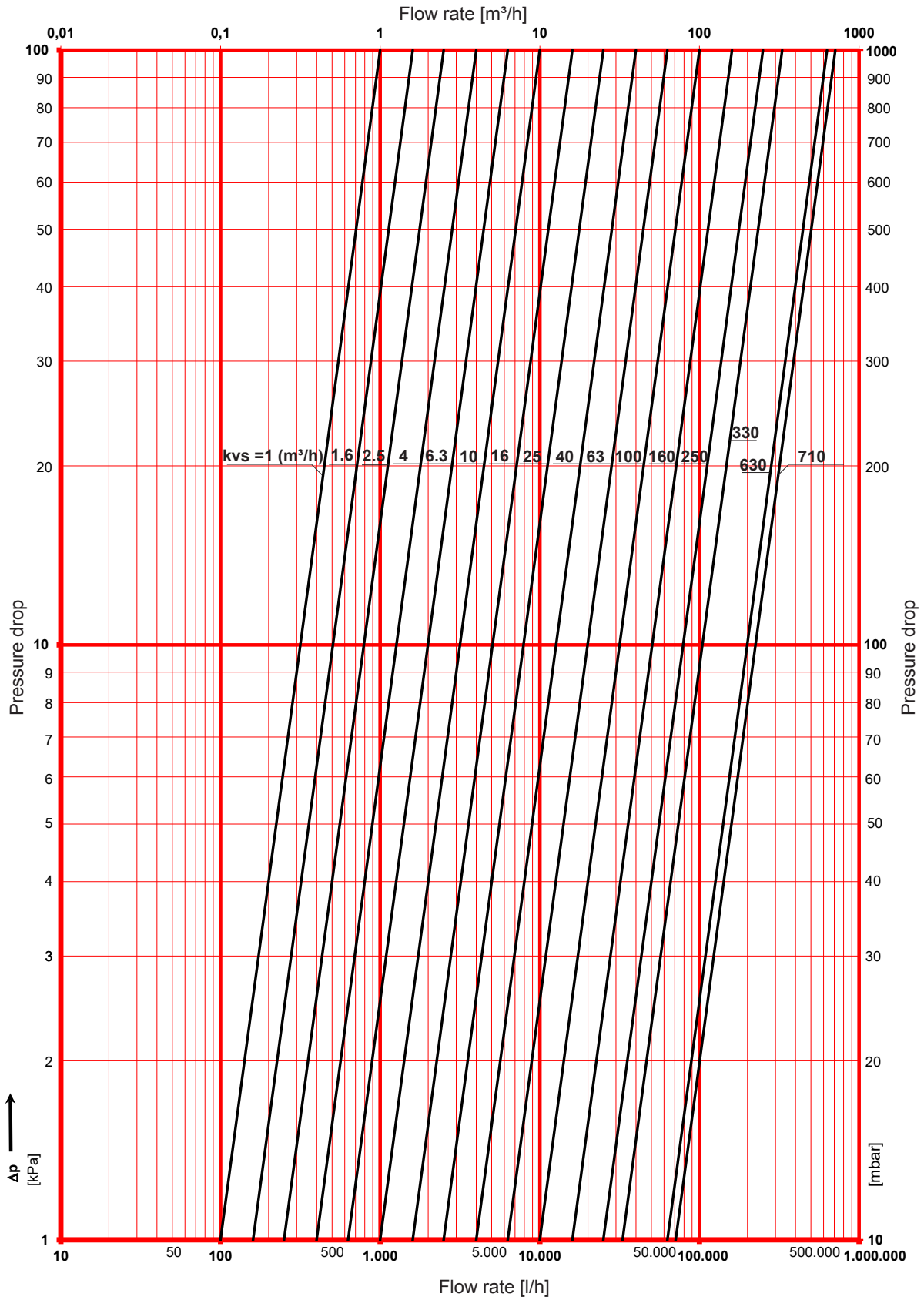

HERZ-Three-Port-Flanged Valve

F 4037 XX

Datasheet „3-Port-Valves, flanged“ PN16

Dimensions in mm

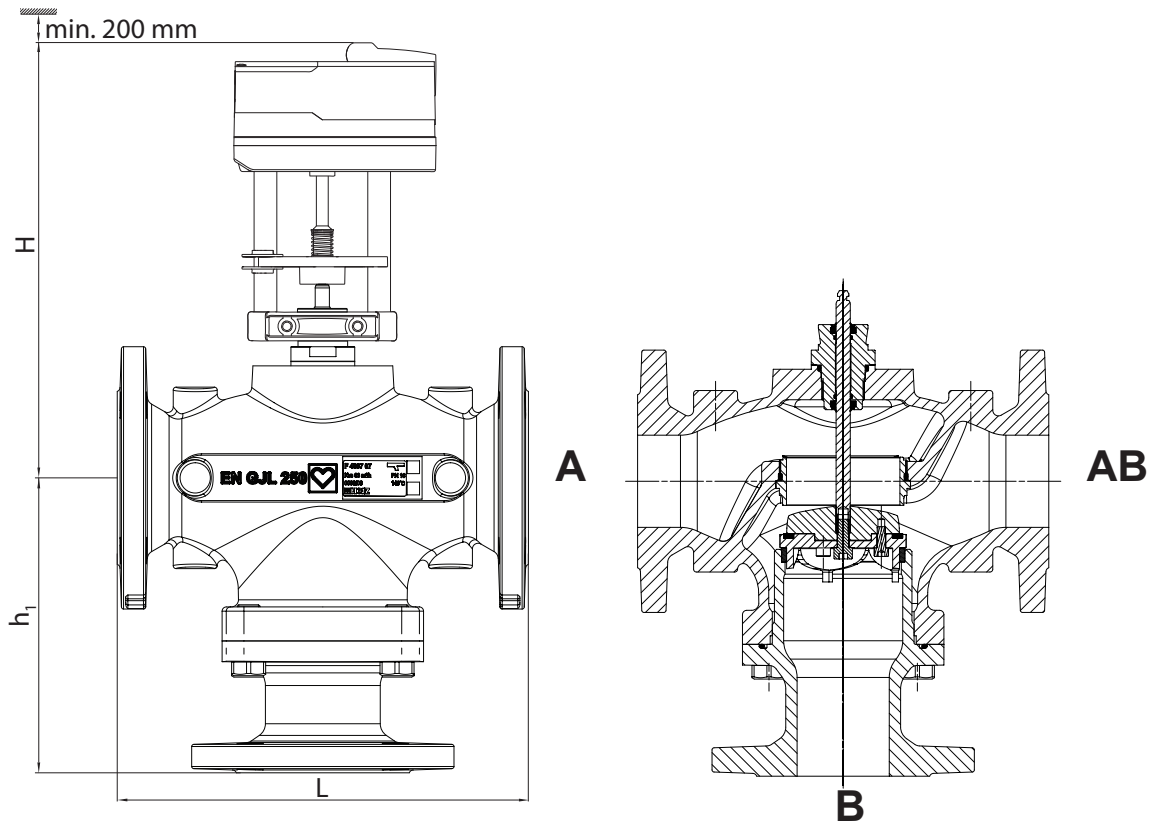

Order Nr.	DN	Stroke [mm]	kvs	D	L	Number of flange bores	d	dk	h1	H	kg
F 4037 01	15	10	1	95	130	4	14	65	110	250	5
F 4037 11	15	10	1,6	95	130			65	110	250	5
F 4037 21	15	10	2,5	95	130			65	110	250	5
F 4037 31	15	14	4	95	130			65	110	250	5
F 4037 03	25	20	6,3	115	160			85	121	255	8
F 4037 13	25	20	10	115	160			85	121	255	8
F 4037 04	32	20	16	140	180	8	19	100	142	305	11,5
F 4037 05	40	20	25	150	200			110	149	315	13
F 4037 16	50	20	40	165	230			125	167	305	16
F 4037 07	65	20	63	185	290			145	208	315	25
F 4037 08	80	20	100	200	310			160	233	350	31
F 4037 09	100	40	160	220	350			180	262	480	46
F 4037 10	125	40	250	250	400	210	268	520	72		
F 4037 41	150	40	330	285	480	23	240	261	525	91	

PN16					Leakage acc. to 12266-1	
Order number	DN	Usage as mixing valve Differential pressure max. [bar]			Direct flow branch	By-pass branch
F 4037 01	15	4,0			≤0.1%kvs	≤0.5%kvs
F 4037 11	15	4,0				
F 4037 21	15	4,0				
F 4037 31	15	4,0				
F 4037 03	25	4,0				
F 4037 13	25	4,0				
F 4037 04	32		4,0		≤0.01%kvs	
F 4037 05	40		4,0			
F 4037 16	50		3,0			
F 4037 07	65		1,5			
F 4037 08	80		1,0			
F 4037 09	100			2,0		
F 4037 10	125			0.9		
F 4037 41	150			0.9		

Selection diagram

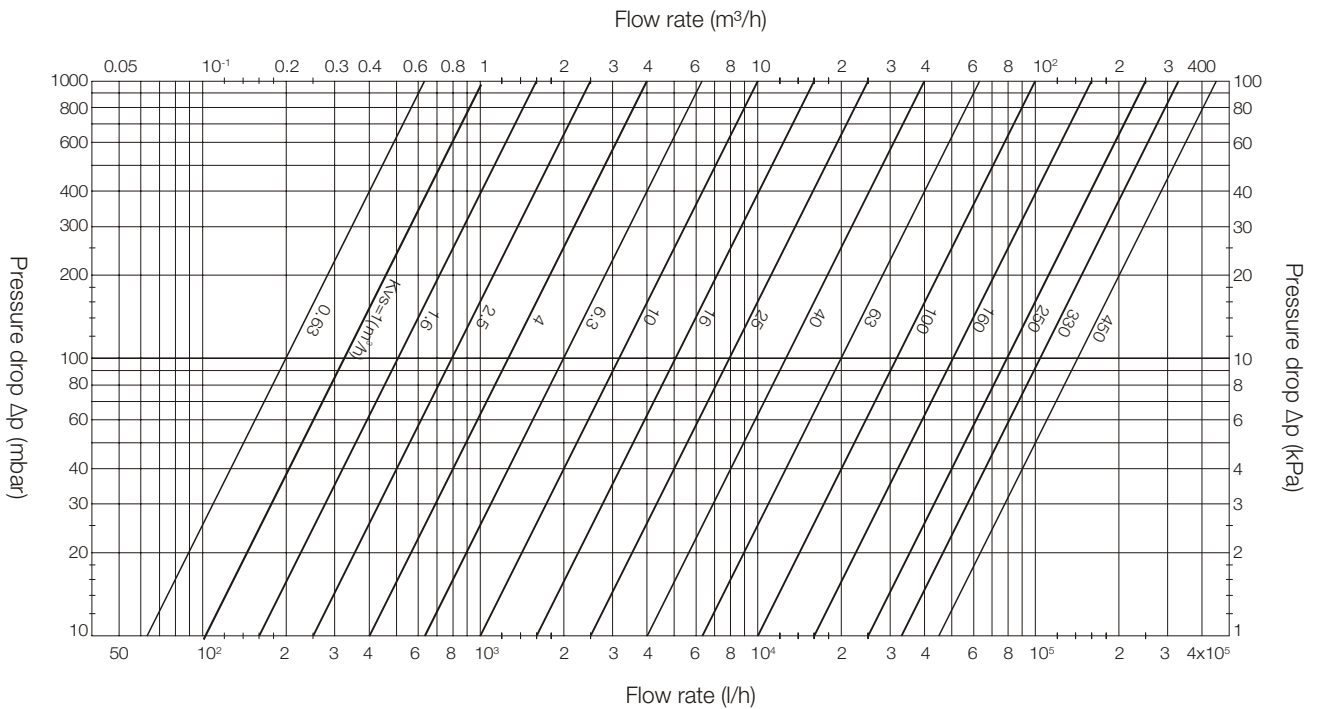

☑ Technical data and material

Max. operating pressure	16 bar (PN 16)
Min. operating temperature	5 °C
Max. operating temperature	150 °C
Valve curves characteristic	equal percentage

Type of connection	Flanges (EN 1092-2)
Valve body material	EN-GJL-250
Sealing element material	70EPDM
Valve seat material	WN1.4021
Valve cones material	WN1.4021/brass
Stem material	WN1.4404

Water purity in accordance with the ÖNORM H 5195 and VDI 2035 standards.

The use of ethylene and propylene glycol in a mixture ratio of 25 - 50% by volume [%] is permitted.

☑ Description

The three port flanged valve is designed to control the flow rate of circulation water in pipelines. Valve stem with cone is moved by acting of electric actuator controlled by microprocessor controller. Circulation medium could be cold, warm and hot water in temperature range from 5°C up to 150°C.

The valve is utilized in almost all heating, ventilation and air-conditioning systems and in industrial and technological processes. The three port flanged valve is used as a mixing valve and in the case when it should change water circulation from one pipeline to another. The valve curve is equal percentage. Regulation ratio (ratio between nominal and minimal flow coefficient) is 30:1. Selection of three-way flanged valve is according to diagram of kvs values.

☑ Installation

The valve can be installed in all positions, from horizontal to vertical, except in vertical position with the actuator pointing downwards. The arrow on the valve body must match the direction of fluid flow through the valve. The valves must be installed for the correct application using clean fittings. A HERZ strainer (4111) should be fitted to prevent impurities during operation. Therefore an installation is recommended. For installation, the local and international standards have to be followed.

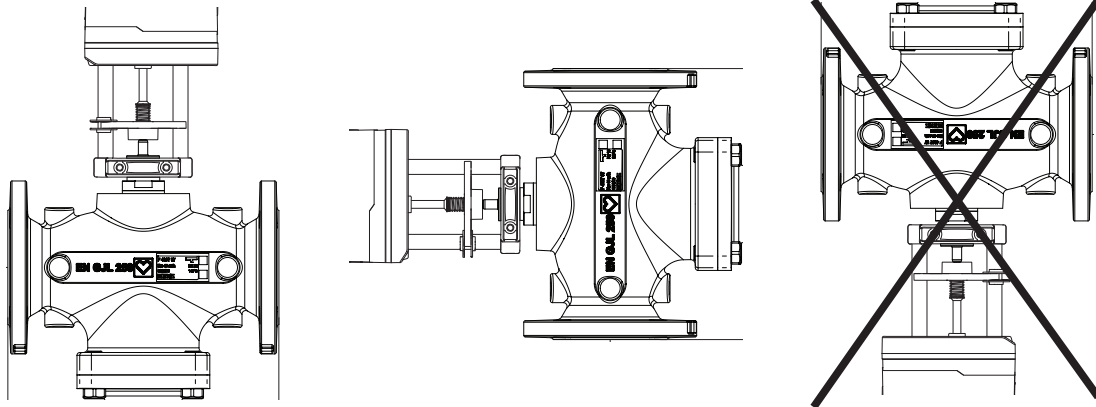

☑ Application examples

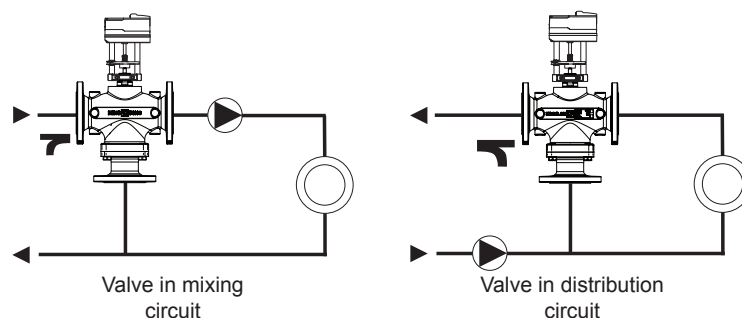

Selection matrix

In order to select a right actuator please refer to the selection matrix.

Order number (actuator)			F 7712 90	F 7712 95	F 7712 81	F 7712 91	F 7712 96	F 7712 82	1 7712 32	F 7712 92	F 7712 98	F 7712 84
Actuator type			24 V, continuous	24 V, 2-3 Point	230 V, 2, 3 Point	24 V, continuous	24 V, 2-3 Point	230 V, 2, 3 Point	24 V, 2-3 Point	24 V, continuous	24 V, 2-3 Point	230 V, 2-3 Point
Order number	DN	T °C	500 N, 15 mm	500 N, 15 mm	500 N, 15 mm	1000 N, 20 mm	1000 N, 20 mm	1000 N, 20 mm	2500 N, 40 mm	2500 N, 40 mm	2500 N, 40 mm	2500 N, 40 mm
F 4035 01	15	150	direct assembly	direct assembly	direct assembly							
F 4035 40												
F 4035 11	15	150	direct assembly	direct assembly	direct assembly							
F 4035 51												
F 4035 11	15	150	direct assembly	direct assembly	direct assembly							
F 4035 61												
F 4035 31	15	150	direct assembly	direct assembly	direct assembly							
F 4035 71												
F 4035 03	25	150	direct assembly	direct assembly	direct assembly							
F 4035 43												
F 4035 13	25	150	direct assembly	direct assembly	direct assembly							
F 4035 53												
F 4035 04	32	150				direct assembly	direct assembly	direct assembly				
F 4035 44												
F 4035 05	40	150				direct assembly	direct assembly	direct assembly				
F 4035 45												
F 4035 16	50	150				direct assembly	direct assembly	direct assembly				
F 4035 56												
F 4035 07	65	150				direct assembly	direct assembly	direct assembly				
F 4035 47										direct assembly	direct assembly	direct assembly
F 4035 08	80	150				direct assembly	direct assembly	direct assembly				
F 4035 48										direct assembly	direct assembly	direct assembly
F 4035 09	100	150							direct assembly	direct assembly	direct assembly	direct assembly
F 4035 49												
F 4035 10	125	150							direct assembly	direct assembly	direct assembly	direct assembly
F 4035 50												
F 4035 41	150	150							direct assembly	direct assembly	direct assembly	direct assembly
F 4035 52												
F 4035 42	200	150							direct assembly	direct assembly	direct assembly	direct assembly
F 4035 54	250	150							direct assembly	direct assembly	direct assembly	direct assembly
F 4037 01	15	150										
F 4037 11	15	150	direct assembly	direct assembly	direct assembly							
F 4037 21	15	150										
F 4037 31	15	150	direct assembly	direct assembly	direct assembly							
F 4037 03	25	150	direct assembly	direct assembly	direct assembly							
F 4037 13	25	150	direct assembly	direct assembly	direct assembly							
F 4037 04	32	150				direct assembly	direct assembly	direct assembly				
F 4037 05	40	150				direct assembly	direct assembly	direct assembly				
F 4037 16	50	150				direct assembly	direct assembly	direct assembly				
F 4037 07	65	150				direct assembly	direct assembly	direct assembly				
F 4037 08	80	150				direct assembly	direct assembly	direct assembly				
F 4037 09	100	150							direct assembly	direct assembly	direct assembly	direct assembly
F 4037 10	125	150							direct assembly	direct assembly	direct assembly	direct assembly
F 4037 41	150	150							direct assembly	direct assembly	direct assembly	direct assembly